

pro clima®

Intelligent Airtight
and Windtight
building systems

product portfolio



ecological
BUILDING SYSTEMS



Courtesy Green Building Store

Why pro clima?

Our pro clima product portfolio shows key details and products required to build airtight and windtight buildings, helping to reduce the carbon footprint of our built environment and making energy savings, leading to comfortable, healthy, low energy buildings.

By choosing the pro clima range, you can be confident that you are implementing a robust, durable and energy efficient airtight and windtight design strategy for your build.

Key attributes to the pro clima range include:

- BBA  NSAI  and  Approved, (refer to individual product pages for relevant approvals)
- INTELLO PLUS is the most advanced reinforced Intelligent airtight and vapour control membrane on the market
- pro clima tapes and glues are solid acrylic and so provide a permanent airtight seal even in humid climate conditions like Ireland and the UK
- Sentinel Haus  approved to ensure healthy installation and living space
- Helps prevent mould and structural degradation and ensure a healthy living environment
- The pro clima tapes, TESCON VANA, No. 1 and UNITAPE are currently the only tape yet to pass the Kassel Institute accelerated aging test for 100 years performance
- In an independent consumer watchdog publication in Germany 8 leading airtightness system brands were tested. pro clima was confirmed as the best and most reliable system on the market



Courtesy Bere Architects



pro clima were founded in 1981 and are now active in over 20 countries. pro clima products are manufactured according to the highest quality standards of Europe and solely distributed in Ireland and the UK by Ecological Building Systems, working with a network of trained stockists.



Courtesy Miles Sampson Sustainable Architecture



Courtesy Archtype



Courtesy JPW Construction



Courtesy Green Building Site



Courtesy Green Building Site

pro clima Intelligent Vapour Control/Airtight Membranes

INTERNAL AIRTIGHT PRODUCTS



INTELLO PLUS
Intelligent vapour check and airtight membrane

TESCON PROFIL
Multi-purpose flexible corner sealing tape for windows, doors and corner joints

ORCON F
Multi-purpose adhesive

CONTEGA SOLIDO SL
Vapour resistant masonry plaster sealing tape

CONTEGA SOLIDO SL
Vapour resistant masonry plaster sealing tape

TESCON No.1/VANA
Multi-purpose flexible adhesive tape for airtight and windtight sealing

ROFLEX
Airtightness grommet for pipework

Other Internal Airtight Products

DB+
Cellulose intelligent vapour check and airtight membrane

DA
Weather resistant airtight vapour check

DA-S
Airtight vapour check sealing strip

UNI TAPE
Universal paper based adhesive tape for permanent, airtight and secure bonding

EXTOSEAL FINOC
Butyl watertight capillary break tape

EXTOSEAL MAGOV
Butyl tape for airtight connections around service penetrations

ORCON LINE
Multi purpose flexible joint adhesive on a roll

KAFLEX
Airtightness grommet for cables and small pipes

INSTAABOX
Airtight installation of service boxes

EXTERNAL WINDTIGHT ROOF PRODUCTS

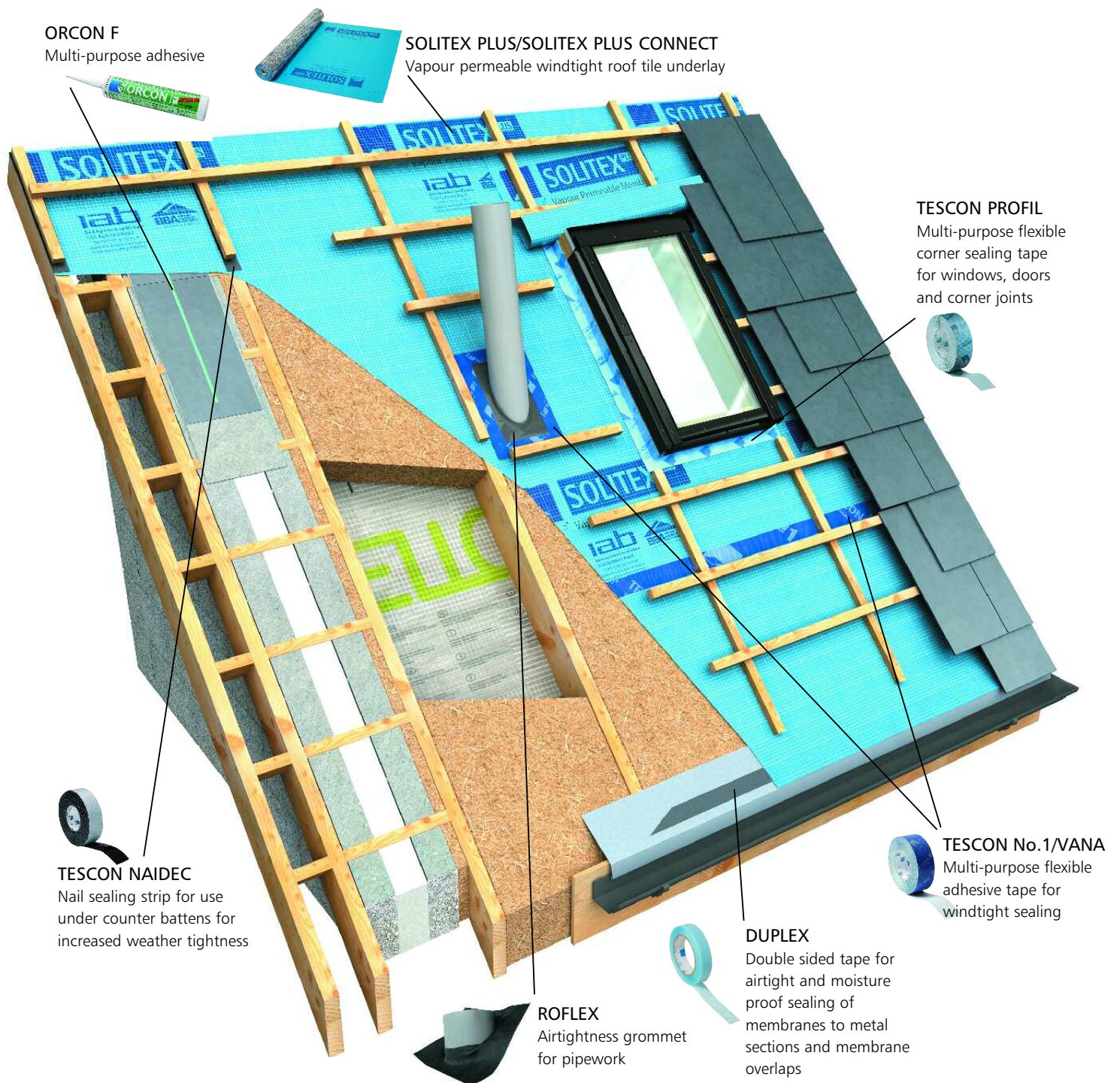

Other External Windtight Roof Products

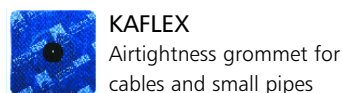
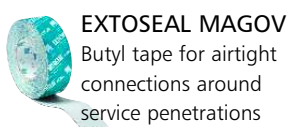
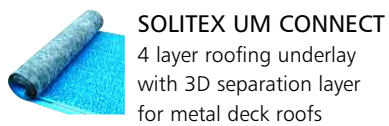
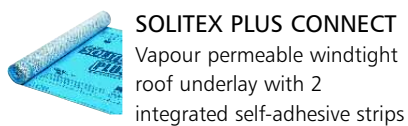

EXTERNAL WINDTIGHT WALL PRODUCTS

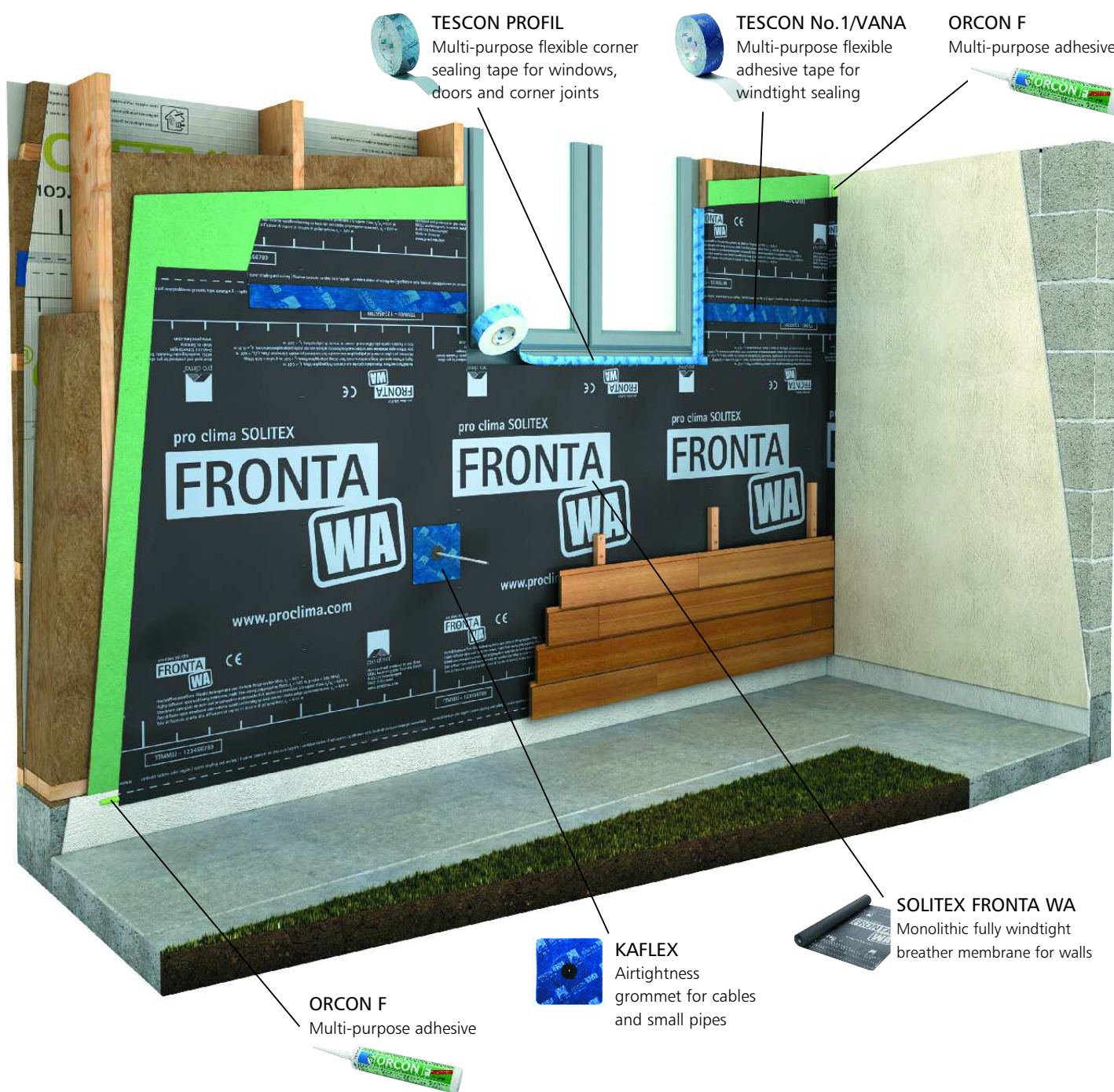

TESCON PROFIL
Multi-purpose flexible corner sealing tape for windows, doors and corner joints

TESCON No.1/VANA
Multi-purpose flexible adhesive tape for windtight sealing

ORCON F
Multi-purpose adhesive

pro clima SOLITEX
FRONTA WA

pro clima SOLITEX
FRONTA WA

pro clima SOLITEX
FRONTA WA

www.proclima.com

www.proclima.com

SOLITEX FRONTA WA
Monolithic fully windtight breather membrane for walls

KAFLEX
Airtightness grommet for cables and small pipes

ORCON F
Multi-purpose adhesive

Other External Windtight Wall Products

SOLITEX FRONTA QUATTRO
Monolithic windtight membrane suitable for use on open jointed facades

SOLITEX HUMIDA
External wall lining membrane for use behind ventilated brick and stone walls in conjunction with soft wood fibreboards

TESCON INVIS
A black tape for use with Solitex Fronta Quattro for concealing taped junctions

EXTOSEAL ENCORS
Butyl flashings for window sills and door thresholds

EXTOSEAL FINOC
Butyl watertight capillary break tape

CONTEGA SOLIDO EXO
Diffusion open plaster sealing tape for windows

CONTEGA FIDEN EXO
Pre-compressed joint sealing tape for exterior use

Summary of products and index

General Information

Airtightness Questions	Page 2-5
Airtightness Installation Guide	19-20
PASSIVE EcoWall	25
Ecological Building Systems Ltd Information and Contact Details	28



Product	Type	Interior	Exterior	
Membranes - Intelligent airtight vapour checks & windtight vapour permeable membranes				
INTELLO PLUS	Intelligent vapour check and airtight membrane	✓		6
DB+	Cellulose Intelligent vapour check and airtight membrane	✓		7
DA	Weather resistant airtight vapour check membrane	✓	✓	8
DA-S	Airtight vapour check sealing strip	✓		8
SOLITEX PLUS	Vapour permeable windtight roof tile underlay		✓	21-22
SOLITEX PLUS CONNECT	As above with 2 integrated self-adhesive strips		✓	23
SOLITEX UM CONNECT	Vapour permeable roof lining beneath metal sheet roofing		✓	23
SOLITEX FRONTA WA	Monolithic fully windtight breather membrane for walls		✓	24
SOLITEX FRONTA QUATTRO	UV stable monolithic fully windtight breather membranes for walls		✓	24
SOLITEX FRONTA HUMIDA	3-ply slightly diffusion resistant wall membrane for ventilated masonry walls		✓	25

Tapes and Adhesives

ECO COLL	A natural glue adhesive for the airtight sealing of DB+	✓		7
ORCON F	Multi-purpose adhesive	✓	✓	9
ORCON Line	Multi-purpose flexible adhesive on a roll	✓		9
UNI TAPE	Universal paper based adhesive tape for permanent, airtight and secure bonding	✓		10
TESCON No. 1	Multi-purpose flexible adhesive tape for airtight sealing	✓	✓	11
TESCON VANA/PATCH	Tensile multi-purpose adhesive tape for airtight sealing	✓	✓	11
TESCON PROFIL	Multi-purpose flexible corner tape for windows, doors and corner joints	✓	✓	12
TESCON INVIS	Black multi-purpose sealing tape	✓	✓	12
TESCON NAIDEC	Double sided butyl rubber nail sealing tape		✓	13
TESCON Primer RP	Priming coat suitable for wood fibreboards	✓	✓	13
CONTEGA SOLIDO SL	Vapour resistant window plaster sealing tape	✓		14
CONTEGA SOLIDO EXO	Diffusion open plaster sealing tape for windows		✓	14
CONTEGA FIDEN EXO	Pre-compressed joint sealing tape		✓	15
EXTOSEAL MAGOV	Highly flexible butyl tape for making airtight connections	✓	✓	15
EXTOSEAL ENCORS	Water bearing butyl connection tape		✓	16
EXTOSEAL FINOC	Multi-purpose moisture tight butyl tape	✓	✓	16

Pipe and Cable Grommets

ROFLEX	Airtightness grommet for pipework	✓	✓	17
KAFLEX	Airtightness grommet for cables	✓	✓	17
INSTAABOX	Airtight installation of service boxes	✓		18

Accessories

WINCON TEST UNIT	Airtightness quality control unit			18
OPTIME AIRTIGHT DOWNLIGHT PROTECTOR	Sealing system for down lights	✓		26
WELLHOFER	Certified pre-insulated airtight attic hatch	✓		27

What is airtightness?

Airtightness is the control of air leakage, i.e., the elimination of unwanted draughts through the external fabric of the building envelope. This may be achieved by the correct and proper installation of a vapour check or vapour barrier. Consequently condensation, mould, rot, damp and structural damage are also eliminated. This ensures a more viable structure, an insulation layer that can perform properly as it is now protected against penetrating moisture reducing the amount of energy-in-use in the building and CO2 emissions. While ventilation is intended, air leakage is not. **It is desirable and necessary to have controlled ventilation for healthy comfortable buildings.**

→ - Potential air leakage paths → - Intended ventilation/openings



Figure 1 A draughty leaky house



Figure 2 A comfortable well sealed, well ventilated house
The key is to **build tight and ventilate right.**

Why build for airtightness?

Sustainable design and construction to achieve low energy, PassivHaus and zero carbon homes are now at the forefront of the building and planning process. Codes and standards are in place which aim to reduce carbon emissions and create homes that are healthier and more sustainable.

The only way to achieve PassivHaus, low carbon and nearly zero energy building is to ensure a high level of airtightness is attained.

That means designing and installing a continuous seal around the internal fabric of the external envelope to eliminate unwanted draughts. Once the airtight vapour check is in place and sealed with flexible and durable tapes, seals and glues, it ensures that the insulation functions to its optimum performance, saving energy and drastically reducing carbon emissions for the lifetime of the building.

The airtight vapour check also ensures that interstitial condensation risk is minimised, ensuring no structural damage from moisture, mould, rot and damp.

What is an 'Intelligent' Airtight System?

pro clima are pioneers and market leaders of an 'Intelligent' airtight system. This differs greatly from conventional vapour barriers and vapour checks.

The technology used in pro clima membranes, **INTELLO PLUS** and **DB+** ensures membranes may become more vapour 'diffusion open' when required. This means that they have the ability to alter their vapour diffusion resistance depending on the average relative humidity surrounding the vapour check. See Figure 3.

In winter the membrane remains diffusion tight (see Figure 4) and will resist the diffusion of vapour from the internal fabric of the building into the insulated layer. However, in summer (see Figure 5) pro clima's membranes, **INTELLO PLUS** and **DB+**, may become more vapour open. This allows any moisture which may be trapped in the insulated fabric of the building to back dry to the inside of the house, something a conventional vapour barrier/check cannot do. This ensures a very high level of safety from structural damage due to moisture accumulation over seasonal periods. An Intelligent membrane facilitates significantly more drying compared to a vapour barrier/check. The membrane always remains airtight.

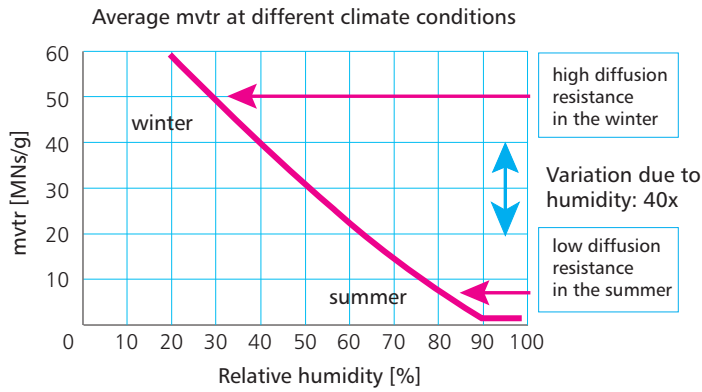

Figure 3
INTELLO PLUS humidity variable vapour diffusion resistance graph

Figure 4
Winter

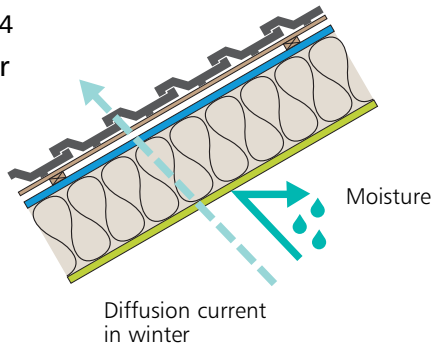
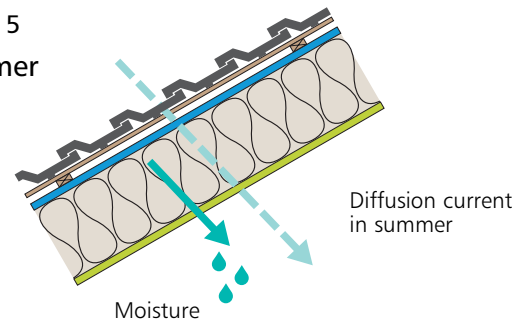

Figure 5
Summer



Why would moisture accumulate within building elements?

Unanticipated moisture may be present in buildings; perhaps as a result of extremely adverse conditions during the building stage (e.g. the timber/insulation gets damp) due to flanking, diffusion directly through the membrane or air leakage (e.g., convection). Using an 'Intelligent' pro clima vapour check ensures that this moisture can dry as quickly as possible due to its unique diffusion properties. Conventional vapour barriers remain vapour tight under all conditions which may lead to damaging moisture build up. The pro clima system offers superior protection against even extreme unforeseen circumstances.

Research shows that under normal winter conditions around 0.5g per sqm per day of moisture is able to penetrate a gap free vapour check/barrier (mvtr 150 MNs/g) by diffusion. See Figure 6 with a 1mm tear over a 1 square metre area in the vapour check/barrier as much of 800g of moisture can be transferred into the structure per square metre per day by air leakage (convection) – a reduction in performance by 1,600 times!

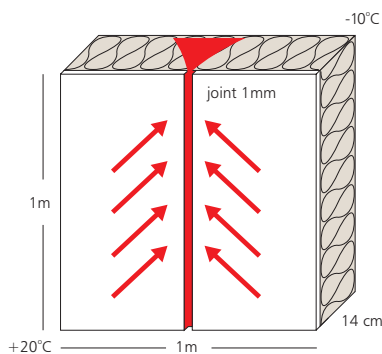

Measurements were taken at an air temperature difference of +20°C (68°F) indoors and -10°C (14°F) outdoors, a pressure difference of 20 Pa (equivalent to wind force 2-3) using conventional, fibrous insulating material.

Such a small tear can reduce the diffusion resistance by a factor of 1600.

Measurement carried out by: *Institut für Bauphysik, Stuttgart.*

Figure 6



Does this mean a 'Healthier House'?

It is estimated that we spend up to 90% of our life in buildings. Therefore indoor air quality and anything lending itself to reducing risks associated with mould growth is desirable. Mould, rot and fungus may occur as a result of excessive moisture penetration to the fabric of the building. The pro clima system eliminates any potential for this damage due to its ability to allow drying to occur, resulting in a much higher level of air quality in the house and creating a far healthier home and durable building.

Won't an airtight house be a stuffy house?

All buildings have to be ventilated for health and comfort and that's exactly the same for an airtight building. A suitable ventilation system has to be planned in the design process for every building. The ventilation system will vary depending upon the levels of airtightness to be achieved and the home owners' requirements, from passive ventilation to mechanical ventilation systems for zero carbon and PassivHaus design. **While ventilation is intended, air leakage is not! The key is to control ventilation and minimise leaks.** Of course one can open a window in an airtight house, however, in an airtight house, when the window is closed, no air leakage occurs around the window frame or sill. **The key is to Build Tight - Ventilate Right.**

Is it difficult and costly to install for airtightness?

Achieving an airtight seal isn't difficult, but it does need to be designed and planned, and attention to detail given on site - it's all about thinking two steps ahead in order to ensure overlaps and joints are effectively sealed. **Take a look at our installation guide on pages 19-20 of the brochure for more information and view our airtight installation videos on our website www.ecologicalbuildingsystems.com**

Short cuts and poor workmanship result in air leakage which if detected at the Blower Door testing stage are difficult to rectify. An 'out of sight, out of mind' attitude leads to leaky building. Forethought and monitoring with intermediate assessments through the build process by the use of the pro clima Wincon quality control unit to detect air leakage, minimises and mitigates the need for any costly remediation work. We estimate that the material cost of installing the pro clima airtight system is as little as 0.5% of the total build cost on an average build. The primary cost is related to labour, hence forethought and good design can significantly reduce costs. And then think of the energy saved for the life of the building and you also have a healthy building

Will installing for airtightness save energy and reduce heating bills?

Research shows that we can lose as much as half of all the energy used to heat our buildings through unwanted draughts, inefficient and poor ventilation. We now generally insulate new houses very well but the proportion of energy lost to draughts has increased and in some cases around half of all heat losses are due to air leakage across the building fabric. In Ireland and the UK we are not exposed to extremes in low temperatures, however our climate is exposed to high wind pressure, particularly in coastal regions.

If a vapour check has as little as a 1mm tear within a square metre area, the U value can reduce by a factor of 4.8 (See Figure 7.!) This means that the calculated U value is not achieved if the structure is not airtight and hence you need a lot more energy to heat the house. Airtightness does not generally increase U values, but ensures the calculated U value is achieved.

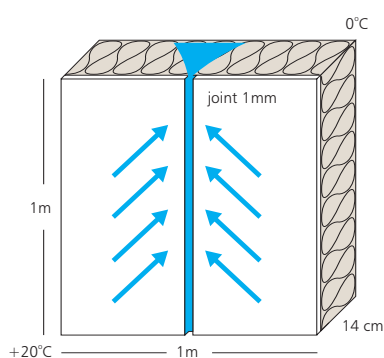

Measurements were taken at an air temperature difference of +20°C (68°F) indoors and -10°C (14°F) outdoors, a pressure difference of 20 Pa (equivalent to wind force 2-3) using conventional, fibrous insulating material.

U-value with airtight vapour barrier = 0.30 W/m²K

U-value with 1mm gap in vapour barrier = 1.44 W/m²K

A gap as small as 1mm in the vapour barrier can reduce the U-Value by a factor of 4.8

Measurement carried out by: Institut für Bauphysik, Stuttgart.

Figure 7

An airtightness layer protecting the insulation is just like wearing a wind shield jacket over our woolly jumper, it ensures that the insulation works to its full potential see Figure 8.

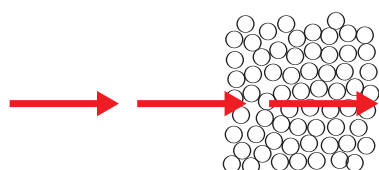

If air moves within insulation it substantially effects the thermal performance.

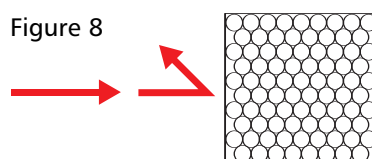

Now it is protected the insulation works to its optimum thermal performance

How do I measure airtightness and what level of airtightness should I aim to achieve?

The most commonly used unit of measurement for airtightness in Ireland and the UK is referred to as the *air permeability* of a building or Q50.

To measure air permeability a pressure differential is induced onto a building using a large fan called a Blower Door. An airtightness measurement usually involves a combination of depressurising and pressurising a building to a pressure difference of 50 Pascal's (50Pa) which is equivalent to a wind speed of about 20 miles per hour on every side of the building envelope at once, by no means an extreme pressure. Once the pressure differential reaches 50 Pa, air leakage may easily be located in the external envelope and an accurate measurement of the air permeability of the external envelope of the building is taken. The air permeability of a building at a pressure differential of 50Pa is referred to as the Q50 of a building and is measured in m³/hr (of airflow) per m² (of total external envelope area).

Please refer to the latest edition of the building regulations for further information about the maximum permissible air permeability rates based on your jurisdiction. For your guidance a Q50 of less than 10m³/hr/m² refers to an air permeability of less than 10m³ of air per hour per m² of the external envelope of a building when the building is exposed to a pressure differential by depressurisation and/or pressurisation of 50 Pa. This literally means that when we exclude ventilation and design openings, and exert a pressure difference of 50Pa on the external envelope of the building 10m³ of air per hour passes through every square metre of the external envelope.

According to the Airtightness Testing and Measurement Association (ATTMA), for airtightness best practice, buildings which are mechanically or naturally ventilated should achieve an air permeability of less than 3m³/hr/m², this is quite a high level of airtightness. However the highest level of airtightness required in buildings can be as low as less than 0.6 air changes per hour at 50Pa, which is required in the PassivHaus Standard, which are typically mechanically ventilated.

As airtightness is a central part to low energy construction, it must be a priority to achieve best practice airtightness when we build, extend or renovate our buildings.

Why is windtightness important?

To achieve maximum thermal efficiency the insulation must be completely sealed on both sides. Figure 9 shows an insulated rafter space with a windtight sealed vapour diffusion open membrane (e.g. a windtight layer) on the outside and an airtight layer (e.g. a sealed Intelligent vapour check) on the inside. The insulation is protected against the elements on the outside by the SOLITEX PLUS membrane and against the penetration of indoor air and vapour on the inside by the airtight seal (e.g. vapour check) in this case INTELLO PLUS. The construction is now windtight externally and airtight internally, similar to a wind breaker over a woolly jumper – perfect!

That's why it makes environmental and economical sense to seal tight and ventilate right!

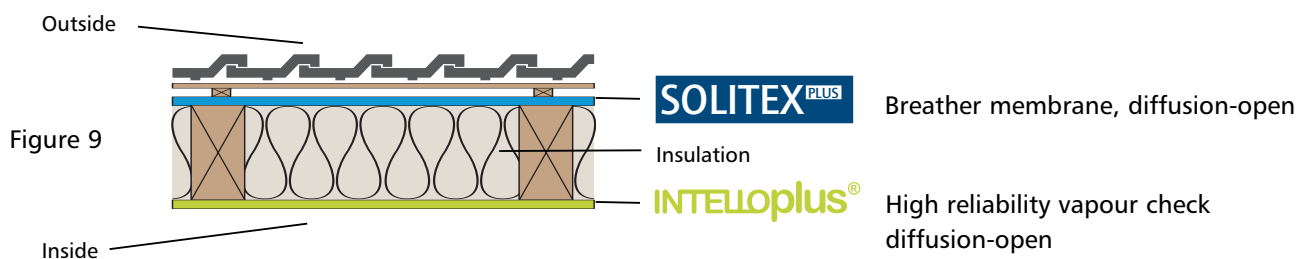

How can I get more advice on how to achieve an airtight building?

For installers there are various installation demonstration videos of the pro clima Intelligent airtight system on our website www.ecologicalbuildingsystems.com and we also provide a DVD on installing for airtightness.

For architects we have specification details on pro clima prepared by:



We at Ecological, along with your pro clima stockist are always available to help guide you through design detailing, products and advice on installation.

pro clima INTELLO®PLUS Intelligent vapour check features humidity-variable diffusion resistance. It gives maximum protection to thermal insulation where moisture entry may have occurred. This may be through leaks, damp building materials or diffusion through adjoining structural surfaces. INTELLO PLUS possesses the world's best and most effective variable diffusion resistance.

This ensures optimum protection for all fibrous insulating materials in all constructions, whether they are vapour diffusion permeable or vapour diffusion resistant externally such as pitched roofs with bitumen sheeting or metal sheet roofing, flat roofs and walls with a diffusion resistant exterior cladding.

Features

- Provides optimum protection for all thermal insulation systems in roofs, walls and floors.
- Offers high diffusion tightness in winter and maximum diffusion openness in summer.
- In winter, its high diffusion resistance provides ideal protection for the building's structure against condensation.
- In summer, its low diffusion resistance facilitates rapid drying.
- It is translucent, easy to install, fully recyclable.
- It offers the ideal solution to structures that are difficult to protect against condensation e.g. flat roofs, flexible metal sheeting, etc.
- INTELLO PLUS provides lasting protection from mould growth, which protects the health of the occupants and structural durability.
- Meets with the durability requirements of EN 13984.
- Has a very high nail tear resistance due to reinforcing layer.

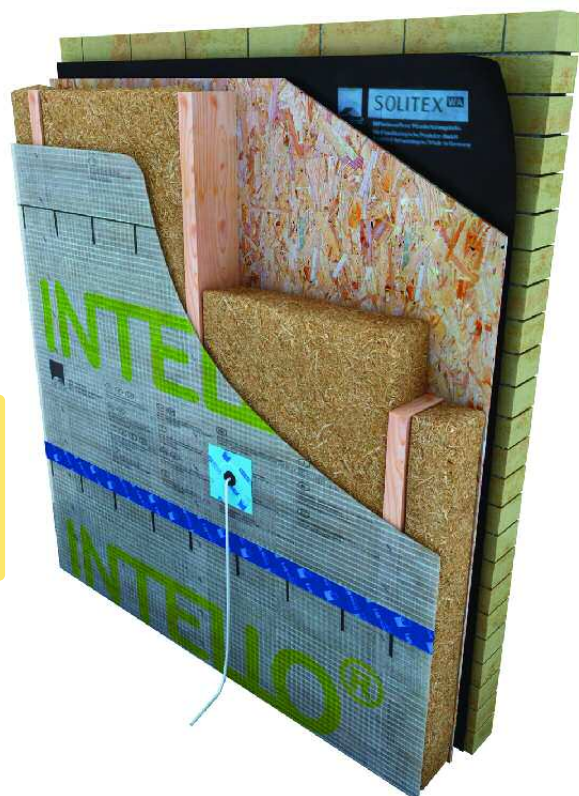

For sealing overlaps we recommend:

- TESCON VANA or pg 11
- TESCON No.1 or pg 11
- UNI TAPE pg 10

► **TIP** In roof refurbishment pro clima supply the airtightness vapour check DASATOP, contact us for further details.





pro clima INTELLO PLUS

Intelligent vapour check and airtight membrane



Technical Details

Material/s:	Membrane: polyethylene copolymer; Fleece and reinforcement layer: polypropylene
Vapour resistance: (humidity variable)	< 1.28 MNs/g > 51 MNs/g
Fire Rating:	E
Temperature Resistance:	-40°C to 80°C
3rd party accreditation:	  
Colour:	White
Roll Width:	1.5 metres and 3 metres
Roll Length:	20 & 50 metres
Usage:	Interior only
Service Life:	100 years

The principal raw material used to produce pro clima DB+ is recycled paper which is strengthened with a reinforcement layer. DB+ is an environmentally friendly option for the sustainable house builder.

Features

- pro clima DB+ is an internal paper based humidity variable INTELLIGENT airtight vapour check which possesses effective variable diffusion resistance properties.
- It is manufactured from cellulose fibre, reinforced for additional strength and treated with natural salts against fire.
- pro clima DB+ cellulose humidity variable vapour check provides a consistent internal airtight seal for the construction, while reducing the risk of interstitial condensation in both summer and winter conditions. In summer conditions pro clima DB+ allows more vapour diffusion, therefore structural components can rapidly dry out. In winter conditions it permits less vapour diffusion, ensuring the building remains protected against vapour penetration, hence protecting the building fabric from harmful moisture.
- In non-breathing structures (i.e. those with vapour impermeable materials installed externally), any moisture that penetrates the insulation may become trapped and immediately begin to degrade its performance. DB+ eliminates this risk by allowing any trapped moisture to evaporate on a seasonal basis, due to its humidity variable vapour resistance.
- pro clima DB+ Meets with the durability requirements of EN 13984.

Technical Details

Material/s:	Recycled paper, paper, halogen and plasticiser-free PE film
Vapour diffusion:	< 3.06 MNs/g to > 20.4 MNs/g
Fire Rating:	E
Temperature Resistance:	-40°C to 40°C
3rd party accreditation:	 
Colour:	Blue
Roll Width:	1.35 metres
Roll Length:	50 metres
Recycled content to ISO 14021:	Recycled paper
Usage:	Interior only



pro clima DB+

Intelligent vapour check and airtight membrane

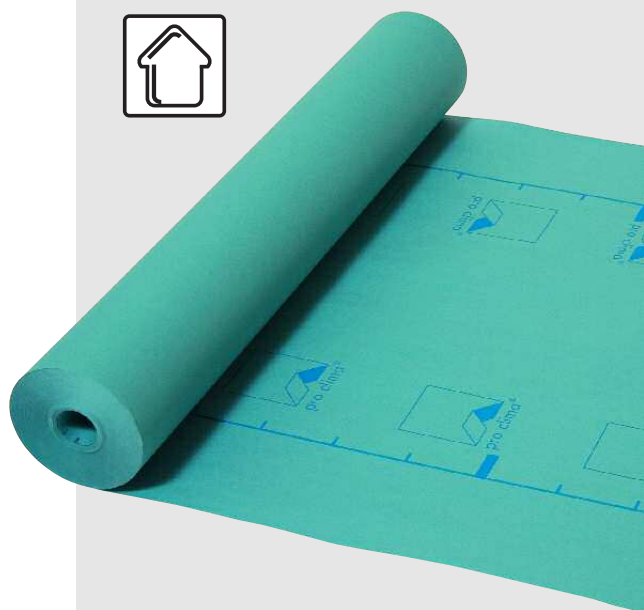

For overlaps and sealing solutions we recommend:

UNI TAPE	pg 10
ECO COLL or	pg 7
ORCON F	pg 9

pro clima ECO COLL



A natural glue adhesive only to be used in conjunction with DB+

www.ecologicalbuildingsystems.com



pro clima DA is an airtight vapour check. It can be used as a cost effective solution independently or in conjunction with OSB internally to ensure a continuous airtight and vapour control layer is attained. DA can be used as an external airtightness and vapour control layer on roofs and walls. The membrane protects the construction from moisture during the building phase and then acts as your vapour control and airtightness layer. It is suitable for all constructions which are externally diffusion open.

Features

- Acts as a vapour check and airtightness layer simultaneously.
- Provides protection against the elements during the construction phase on roof retrofits.
- Water-resistant and waterproof.

Technical Details

Material/s: PP fleece
 Vapour Diffusion: 11.5 MNs/g
 Temperature Resistance: -40°C to 100°C
 Fire Rating: E

Colour: Green
 Roll Width: 1.5 metres
 Roll Length: 50 metres
 Usage: Interior and Exterior
 3rd party accreditation: 

► **TIP** DA ensures consistent airtightness & vapour control on the inside of OSB.

For sealing overlaps we recommend:
TESCON VANA/No.1 pg 11



DA-S is an airtight sealing strip for airtight bonds between building elements such as wall to floor junctions.

Features

- For airtight connections between roof slopes and wall to floor connections.
- pro clima DA-S strips are glued to building substrates to maintain airtightness continuity at critical junctions, for example floor connections at concrete ceilings, on plywood, chipboard sheets or even for sealing large gaps at window reveals in accordance with regulations by DIN 4108, SIA 180 and ÖNorm B8110-2.
- More resistant to site conditions compared to conventional vapour checks.
- It also functions as a vapour check and airtight sealing layer and is generally applied on the interior side of the insulation layer.

Technical Details

Material/s: 2 layered polypropylene fleece, polypropylene film (halogen free)
 Temperature Resistance: -40°C to 90°C
 Fire Rating: E
 Roll Width: 21 cms
 Roll Length: 100 metres
 Service Life: 60 years +
 Usage: Interior only

3rd party accreditation: Meets DIN EN 13984
 

► **TIP** The double dispensing adaptor allows installers to apply 2 beads of ORCON F to concrete or OSB boards in one sequence.

For sealing solutions we recommend:
ORCON F pg 9 **TESCON VANA/No.1** pg 11

pro clima DA

Airtight Vapour Check

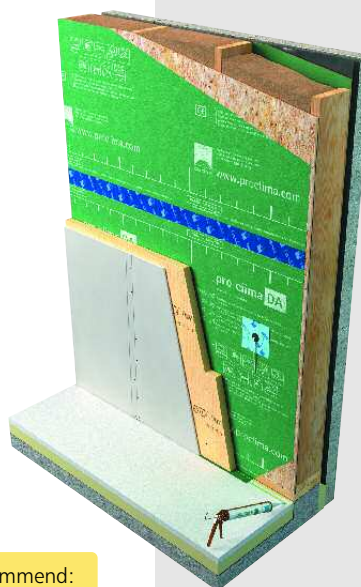

pro clima DA-S

Vapour check and airtight sealing strip manufactured from PP with a robust Polypropylene Protection Fleece



ORCON F has exceptionally high adhesion properties while also being elastic. Its outstanding adhesion to building materials gives the joint the necessary safety and longevity. It is suitable for bonding all of the pro clima vapour checks and air-proofing membranes, PE/PA/PP and aluminium foils to other building materials regardless of smooth, rough or smooth stony surface. Unstable or crumbling surfaces either need to be removed or sanded and stabilised using Tescon Primer RP.

Features

► **TIP** An easy press extrusion gun is available with 600ml refill tubes. Please contact for further details.

- High strength on building material substrates.
- Airtight bonding in accordance with DIN 4108-7, SIA 180 and ÖNorm B8110-2.
- Airtight outdoor joints, e.g. vapour check for external roof insulation or sub-and-top refurbishment vapour check for re-roofing.
- Wind-proof bonding of roof underlay and facade membranes.
- Greater resistance to high humidity on site.

Technical Details

Material/s: Non-ageing acrylate polymers, water and denatured alcohol (15%) as solvents

Temperature Resistance: -20°C to 80°C

Cartridge Size: 310 ml – sufficient for approximately 5 – 10 metres. 600 ml refill tubes also available

Service Life: 60 years +

Usage: Interior and Exterior

3rd party accreditation:



ORCON LINE is an airtight joint adhesive on a roll for joining all kinds of vapour retarders and vapour barriers, e.g., pro clima INTELLO PLUS, PE-, PA-, PP-, and aluminum foils to mineral or rough adjacent building elements, such as masonry, plaster, concrete, rough timber, etc. Solvent-free, permanent, frost-proof airtight adhesive. After firmly pressing on the sheet an airtight joint is created which can bear loads straight away.

Features

- Quick, clean and safe application direct from the roll.
- No drying time, extreme immediate adhesion, joint is airtight immediately.
- Simple tear off release paper, prevents adhesion with the surface on the side, protects adhesive from contamination.
- Extendible – if a piece of adhesive bead is missing from the end of the adhesive, pull slightly on the material.
- Waterproof SOLID adhesive without softeners, solvents, emulsifiers and conservation agents.

Technical Details

Material/s: Square profile SOLID adhesive, silicone coated release paper

Colour: Translucent

Temperature Resistance: Long Term -20°C to 80°C

Application Temperature: +5°C

Usage: Interior

Width of adhesive bead: 10mm

Thickness of adhesive bead: 3.5mm

Roll Length: 15 metres

Moisture resistance: Waterproof



► **TIP** if the surface is unstable use Tescon Primer RP first.

pro clima ORCON F

Multi-purpose flexible joint adhesive for indoor and outdoor application



pro clima ORCON LINE

Multi-purpose flexible joint adhesive for indoor application



100 YEARS

UNI TAPE, TESCON No.1 and TESCON VANA have now officially passed the 100 Year Ageing Test.

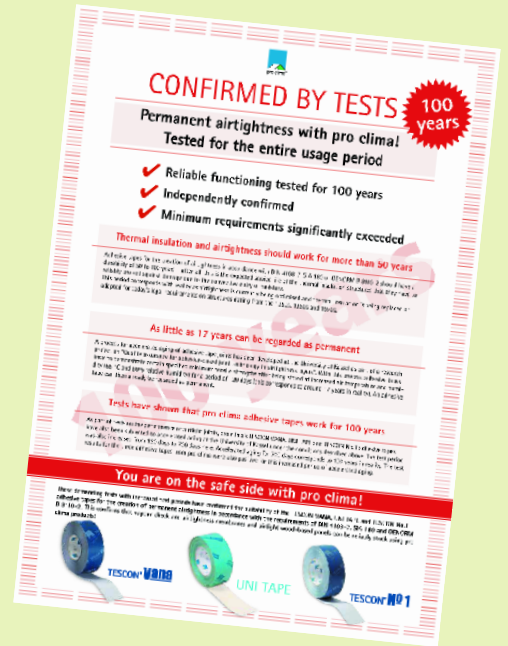
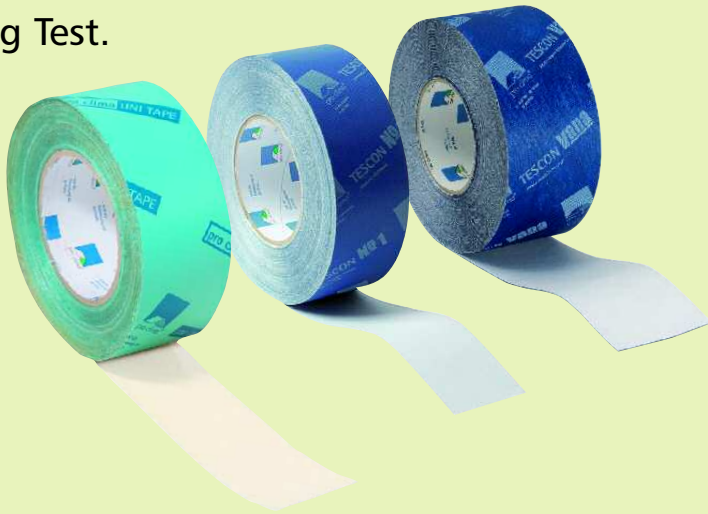

The tapes have been independently tested for artificial ageing at the renowned Fraunhofer Institute at the University of Kassel. The test confirms the high quality and durability of the waterproof SOLID ACRYLIC adhesive glue used in the pro clima tapes.

UNI TAPE is a universal paper based adhesive tape for permanent, airtight and secure bonds indoors in accordance with DIN 4108, SIA 180 and ÖNorm B8110-2.

Features

- UNI TAPE is used for airtight bonding of overlaps between sheets of vapour checks and air-proofing membranes made of sheathing paper or foil as well as joints between such membranes and smooth, non mineral surfaces.
- UNI TAPE is also suitable for sealing butt joints between wood-based panels such as OSB.
- Tears easily. Quick release paper. For internal use only.

Technical Details

Material/s: Special paper with reinforcement layer and siliconized release paper. Acrylate which is free of solvents or softeners

Temperature Resistance: -40°C to 90°C

Roll Width: 6 cms

Roll Length: 30 metres

Service Life: 100 years

Usage: Interior only

3rd party accreditation:



pro clima UNI TAPE

Universal adhesive tape
for airtight bonds
indoors

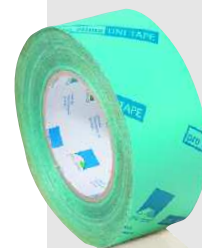

TIP pro clima tapes are supplied with pro clima PRESSFIX to ensure an immediate seal is achieved.

TESCON No.1 is a flexible multi-purpose adhesive tape for airtight bonds indoors and outdoors in accordance with DIN 4108, SIA 180 and ÖNorm B8110-2.

Features

- TESCO No.1 is used to form a secure and permanent seal of overlaps between foil and fleece membranes (Intelligent vapour checks and airtightness membranes, roof underlays and wall membranes) and joints between such membranes and smooth, non-mineral surfaces.
- TESCO No.1 is also suitable for sealing butt joints between wood-based panels such as OSB or MDF sub-roof panels or wood fibre softboards (e.g., Gutex) in combination with TESCO Primer RP.
- Bonds overlaps between sheets of vapour check and joints between wood based panels (such as OSB), also seals service penetrations.
- Offers high protection against piercing in corners due to its high elasticity.
- With release paper.
- Easy to tear by hand.

Technical Details

Material/s: Flexible backing, waterproof SOLID adhesive and siliconised release paper

Temperature Resistance: -40°C to 90°C

Roll Width: 6 cms

Roll Length: 30 metres

Service Life: 100 years

Usage: Interior and Exterior

3rd party accreditation:



TESCON VANA is similar to TESCO No.1 but with a higher tensile strength.

Features

- TESCO VANA is used to form a secure and permanent seal of overlaps between foil and fleece membranes (Intelligent vapour checks and airtightness membranes, roof underlays and wall membranes) and joints between such membranes and smooth, non-mineral surfaces.
- TESCO VANA is also suitable for sealing butt joints between wood-based panels such as OSB or MDF sub-roof panels or wood fibre softboards (e.g. GUTEX) in combination with TESCO Primer RP.
- With release paper.
- Easy to install.
- TESCO VANA is available in 18 x 18 cm patches.

TIP TESCO VANA 150mm wide tape is ideal for wood fibreboard applications with TESCO RP PRIMER

Technical Details

Material/s: PP backing fleece, waterproof SOLID adhesive and siliconised release paper

Temperature Resistance: -40°C to 90°C

Roll Width: 6 cms and 15 cms

Roll Length: 30 metres

Service Life: 100 years

Usage: Interior and Exterior

3rd party accreditation:



pro clima TESCON No. 1

Flexible multi-purpose adhesive tape for airtight bonds

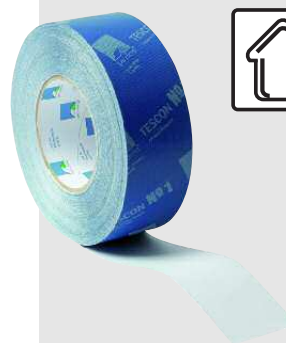

pro clima TESCON VANA

Tensile Multi-purpose adhesive tape for airtight bonds



The airtightness of angled joints is important. Sealing is simplified with the corner adhesive tape **TESCON PROFIL**. It features two release paper strips. This allows you to "activate" a single part of the adhesive surface and to seal corners junction by junction.

Features

- Suitable for sealing reveals at windows, doors, planed timber, corners and roof windows to the Intelligent airtight vapour check.
- Ensures high protection against piercing in corners due to its high elasticity.

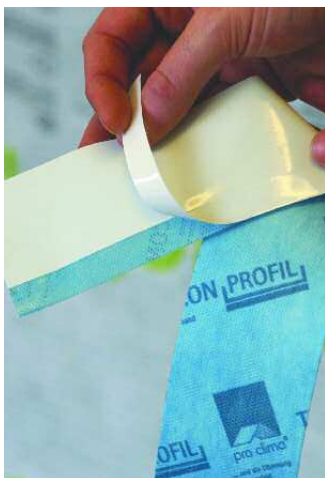

Technical Details

Material/s:	Special PP backing fleece, waterproof SOLID adhesive and split silicone coated PE-film approx. 12 / 48 mm
Temperature Resistance:	-40°C to 90°C
Roll Width:	6 cms
Roll Length:	30 metres

Service Life:	60 years +
Usage:	Interior and Exterior
3rd party accreditation:	

pro clima TESCON PROFIL

Flexible multi-purpose corner tape for windows, doors and corner joints



TESCON INVIS is a black un-branded tape which is excellent for concealing taped joints on pro clima **SOLITEX FRONTA QUATTRO** wall lining membranes behind open jointed back ventilated facades. It can also be used for sealing butt joints between wood-based panels such as OSB or softwood fibre panels.

Features

- For creating invisible bonds and joints behind suspended façades.
- Fully Wind and Waterproof.
- All-round adhesive tape for internal and external use, 6 months out-door exposure.

Technical Details

Material/s:	Special PP backing fleece, waterproof SOLID adhesive and siliconised release paper
Temperature Resistance:	-40°C to 90°C

Roll Width:	6 cms
Roll Length:	30 metres
Service Life:	60 years +
Usage:	Interior and Exterior
3rd party accreditation:	

pro clima TESCON INVIS

Black multi-purpose sealing tape



► **TIP** TESCO INVIS is excellent for concealing taped joints on pro clima **SOLITEX FRONTA QUATTRO** wall lining membranes behind open jointed back ventilated facades.

TESCON NAIDEC is a durable airtight sealing double-sided butyl rubber tape for sealing around nail and screw penetrations making it almost impossible for water to seep in; penetrating deep into the pores of membranes and fibreboards, providing durable sealing around nail holes.

Features

- Nail sealing tape on the underside of a lath on inclined roofs to form a durable seal around nail or screw holes.
- Very good sealing action – penetrates deep into the structure.
- Water resistant.
- Extra-strong due to a reinforcing layer.
- Contains no bitumen.

Technical Details

Material/s:	Non-ageing, bitumen-free butyl rubber	Service Life:	60 years +
Temperature Resistance:	-20°C to +80°C	Usage:	Exterior
Roll Width:	5 cms	3rd party accreditation:	
Roll Length:	20 metres		

► **TIP** To form a durable seal around nail holes position the NAIDEC centrally on the counter batten – firmly secure using a pro clima PRESSFIX.

TESCON Primer RP is a priming coat suitable on wood, wood fibreboards, block structure, roof structure, walls and concrete floors. **Tescon Primer RP** is recommended for the preparation of the surface for the application of pro clima tapes such as **TESCON NO.1**, **TESCON VANA**, and **TESCON PROFIL**, as well as the adhesive compounds **ORCON F/ORCON LINE** and **ECO COLL**.

For a permanent connection the surface should be smooth, dry and stable. Surfaces should be cleaned from any loose materials, dust or sawdust (broom clean). Application of **Tescon Primer RP** is not possible on frozen surfaces. Surface must be suitable for priming. Concrete, sand and cement or skimmed surfaces must be fully cured and dried before **Tescon Primer RP** can be applied.

Features

- Deep penetration into substrate.
- Strengthens the substrate.
- Solvent free.
- Suitable with all pro clima tapes & glues.

Technical Details

Material:	Acryl-Copolymer	Dispenser:	750 and 1000 ml bottle
Temperature Resistance:	-40°C to 90°C	Coverage:	10 square m (1000 ml depending upon porosity of the surface)
Storage:	Frost-free, shelf life 24 months	3rd party accreditation:	
Dissolvent:	Water		

► **TIP** For speedy application no drying of primer is required, bonding to wet primer is possible using **TESCON No1** or **TESCON VANA**.

pro clima TESCON NAIDEC

Double sided butyl
rubber tape



pro clima TESCON PRIMER RP

Priming coat
suitable for wood
fibreboards



CONTEGA SOLIDO SL is an airtight window and door sealing tape with vapour control properties. CONTEGA SOLIDO SL has a full surface adhesive offering extremely strong bonding on mineral surfaces. CONTEGA SOLIDO SL is bonded back to the existing block and can be easily plastered over the top of the fleece face. We always recommend priming the substrate first with TESCON PRIMER RP. Can be used externally if using external wall insulation.

Features

- Vapour retarding and airtight sealing of indoor window and door joints.
- Can be plastered over the fleece side.
- 3 strip adhesive backing available in widths from 80, 100, 150 and 200mm.
- Suitable for both pre and post window & door installation.

Technical Details

Material/s:	PP backing fleece, PP copolymer membrane	Roll Width:	8, 10, 15 and 20cms
Temperature Resistance:	-40°C to 90°C	Roll Length:	30 metres
sd-Value:	2.8m	Usage:	Interior & Exterior with ETICS (EWI)

► **TIP** Use in conjunction with CONTEGA SOLIDO EXO – the exterior Window and Door Windproof diffusion open sealing tape.

CONTEGA SOLIDO EXO is a diffusion open windtight tape for the external sealing of window and doors. With full surface adhesion the tape is fully windproof and resistant to driving rain. The fleece can be easily plastered over in accordance to the application guide. For guidance on a complete internal and external window sealing system refer to our specialised window brochure.

Features

- Vapour permeable sealing of external window and door joints.
- Can be plastered over the fleece side.
- 3 strip adhesive backing available in widths from 80, 100, 150 and 200mm.
- Suitable for both pre and post window & door installation.

Technical Details

Material/s:	PP backing fleece, PP copolymer special membrane. Full surface waterproof non – ageing acrylate adhesive	Colour:	Black
Application Temperature:	Above -10°C	sd-Value:	0.7m
Temperature Resistance:	-40°C to +90°C	Roll Width:	8, 10, 15 and 20 cms
		Roll Length:	30 metres
		Usage:	Exterior

pro clima CONTEGA SOLIDO SL

Vapour resistant window
plaster sealing tape



pro clima CONTEGA SOLIDO EXO

Diffusion open plaster
sealing tape for windows



CONTEGA FIDEN EXO Pre-compressed joint sealing tape for exterior use that is vapour open and resistant to wind driven rain. The tape will continually expand and contract to allow for movement between interfaces while maintaining a full weather tight seal.

Features

- Vapour permeable and highly resistant to driving rain.
- Can be plastered & painted over.
- Tested for driving rain resistance of up to 600pa.
- Suitable for both pre and post window & door installation.

Technical Details

Material/s:	Open Cell Polyurethane flexible foam with Polymer impregnation	Joint gap:	2-3, 3-6, 5-10, 7-12, 8-15, 10-18mm
Temperature Resistance:	-30°C to +90°C	Usage:	Exterior
sd-Value:	0.5m BG1 (DIN 18542)		
Roll Width:	10, 15, 20mm		
Roll Length:	From 2.6 to 10 metres dependent on joint gap		

EXTOSEAL MAGOV is a highly flexible butyl tape for making airtight connections around service penetrations, joist ends and wall to corrugated deck connections.

Features

- Perfect for sealing penetrations as a result of its particularly strong butyl rubber layer and elastic carrier film with low restoring forces.
- Protects from air leakage even when stretched.
- Protects structural elements from water ingress: watertight and blocks rising damp.
- Creates a secure bond: butyl rubber penetrates deep into the substrate.
- Bonds to mineral substrates.

Technical Details

Material:	Butyl rubber	Thickness:	About 2.0 mm (DIN EN 1849-2)
Temperature Resistance:	Permanently -20°C to 80°C	Roll Width:	6 and 10 cm
Colour:	Blue	Roll Length:	10 metres
Application temperature:	5°C to 35°C	Usage:	Exterior and Interior

pro clima CONTEGA FIDEN EXO

Pre-compressed joint sealing tape



pro clima EXTOSEAL MAGOV

Highly flexible butyl tape for making airtight connections



EXTOSEAL ENCORS is a water bearing butyl connection tape with high adhesion strength. EXTOSEAL ENCORS is the ideal weather tight tape for creating robust flashings for window sills and door thresholds and any junctions where there is a likelihood of standing water.

Features

- Protects structural elements from water ingress: watertight and blocks rising damp.
- Extremely high adhesion even to slightly damp and cold surfaces due to the modification of the butyl with Acrylate.
- Very elastic carrier foil and can be flexibly adapted to surfaces and corners.
- Bonds to mineral substrates.
- Seals nail holes.

Technical Details

Material/s:	Butyl rubber modified with Acrylate
Temperature Resistance:	Permanently -20°C to 80°C
Colour:	Black
Application temperature:	-10°C to 35°C
Roll Widths:	10, 15, 20 and 30cm
Roll Length:	20 metres
Usage:	Exterior

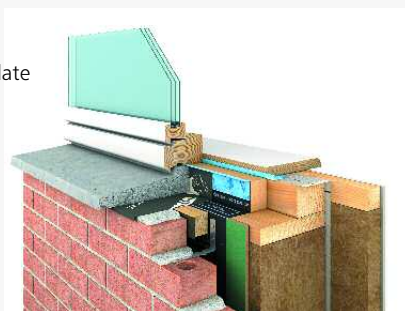

pro clima EXTOSEAL ENCORS

Water bearing butyl connection tape



EXTOSEAL FINOC is an air and moisture tight tape. It can be used for joining wood-based panels to smooth mineral surfaces such as internal timber frame boarding to concrete slab floor. EXTOSEAL FINOC is the ideal watertight capillary break tape used to eliminate rising damp under sole plates.

Features

- Protects structural elements from water ingress: watertight and blocks rising damp.
- Creates a secure bond: Butyl rubber penetrates deep into the substrate.
- Very elastic carrier foil and can be flexibly adapted to surfaces and corners.
- Bonds to mineral substrates.

Technical Details

Material/s:	Butyl rubber	Roll Width:	10, 15, 20 and 30 cm
Temperature Resistance:	Permanently -20°C to 80°C	Roll Length:	20 metres
Colour:	Green	Usage:	Exterior and Interior
Application temperature:	5°C to 35°C		

pro clima EXTOSEAL FINOC

Multi purpose moisture tight butyl tape



If pipes or cables penetrate the airtightness layer, they too must be securely sealed. The most suitable means of doing this is with airtightness grommets made from EPDM. This flexible material allows a tight flexible fit, and ROFLEX is available in all common diameters. ROFLEX grommets should be sealed to membrane with TESCON No. 1/VANA.

Technical Details

Material/s:	EPDM
Temperature Resistance:	-40°C to + 150°C
Grommet Sizes:	<p>ROFLEX 20 15 – 30 mm – 145 mm x 145 mm</p> <p>ROFLEX 30 30 – 50 mm – 140 mm x 140 mm</p> <p>ROFLEX 50 50 – 90 mm – 140 mm x 140 mm</p> <p>ROFLEX 100 100 – 120 mm – 200 mm x 200 mm</p> <p>ROFLEX 150 120 – 170 mm – 250 mm x 250 mm</p> <p>ROFLEX 200 170 – 220 mm – 300 x 300 mm</p> <p>ROFLEX 250 220 – 270 mm – 450 x 450 mm</p> <p>ROFLEX 300 270 – 320 mm – 500 x 500 mm</p>

Service Life: 60 years +
Usage: Interior and Exterior



For sealing solutions we recommend:
TESCON VANA/No.1pg 11



TIP Ask about pro clima Stoppas airtight plugs for conduits.

If pipes or cables penetrate the airtightness layer, they too must be securely sealed. The most suitable means of doing this is with airtightness grommets made from EPDM. This flexible material allows a tight fit, and KAFLEX allows for a secure feed-through for cables and pipes. KAFLEX cable grommets feature an integrated adhesive with a release paper for ease of application.

Features

- For an airtight seal around pipes and cables which pass through the Intello Plus or DB+ membrane. They are made of non-ageing elastic EPDM rubber in a high adhesive square.
- With release paper.
- Offers high protection against piercing due to its high elasticity.

Technical Details

Material/s:	EPDM acrylate solvent-free adhesive tape
Temperature Resistance:	-40°C to +150°C
Grommet Sizes:	<p>KAFLEX Mono Single Cable 6 – 12 mm – 145 mm x 145 mm</p> <p>KAFLEX Duo Twin Cable 6 – 12 mm – 145 mm x 145 mm</p> <p>KAFLEX Multi - up to 16 cables 6 – 12 mm – 140 mm x 140 mm</p>

Service Life: 60 years +
Usage: Interior and Exterior



pro clima ROFLEX

Airtightness grommet
for pipework



pro clima KAFLEX

Airtightness grommet
for cables and small pipes

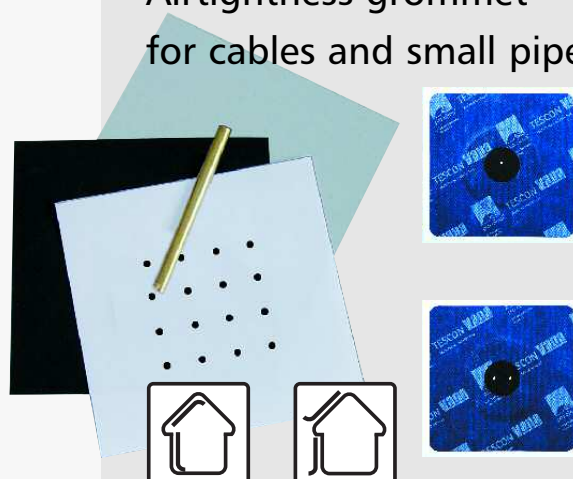

pro clima INSTAABOX is used for the airtight installation of service boxes, without a service void on the interior of external walls. It is designed for making airtight connections on vapour check and airtightness layers indoors, for example; pro clima INTELLO PLUS, DB+ and wood-based panels such as OSB.

Features

- Installation box for creating space for junction boxes, etc., in buildings without a service void behind the dry lining.
- Meets the requirements of DIN 4108-7, SIA 180 and Ö Norm.
- B8110-2 with regard to airtightness for the use of standard service boxes.
- Can be used on both interior and exterior walls and all common substrates used in construction.
- For up to 3 junction boxes.
- Pre-punched exit points for cables.
- For cables up to 20mm in diameter.

For sealing solutions we recommend:
TESCON VANA/No.1 pg 11

Technical Details

Material/s:	Flexible polyethylene
Temperature Resistance:	-10°C to +80°C
Depth:	55mm
Service Life:	60 years +
Usage:	Interior

3rd party accreditation:



► **TIP** Use a nail or ballpoint pen to make the cable penetration through the perforated position on the INSTAABOX.

The pro clima WINCON airtightness quality control unit is a high powered fan designed to pinpoint air leakage on site. It empowers the installer to verify if the airtightness work carried out on site after application is to a high standard. Often referred to as the spirit level for airtightness, it is a high performance, easy to use unit.

Features

- Its operation is based on a simple principle: the pro clima WINCON generates a negative pressure and thereby enables air leaks to be identified and effectively sealed, prior to the application of the internal lining.
- The pro clima WINCON can be installed in an external window or door of the building.
- The pro clima WINCON is an innovative device which consists of a high powered fan, a fan controller and a magnehelic pressure gauge, all mounted on one singular wooden frame.
- This device is packaged in a convenient, robust wooden box, complete with smoke puffers for detecting leakages in the building envelope and temporary sealing tapes.
- The magnehelic gauge allows the operator to depressurise the building to up to 60 Pascals.
- Quality control ensures attention to detail during installation.
- The pro clima Wincon does not replace the Blower Door test but it compliments the airtightness testing process.



► **TIP** Carry out intermediate airtightness quality check using the WINCON prior to the application of the internal lining.

pro clima INSTAABOX

Airtight installation of service boxes



pro clima Wincon airtightness quality control unit

An exceptionally high performance quality control device (9600m³/h at 50 Pa pressure differential)

Technical Details

Units available: 220V

3rd party accreditation:





1 INITIAL SITUATION

Insulation is installed between the rafters. Semi-rigid batt insulation material is being used in this case. For optimum insulation performance it is important to ensure that there are no gaps between the insulation batts and the supporting rafters.

Outside the insulation, an insulation protection layer (e.g., SOLITEX PLUS, wood fibreboard or roof lining on wooden planking) should be attached to the rafters to provide wind-proofing. It ensures that cold air does not pass through the thermal insulation and gives optimum insulation.

During colder months, the vapour check and airtightness layer must be fitted and secured immediately after installation of the thermal insulation.

Note on blown insulation: The insulation material should be inserted directly after completion of the airtightness layer with INTELLO PLUS.



2 FIXING THE MEMBRANES

The INTELLO PLUS vapour check and airtightness membrane is laid on the interior, beneath the insulation. Bonding with adhesive tapes should be on the smooth printed side. Staples should be at least 10 mm wide and 8 mm long and set at a maximum distance of 10-15 cm.

INTELLO PLUS can be unrolled and stapled either lengthwise or crosswise to the rafters. It should be laid as far as possible without creasing.

The lengthwise technique is shown here. With this technique there is usually less waste. For sealing later it is important to extend the vapour check approximately 3 cm onto the gable wall or jamb wall and fasten if possible using staples. This joint is sealed air tightly later.



Note on blown insulation: The maximum staple spacing is then 5 – 10 cm.



3 OVERLAP THE MEMBRANES

Once the first membrane is in place the second layer is fitted. The membrane may overlap by about 10 cm. The printed markings are an aid to orientation.



4 PREPARATION

Surfaces should be brushed down before bonding. Dust should be vacuum cleaned or wiped with a cloth.

All surfaces must be suitable for permanent, airtight adhesion with airtightness tape and joint adhesive, and must be stable, dry, smooth and free of dust, silicone and grease.

Adhesion to frozen surfaces is not possible. When it comes to protecting the structure, the best results can be achieved with high-quality vapour checks and airtightness membranes and timber derived sheathing. In case of doubt, adhesion tests should be carried out.

TIP Tescon Primer RP is recommended for the preparation of concrete/masonry or porous surfaces prior to bonding.



5 SEAL

Once the vapour check is fitted it has to be sealed. The membranes should be sealed at overlaps without strain or loading, using TESCON No. 1, TESCON VANA or UNI TAPE. Creases in the overlap area must not be over-taped; they must be cut off and re-sealed. The tape should be applied centrally and pressed down firmly using, for example pro clima PRESSFIX.



6 JAMB WALL

Just as important as the sealing of overlaps are joints to adjacent structural components. TESCON No.1, TESCON VANA or UNI TAPE is used for joints to smooth, non-mineral structural components (such as this jamb wall made of OSB panels). Gable walls are treated similarly.

The joint adhesive ORCON F is applied to adjacent mineral structural components or rough wooden components (e.g., plastered walls or rough timber) with a continuous bead of approximately 5 mm thick ORCON F.

With rough surfaces, increase the bead size as required. Glue the vapour check, with an expansion joint, to the adhesive bead. To allow for movement, do not press the glue completely flat. Pressure laths are usually not required on stable surfaces.



7 GABLE (plastered)

For joints to plastered gable walls, a continuous bead of approximately 5 mm thick ORCON F multi-purpose joint adhesive should be applied from the cartridge. With rough surfaces, increase the bead size as required.

Glue the vapour check and include an expansion joint. Adhere to adhesive bead.

To allow for movement of the parts, do not press the glue completely flat. Pressure laths are usually not required on stable surfaces.



GABLE (unplastered)

For masonry which has yet to be plastered, the plaster sealing tape CONTEGA SOLIDO SL gives a secure, airtight seal. Before sticking, the sub-surfaces should be brushed off or wiped clean with a cloth and uneven mineral sub-surfaces may need

to be levelled with a smooth finish. We would always recommend brushing the mineral surface with TESCON PRIMER RP prior to adhering the tape to stabilise the surface.

CONTEGA SOLIDO SL tape is first attached to the smooth side of the vapour check by peeling back the release strip on the reverse, the second section of the tape has full-surface adhesion to the mineral sub-surface. CONTEGA SOLIDO SL can be plastered over. The modified waterproof SOLID adhesive ensures quick and permanent joints with the subsurface. The stuck joint is immediately airtight and can be subjected to loading. CONTEGA SOLIDO SL also creates an interior airtight and vapour-retarding seal of windows and doors to adjacent components made of wood and mineral sub-surfaces such as concrete and sand-lime brick.

► **TIP** See our website for Airtight Installation Videos.
www.ecologicalbuildingsystems.com



8 ROOF BEAM - Purlin

ORCON F joint adhesive is used at rough timber, rafters, purlins or other roof timbers. Apply ORCON F in an approximately 5 mm thick adhesive bead. With rough surfaces, increase the bead size as required.

Lay the vapour check (if possible) with an expansion joint in the adhesive bead. Do not press the adhesive completely flat.



9 CHIMNEY

For connections to insulated, double-layer chimneys, apply approximately 3 cm of INTELLO to the chimney. Apply an approximately 5 mm thick adhesive bead (more if necessary) with ORCON F and lay the membrane, with an expansion joint, in the adhesive bed. Do not press the adhesive completely flat.

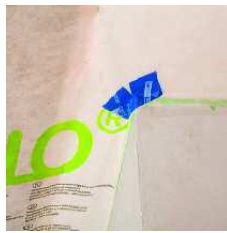

Seal the corners with short pieces of TESCON No. 1. In the centre of the adhesive tape, cut halfway through. Then it is easy to shape.



10 PIPE AND CABLE

If pipes or cables penetrate the airtightness layer they too must be securely sealed. The most suitable means of doing this is with airtightness grommets made from EPDM. This flexible material allows a tight fit, and ROFLEX is available in all common diameters.

KAFLEX cable grommets are self-adhesive. Remove the release paper, push over the cable and stick on. ROFLEX pipe grommets are affixed using TESCON No.1/VANA. Press firmly to secure the adhesive tape.

11 CORNER SEALING

The airtightness of angled joints is also important. Sealing is simplified with the corner adhesive tape TESCON PROFIL. It features two release strips. This allows you to "activate" a single part of the adhesive surface and to seal corners junction by junction.

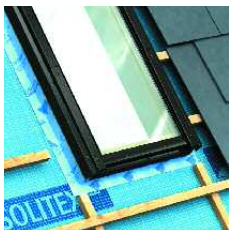

CONTEGA SOLIDO SL (shown on the right) also creates an interior airtight and vapour-retarding seal of angled joints to adjacent components such as joist ends to mineral sub-surfaces like concrete and sand-lime brick, providing the surface has been primed with TESCON PRIMER RP. This tape can be plastered over.

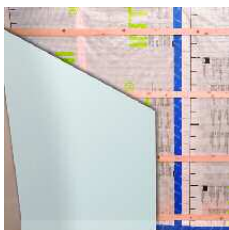

12 COMPLETION

Cross-battens with a maximum spacing of 50 cm should hold the weight of the insulation. An interior lining protects the membranes from damage and UV light.

Once all the joints have been sealed, it is advisable to check the airtightness using a BLOWER DOOR or a pro clima WINCON test unit.



pro clima INTELLO PLUS

Application Guide

APPLICATION

pro clima high-performance system for creating secure vapour check and airtightness layers according to DIN 4108, SIA 180, ÖNorm B8110-2, and to UK and Ireland T.G.D. Part L Airtightness Requirements. Perfect protection for thermal insulation against structural damage and mould.

This extremely high level of security is achieved by the humidity-variable diffusion resistance of the membrane – even in structurally challenging buildings.

ADVANTAGES

- ✓ Outstanding protection against structural damage and mould.
- ✓ For pitched roofs, flat roofs, walls, ceilings and floors.
- ✓ Easy to apply, no splicing or tear propagation.
- ✓ Complete airtightness system with all necessary adhesive agents.

TERMS AND CONDITIONS

The joints must not be systematically or intentionally subjected to strain. When the vapour check membrane is sealed, the weight of the insulating material must be borne by the lathing. Adhesion should be supported by battens if necessary. Press firmly to secure the adhesive tape. Ensure there is sufficient back pressure. Airtight seals can only be achieved on vapour check membranes that have been laid without folds or creases. Ventilate the interior space regularly to prevent build-up of excessive humidity. Use a dryer if necessary. The information provided here is based on practical experience and the current state of knowledge. We reserve the right to make changes to the recommendations given or to make alterations due to technical improvements in the quality of our products. We would be happy to inform you of the current state of the art at the time you use our products.

► **TIP** With blown insulation materials or insulation materials that are prone to sagging, an additional supporting lath should be placed on the connections between the membrane overlaps.

SOLITEX PLUS is the Next Generation of High Performance vapour permeable Underlay. With an impressive range of characteristics such as high Vapour Permeability, Extreme Watertightness, High Nail Tear Resistance and Thermostability, SOLITEX PLUS offers superior protection against condensation risk and extreme resistance against pelting rain. SOLITEX PLUS, from pro clima is a Diffusion-Open vapour permeable membrane.

SOLITEX PLUS contains a monolithic membrane which employs Closed Cell Technology compared to conventional microporous membranes. Closed cell membranes offer superior weather tightness, and at the same time ensure that a significant amount of water vapour is actively removed from the inside of the building structure and diffused to the exterior. The combination of these two properties is the determining factor when it comes to quality and the safety of the roof construction.

SOLITEX PLUS CONNECT is available with a pre-applied tape for ease of installation. See page 23 for more information

Detailed installation instructions are available on request.

Features

- Totally resistant to all wood preservatives, wood treatments or natural wood resins.
- Extreme resistance to wind driven pelting rain.
- Totally resistant to contamination due to on site chemicals.
- Extremely Nail-Tear resistant >350N.
- Extremely Water-Tight WI (BS EN 1928).
- High physical strength.
- High vapour permeability.
- Four ply layer.
- Resistant to ageing.
- Lightweight for ease of handling.



► **TIP** To address air leakage at separating floors a lap of tear resistant SOLITEX PLUS is often used.



For sealing solutions we recommend:

- TESCON VANA/No.1 pg 11
- TESCON PROFIL pg 12
- TESCON NAIDEC pg 13



Windtight Exterior Products

pro clima SOLITEX PLUS

Vapour permeable roof underlay



Technical Details

Material/s: Spunbonded 4 reinforced layer polypropylene membrane with TEEE monolithic central membrane

Water Vapour Resistance: < 0.15 MNs/g

Water Resistance: > 2.5m

Nail Tear Resistance: > 350N

Fire Rating: E

Temperature Resistance: -40°C to +100°C

3rd party accreditation:



3rd party product endorsement: NHBC Standards 2007

Colour: Blue

Roll Width: 1.5 metres (smaller rolls available for window and floor connections)

Roll Length: 50 metres (smaller rolls available for window and floor connections)

Usage: Exterior only

www.ecologicalbuildingsystems.com

pro clima SOLITEX membranes have an impressive range of basic characteristics: diffusion-permeable, rainproof, highly tear-resistant. Quick and safe to work with.

Cover fleece

The robust polypropylene micro-fibre cover fleece is water-resistant and provides optimum protection against the penetration of damp. It protects the specialist film below from damage and UV radiation.

The honeycomb structure guarantees non-slip properties even when wet. It is coloured blue to prevent dazzling when it is being laid.

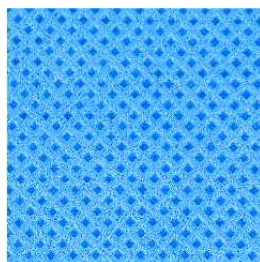

Specialist film

A stretchable, diffusion permeable specialist film gives the pro clima SOLITEX membranes extremely high resistance to water. At the same time, vapour can pass through it almost unrestricted.

In addition, the specific properties of the specialist film ensure the excellent wind resistance properties of the pro clima SOLITEX membranes.

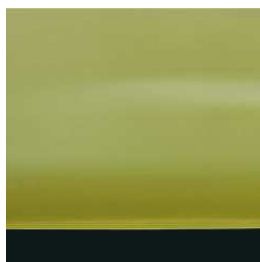

Reinforcement material

The tightly meshed polypropylene reinforcement material doubles the overall strength of the SOLITEX PLUS membrane. If it is used as a sarking membrane, the material is highly effective at preventing the membrane being torn by nails or feet.

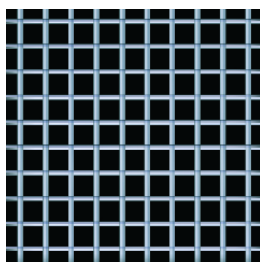

No tent effect

The fact that the pro clima SOLITEX membranes are multilayered prevents the tent effect (tent canvases leak at points of contact). The pro clima SOLITEX membranes can be supported across the whole surface.

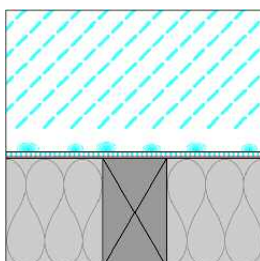

Closed cell technology ensures that dampness can dry more easily and quickly to the outside. This is an advantage both during construction (when the timber may be damp) and during the life of the building.

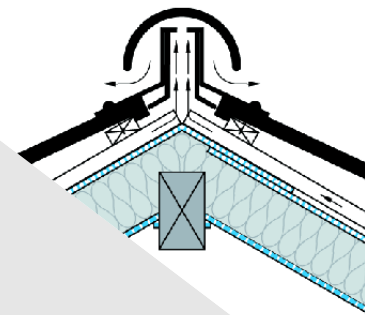
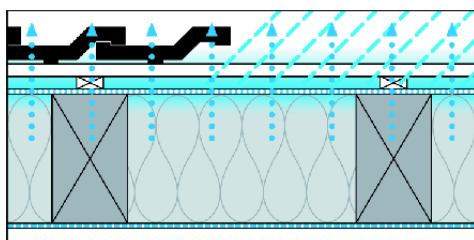

Windtight Exterior Products

pro clima SOLITEX

Sarking, roof lining and wall lining membranes

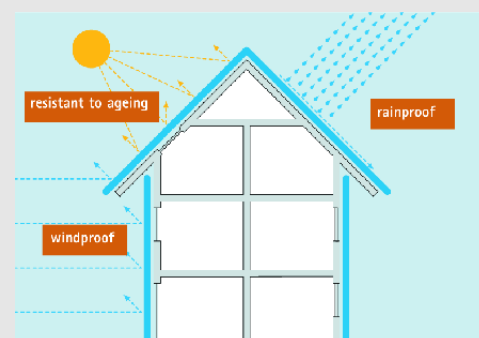

▶ **TIP** Using TESCON NAIDEC a butyl nail sealing tape on the underside of a batten helps ensure a watertight and windtight seal around nail or screw holes.

▶ **TIP** Taping the roof lining membrane increases the waterproof and windproof properties of the roof area.

▶ **TIP** Overlap on the membranes should be at least 10cm. A greater overlap is recommended if the roof pitch is less than the regulation amount.

SOLITEX PLUS CONNECT is a 4 ply diffusion open roofing underlay with 2 integrated self-adhesive strips for rapid wind-proofing from the outside. It offers an ideal solution in helping to ensure compliance with the new British standard for slating and tiling as outlined in BS 5534, where superior resistance to wind loads are required.

Features

- Faster installation due to integrated self-seal strips.
- Extreme resistance to wind driven pelting rain.
- Extremely Nail-Tear resistant >350N.
- Extremely Water-Tight W1 (BS EN 1928).
- High physical strength.
- High vapour permeability.

Technical Details

Material/s: Spunbonded 4 reinforced layer polypropylene membrane with TEEE monolithic central membrane

Water Vapour Resistance: < 0.15 MNs/g

Water Resistance: > 2.5m

Nail Tear Resistance: > 350N

Fire Rating: E

Temperature Resistance: -40°C to +100°C

3rd party accreditation: 

Colour: Blue

Roll Width: 1.5 metres

Roll Length: 50 metres

Usage: Exterior only

SOLITEX UM connect is for use as a diffusion-open underlay with 3D separation layer and butyl self-adhesive strips. It is suitable for ventilated and unventilated structures in combination with any type of roofing or facade materials such as titanium zinc, aluminium, stainless steel, galvanised steel, copper, etc.

Features

- 3D separation layer – 8mm thick 3D separation layer made of spun-bonded PP fabric ensures constant air circulation of the underside of the sheet metal.
- Provides reliable protection against permanent damp and corrosion.
- The soft layer of spun-bonded fabric provides noticeable sound insulation against rain and hail.
- The high-permeability backing layer includes an intelligent membrane. If necessary, it lowers its moisture variable-diffusion resistance to an mvtr-value of 0.05 MNs/g, ensuring maximum drying of the planking and rafters.
- Integrated butyl rubber self-adhesive strips.

Technical Details

Material/s: Spunbonded 4 ply layer with 3D separation layer with 2 self adhesive zones, polypropylene membrane with TEEE monolithic central membrane, entanglement layer of polypropylene

Water Vapour Resistance: 0.1MNs/g

Water Resistance: > 2.5m

Nail Tear Resistance: > 130N

Fire Rating: E

Temperature Resistance: -40°C to 100°C

Colour: Light Blue

Roll Width: 1.4 metres

Roll Length: 25 metres

Usage: Exterior only

3rd party accreditation: 



pro clima SOLITEX PLUS CONNECT

4 ply diffusion open roofing underlay with 2 integrated self-adhesive strips



pro clima SOLITEX UM CONNECT

4 layer roofing underlay with 3D separation layer

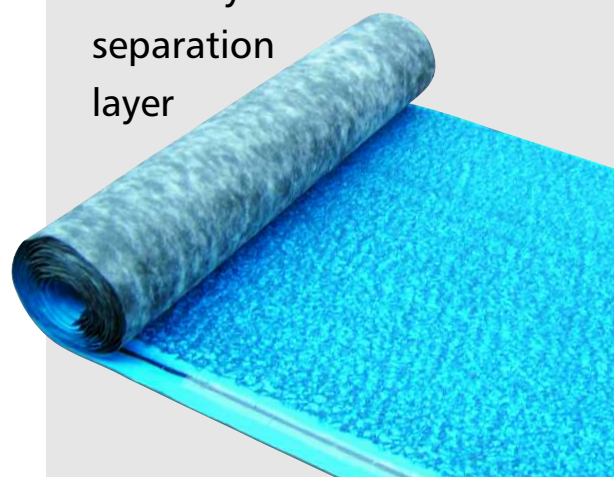

SOLITEX FRONTA WA is a monolithic fully windtight breather membrane specially designed to protect and enhance timber frame structures. It can be applied in the factory to the external face of pre-fabricated wall panels, or on site to timber frame wall assemblies.

Features

- Strong, 3-ply structure for protecting the wall structure.
- Protective function as a result of nonporous functional membrane that actively manages moisture.
- High nail tear resistance.
- For use behind closed façades.
- 3 months outdoor exposure.

For sealing solutions we recommend:

TESCON VANA pg 11
TESCON PROFIL pg 12

Technical Details

Material/s:	Polypropylene microfibre, monolithic TEEE film	Colour:	Black
Water Vapour Resistance:	0.25 MNs/g W1 (BS EN 1928)	Roll Width:	1.5 and 3.0 metres
UV stability and outdoor exposure:	3 months	Roll Length:	50 metres
Temperature Resistance:	-40°C to 100°C	Usage:	Exterior only
Water Resistance:	W1 (BS EN 1928)	3rd party accreditation:	 

SOLITEX FRONTA QUATTRO is a monolithic windtight 3 ply breather membrane suitable for use on open jointed rain screens. Designed with additional UV-exposure resistance which offers the ability create up to a 35mm gap in open jointed cladding.

Features

- Highly diffusion-permeable, but with maximum resistance to wind and driving rain.
- Optimum drying conditions for wall structures: non-porous TEEE functional membrane actively transports moisture outwards.
- Black fleece and print prevents the membrane being visible through open façades.
- Maximum ageing resistance and thermal stability thanks to the TEEE membrane.

For sealing solutions we recommend:

TESCON INVIS pg 12
TESCON PROFIL pg 12

Technical Details

Material/s:	Polypropylene monolithic	Colour:	Black
UV stability and outdoor exposure:	6 months	Roll Width:	1.5 metres
Temperature Resistance:	-40°C to 100°C	Roll Length:	50 metres
Water Resistance:	0.25 MNs/g W1 (BS EN 1928)	Usage:	Exterior only
		3rd party accreditation:	

SOLITEX FRONTA QUATTRO permanently protects the insulation from wind and rain. For use with open façades of up to 35 mm gap width (boarding width = min. 3 x gap width) in accordance with installation guidelines.



pro clima SOLITEX FRONTA WA

Monolithic fully
windtight breather
membrane
for walls



pro clima SOLITEX FRONTA QUATTRO

UV stable monolithic
windtight 3 ply breather
membrane for
walls



SOLITEX FRONTA HUMIDA is a 3-ply slightly diffusion-resistant wall lining membrane for use behind ventilated brick and stone walls. It is used in conjunction with soft wood fibre boards, for example GUTEX MULITHERM behind ventilated clad walls.

Features

- Protects the wood and insulation construction from moisture entering from the outside, caused by the damp environment in an air layer behind masonry facing walls.
- Slightly inhibitory sd value allows moisture to dry out from the construction.
- Slightly diffusion inhibiting.
- Protects the wall construction against moisture from the back ventilation layer.
- The insulation can, at the same time, dry out in the best possible way.
- Impermeable to driving rain: protects against moisture entering from the outside during the construction phase.

For sealing solutions we recommend:

TESCON VANA pg 11

TESCON PROFIL pg 12

Technical Details

Material: Polypropylene microfibre membrane monolithic polymer mixture

UV stability and outdoor exposure: 3 months

Temperature Resistance: -40°C to 100°C

Water Vapour Resistance: 2.5 MNs/g W1 (BS EN 1928)

Fire Rating: E

Colour: Anthracite

Roll Width: 1.5 metres

Roll Length: 50 metres

Usage: Exterior only

3rd party accreditation: 

PASSIVE EcoWall combines high levels of energy efficiency and safety from potential problems associated with condensation risk. With minimum embodied energy, and high levels of comfort and health, using natural materials with a significantly reduced carbon foot print.



Internal EcoWall Construction



External EcoWall Construction



pro clima SOLITEX FRONTA HUMIDA

3-ply slightly diffusion-resistant wall lining membrane for walls



PASSIVE EcoWall

Ecological, Diffusion Open Construction

Passive EcoWall combines the following low energy materials:



 VapourBlock®

 GUTEX®
NATURALLY MADE FROM WOOD



Please don't hesitate to contact our team to discuss further technical and product supply details.

www.ecologicalbuildingsystems.com

Airtightness best practice dictates that surface penetrations of the external envelope should be minimised. Downlights present particular challenges for airtight design and continuity of the insulation layer. However, if downlights are present there is a robust solution in the **OPTIME** Downlight Protector housing units.

Designed as an innovative one stop solution for achieving a safe, easy to install sealing system for downlights. Optime Downlight Protector housing boxes are offered in either Maxi or Mini housing units. The Optime Maxi will accommodate a transformer, the Mini is suitable only to house the downlight. Downlight Protector Mini is designed to suit all types of roofs and ceilings as it is very suitable in narrow places. Optime Downlight Protector boxes significantly reduce the carbon footprint of buildings which incorporate downlights as well as improving comfort and minimising problems associated with condensation in cold attics.

While the Optime Downlight housing is made from a non-flammable materials Optime Downlight is not to be relied upon as a fire barrier.

Features

- The Mini is especially made for narrow spacings - 200 x 200 x 140 mm.
- Simple to install.
- Can be used for most conventional timber ceilings.
- Ensures an effective moisture barrier is maintained.
- Optime Downlight Protector Mini/Maxi should only be used with low wattage downlights.
- Made from inflammable material.
- Optime Downlighters are NOT fire rated.
- Recognised by Nemko.
- Made from recyclable material.
- It is important that the downlight is positioned at the centre of the box.
- Optime Downlighter Protector Mini/Maxi should not be used in wet rooms.

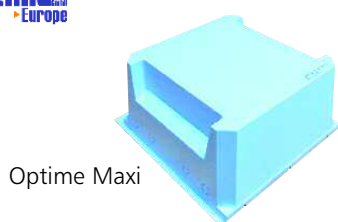

Optime Maxi



Optime Mini



The Optime housing contains a number of perforations. These may be removed as required and the resulting hole may be sealed with a pro clima STOPPA grommet to maintain a flexible airtight seal.

► **TIP** Ask about pro clima Stoppas airtight plugs for conduits.

Optime Downlight Protector Mini/Maxi

Airtight Flush mounted housing for downlights

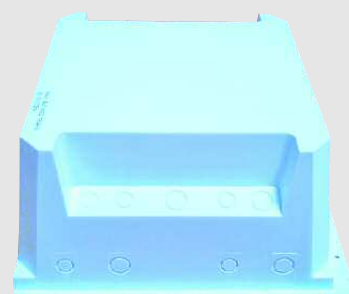

Technical Details

The transformer is NOT to be placed within the Downlight protector Mini, since the size of the box causes too high a temperature for the transformer. The transformer should either be mounted externally or by using the Downlight Protector Maxi. Downlight protector Maxi is also available with a flexible mounting as illustrated above.

3rd party accreditation:



Optime Mini size: 200 x 200 x 140

Optime Maxi size: 320 x 320 x 160

pro clima Stoppa

Airtight plugs for conduits

As part of our airtight range we are also delighted to bring you the **Wellhofer 4D** attic hatch which is insulated and pre sealed for airtightness. Manufactured and engineered in Germany and has been tested to stringent DIN standards to comply with airtightness and insulation requirements. The **Wellhofer 4D** hatch remains airtight even under blower door test conditions.

Features

- An airtight seal of the door itself is maintained by means of a pre-stressed spring which ensures the door remains airtight, even when a blower door test is carried out.
- The gap between the door and the hatch is sealed with a rubber gasket. This durable seal has been tested against ageing.
- An Airtight sealing system ensures that no air leakage occurs from the gap between ceiling and frame. This is due to the double sided adhesive tape and Insulation strip.
- Includes a pre-insulated layer. 0.78 W/m²K for Complete Hatch system.
- The proprietary certified frame-sealing system is ideal for connection to airtight vapour control layers.



wellhöfer
ATTIC HATCHES

Airtight pre-insulated attic hatch

Pre-sealed for airtightness



DIN EN
14975
(2007-01; Reg.Mr. 001)

Wärmeschutz
4D
Druckdichtverriegelung
Dichtung
Dachraumabschluss
wellhöfer

Standard Size
(size of ceiling opening in cms)

Length	120
Width	60
Height	25

The finished measurement of the casing is 1.5 cm smaller in length and width than the ceiling.

Supplied with ladder.

Certified Airtight pre-insulated Attic Hatch
Access Hatch 600 x 600mm also available (not
supplied with ladder)

Please contact our sales office for further
information or test reports.

Ecological Building Systems has been at the forefront of environmental and sustainable building product solutions for over a decade, gaining the sole agency in Ireland and the UK for pro clima, the eminent and well established German brand of Intelligent Airtight and Windtight building solutions. Ecological also supply a range of natural insulations and GUTEX wood fibreboards.

The company now distributes the pro clima range through a network of trained stockists, ensuring local supply and superior service. Please telephone or visit our website for your nearest local supplier.

This brochure aims to dispel some of the myths surrounding airtightness and guide you through the full range of pro clima product solutions. However, we also have more technical documents should you require them and our dedicated technical team at Ecological Building Systems are always on hand to offer advice and product solutions for airtightness, windtightness and moisture management.

You can also find full information on our website www.ecologicalbuildingsystems.com



Technical Sales Service and Back Up

Ecological Building Systems is pleased to provide technical advice on how to incorporate pro clima products into different forms of constructions for new build and refurbishment projects.

- We offer a technical sales help-line.
- CPDs and airtight installation training. 
- Specification Clauses available from: 
- Hygro-thermal modelling using WUFI.
- On-site support, where possible.
- Bespoke Training Centre and Showroom in Ireland.
- Free in house drawing review and consultation service.
- Copies of more in-depth relevant reports and samples.
- Help and advice on meeting the requirements of Building Regulations.
- Airtight installation DVD and videos available on our website.
- U Value Calculations and Dew Point Assessments.
- Airtightness & Windtightness construction details available on request.

The information provided by Ecological Building Systems is based on practical experience and the current state of knowledge. We reserve the right to make changes to the recommendations given or to make alterations due to technical developments and associated improvements in the quality of pro clima's products. Advice and recommendations are given in good faith as a general guide and a service to designers, contractors and manufacturers.

Products in this catalogue have been independently certified by the following organisations:



Ecological Building Systems are proud to be members of and associated with the following organisations:



Printed on 100% recycled Revive silk, using vegetable based inks

4th Edition 2015

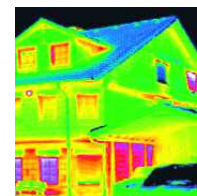
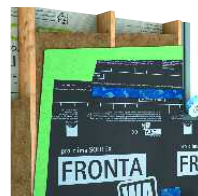
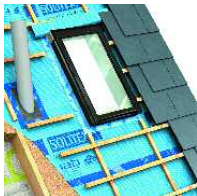

For Stockists contact

Ireland

T. +353 (0) 46 9432104

F. +353 (0) 46 9432435

UK

T. +44 (0) 1228 711511

F. +44 (0) 1228 712280

E. info@ecologicalbuildingsystems.com

www.ecologicalbuildingsystems.com