

System and product brochure

Sealing systems for professionals

WINDOWS



Background knowledge for reliable planning and implementation of window joints

The challenges – What windows have to withstand



Sunlight



Driving rain



High temperature differences



Wind



External noise



Movement of the building
structure

The requirements – Wishes of clients and investors



Energy savings



Avoiding damage to
structures and mould



Living comfort



Protection against weathering



Natural lighting



Fire protection



Movement of the frame



Moderate temperatures



Indoor air humidity



Ventilation



Self-weight

Joints to other building components are always challenging: they are just a few millimetres in width, but have to offer the same performance as an exterior wall with a thickness of 40 centimetres. Alongside the external influences that act on a building component, there are also laws and standards that stipulate requirements that joints have to fulfil. The wishes of clients or investors are additional considerations that have to be taken into account. The quality and performance of window joints are dependent on good planning, installation according to the three-layer principle, and the choice of materials used.

Summary

Careful installation is important in order to ensure the performance of the building envelope and to avoid damage to structures and mould. The design principle of three functional layers must be observed during planning and installation.



The design principle – The joint is what counts!

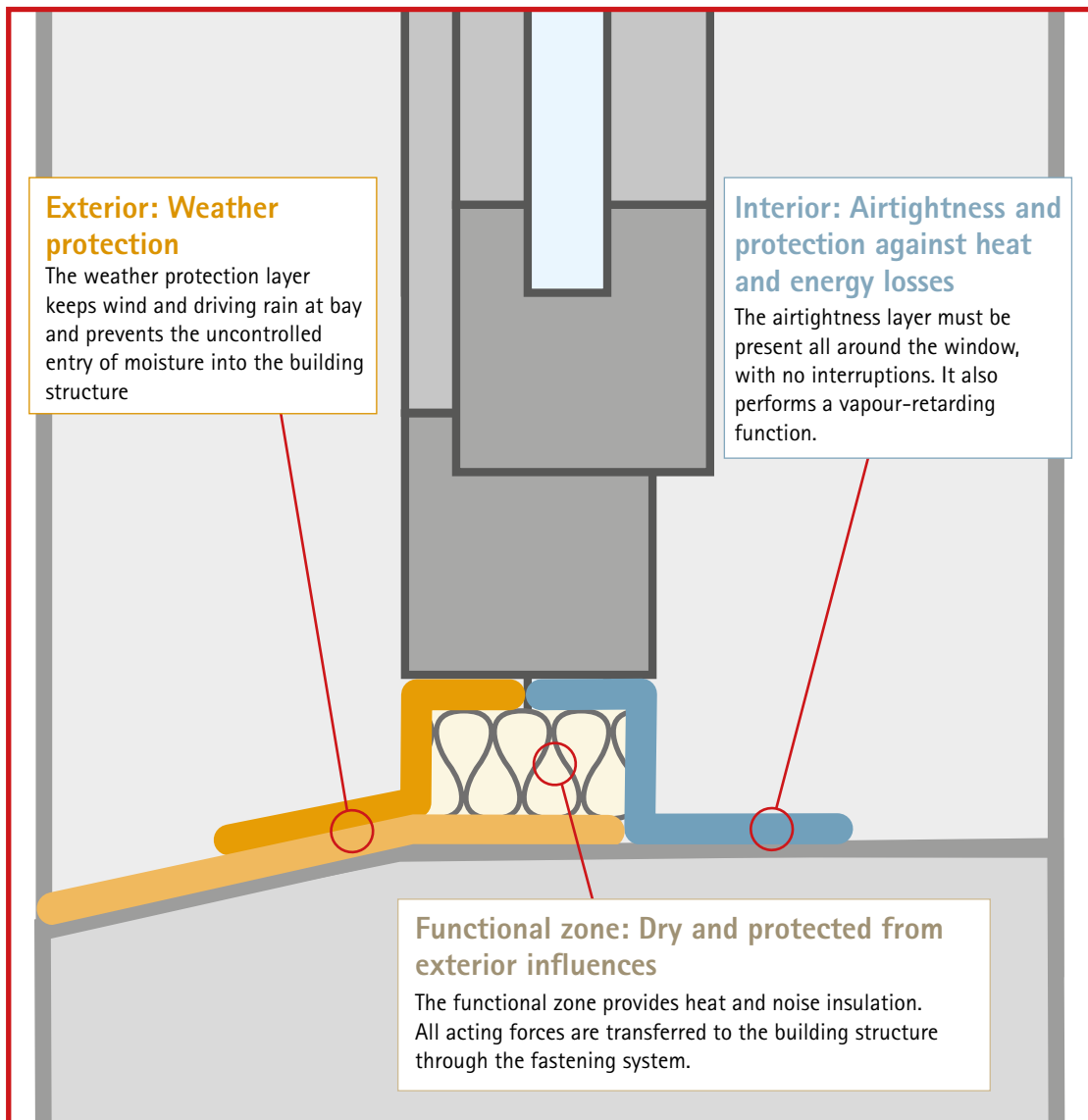



The logic behind the three functional layers

1. Functional zone: Joint insulation

All of the functions of the wall and window have to be performed by joints in an extremely small space. Deficiencies, gaps or flaws in this area directly affect thermal insulation and noise protection. Full performance can only be achieved with a properly sealed and fully insulated joint. The joint determines the quality of the overall building envelope. It acts as a thin separation between the interior and exterior environments. It must be protected against the elements and remain dry and airtight. If the quality of the joint and the joint insulation is neglected, cold and/or damp surfaces could result, which in turn lead to damage to structures and mould.

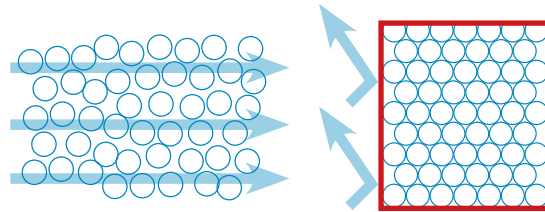

Comparison of unprotected and protected insulation: no air movements in the porous structure are possible on the right. Full insulation effect

2. Interior: Airtightness

A fact that has been taken for granted for many years now for roofs and exterior walls particularly applies to window joints: the performance and reliability of a structure depends on its interior characteristics. One of the most important characteristics for insulated structures is airtightness. In the case of window joints, air currents have an effect on both sides – interior and exterior. In winter, cold air will flow in through any leaks in the joint, cool down interior surfaces and thus create higher air humidities. Mould and condensation can then be expected. If warm room air flows outwards, moisture damage can be expected on the exterior: ice formation, algae, mould. The formation of condensation both inside and outside the structure can lead to significant damage to structures and to mould that is harmful to human health. An airtight joint at the window joint helps to avoid this type of damage to structures as well as risks to human health.

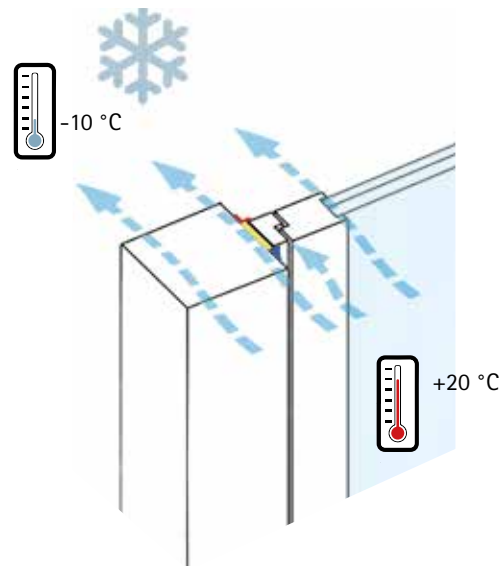

Diffusion flow in winter: Molecular transport of humidity through the building component and joint.

3. Exterior: Weather protection

Windtightness and sealing against driving rain are also crucial components of a reliable, well-protected structure. Weather protection must prevent the entry of water into the building and the structure in order to achieve the optimal, planned performance of the walls and windows. Windtightness prevents the flow of cold outdoor air through the joint insulation; rain protection prevents the entry of rain into the structure and/or joint. The entry of rain from the outside into or through the building structure can lead to failure of this structure or to mould formation. Windtightness ensures the effectiveness of the insulation and prevents local cooling on interior surfaces. Ideally, this layer should be more open to diffusion than the airtightness layer. In this way, any moisture that has entered or any condensation that has formed during wintertime can dry out in the summer. A carefully installed windtightness layer also provides protection against air currents: it thus provides protection against wind, rain and snow.



Protection against rain, snow and wind



Energy savings

Regardless of size and whether a roof or window joint is involved, only an airtight structure is energy-efficient. Airtightness ensures that the joint performs in an optimal manner. This reduces heating costs, and is thus beneficial from both a financial and a climate-protection viewpoint.

A small matter, but a major impact!

Even the smallest leaks in the airtightness layer – e.g. those due to window joints that are not installed properly – allow warm room air to escape quickly to the outside. They thus lead to an increase in heating costs relative to airtight building components. Inadequate airtightness reduces the cost-effectiveness of thermal insulation for building owners.

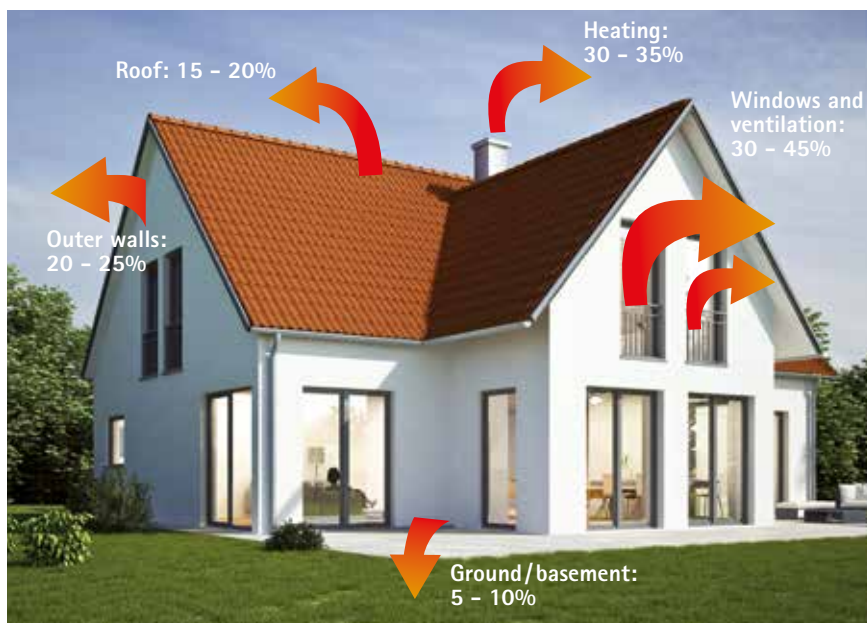
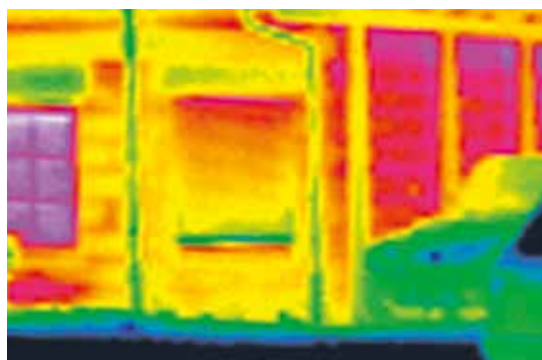

A leaky and insufficiently insulated building envelope causes heating losses, which thus also leads to energy losses. Windows and doors have a major influence on this. This is demonstrated by the following example of a detached single-family house, built in 1984. (Source: saena)

Leaky building envelope: High heating costs

A house with a living space of 80 m² and inadequate airtightness uses just as much heating energy as an airtight house with a living space of around 400 m². A large fraction of the heat losses here take place through the windows and doors. These energy losses can be avoided if building components and joints are sealed in a professional manner. (Source: dena)

Airtight building envelope: Low heating costs

On average, houses in Central Europe consume 22 litres of oil or 220 kWh of gas per m² of living space for heating. For the sake of comparison, a house built to current thermal insulation requirements uses just 3 litres of oil/m² living space, and a passive house only consumes 1 litre.

Summary

Effective airtightness is always the prerequisite for energy-efficient buildings. A leaky building envelope leads to the loss of five times more energy as compared to a sealed building envelope.



Healthier buildings

Effective airtightness protects against mould and prevents draughts. Excessively dry indoor air is avoided in wintertime and rooms stay cooler longer in summer. Joints need to be installed in an airtight manner on the inside to allow the building envelope to perform in this way.



Draughts

Gaps in the airtightness layer result in air flow from the outside to the inside and thus also in a high exchange of air as a result of the large difference in temperature and thus also in pressure between the indoor and outdoor environments. Draughts not only create an uncomfortable sensation, but can also make people sick. If a light air current is continually present, the body gets used to it and the person is then not inclined to take remedial measures against draughts. The mucous membranes and muscles cool down, and colds and muscle tension can result.

Mould

Defective window joints can lead to mould formation.

If humid, warm indoor air enters into a building component through a defective window joint, condensation formation on the inside and thus also mould growth may result. If cold outdoor air enters the building through a leak, the surface temperature drops at the entry point. If warm indoor air meets this cooled-down surface, the relative humidity is increased and condensation may form. There is then a risk of mould on surfaces. Many mould fungi release poisons – such as MVOCs (microbial volatile organic compounds) – and spores as secondary metabolic products that are harmful to human health. Mould is regarded as a leading cause of allergies. It is not important here whether the MVOCs or spores enter into the human body through food, i.e. through the stomach, or through the air into the lungs. Humans should avoid all contact with mould fungi.



Dry indoor air in winter

The frequently observed phenomenon of dry indoor air in winter is a result of the fact that cold outdoor air enters into buildings through gaps. If this cold air is warmed up by heating, its relative humidity content reduces. For this reason, buildings with poor airtightness tend to have air that is too dry in winter, and this cannot be significantly improved by humidification equipment. The consequence is an unpleasant indoor climate.

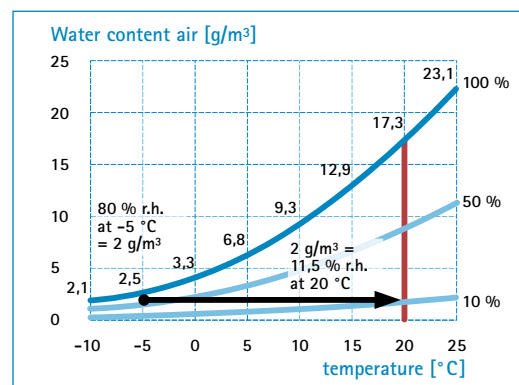

r.h. = Relative humidity

An example

-5 °C cold air at 80 % relative humidity can absorb a maximum of 2 g/m³ of moisture. If this air is heated to 20 °C, the relative humidity falls to 11.5%. This value is much too low for a healthy indoor climate. A relative humidity of 40 to 60% is generally perceived to be pleasant.



Avoiding damage to structures

Damage to structures due to rotting and mould can occur if humid, warm indoor air enters into the functional layer in winter – e.g. through window joints that have not been executed professionally – and condensation is formed. This is avoided if the joint is airtight on the inside. 3 causes of moisture in and on building components:

Condensation

Air has only a certain capacity for holding water that depends on its temperature. There is a high uptake capacity at high temperatures, and a low capacity at low temperatures. If the temperature of the air drops, at first the relative humidity only increases. If the temperature drops even further, the limit curve of the uptake capacity is reached: 100% saturation. If the temperature drops even further again, the air can no longer store its initial water content and condensation forms. As an example, the behaviour of air at 20 °C and 50% relative humidity is described. At 20 °C / 50% relative humidity, 8.65 g water/m³ is stored in the air. If the temperature drops, condensation forms from 9.2 °C onwards: the boundary curve for 100% has been reached. If the temperature drops even more, an increasing amount of condensation is formed and the risk of damage to structures increases.

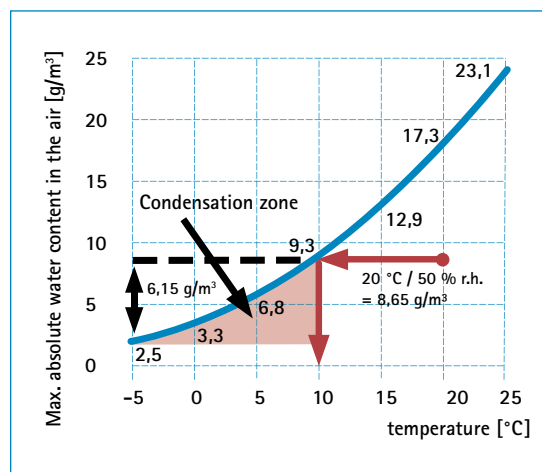

r.h. = Relative humidity

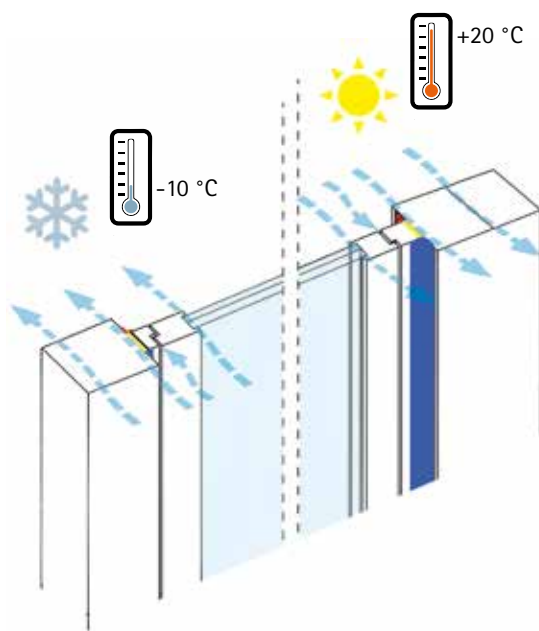

Diffusion

Vapour diffusion refers to the process of moisture transport by means of molecular movement. The driving force is the difference in vapour pressure between the outdoor and indoor environments. In contrast with convection, moisture transport takes place not by means of an air current, but rather through the movement of water vapour molecules through the building component. The diffusion flow is generally from the inside to the outside in winter, and from the outside to the inside in summer. The diffusion flow is regulated by the differing resistances (s_d values) of the individual material layers. An outer layer (e.g. joint sheeting for the window joint) with a low s_d value allows a lot of moisture to leave the structure. A good design principle is: a building component should become increasingly open to diffusion as you move towards the outside. Layers that have variable s_d values facilitate intelligent management of moisture and help to achieve balanced conditions in the structure.

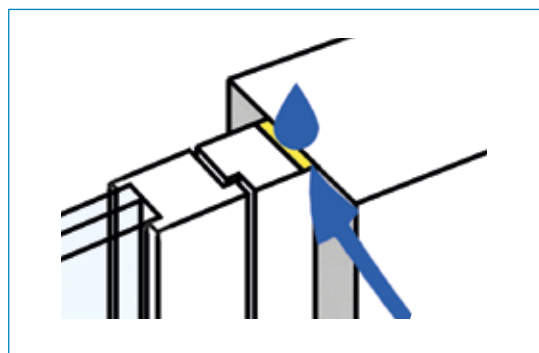

Convection

Convection is an air current – resulting in this case from leaks in the building envelope. It is driven by two factors: incident wind flow to the building and pressure conditions inside the building. Temperature distribution, volume and building height are additional driving factors inside the building for convection. Air currents, i.e. the convective transport of humidity through and/or into a building component must be avoided. After all, the amount of moisture transported by convection is several times greater than that transported by diffusion processes; indeed, the amount of moisture that enters by convection can easily be 1,000 times greater than that entering by diffusion.



Protection against moisture and mould

The interior and exterior sealing layers must be correctly installed and must work properly in order to prevent damage to structures and risks to human health.

The interior and exterior sealing layers are not closed

Humid, warm indoor air flows through the joint. Condensation is formed. Precipitation water from the outside penetrates into the wall structure.

Disadvantages:

- ✘ The functional layer becomes damp
- ✘ Uncontrolled heat losses
- ✘ Draughts
- ✘ Risk of complete failure of the building component
- ✘ Risk of mould formation

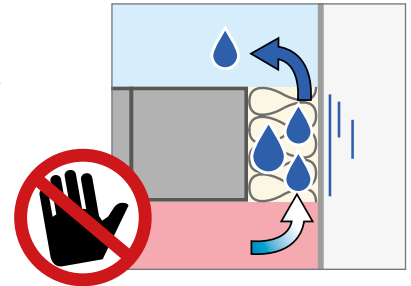

The interior sealing layer is not closed, the outer sealing layer is closed

Humid, warm indoor air flows through the joint. Condensation is formed.

Disadvantage:

- ✘ The functional layer becomes damp
- ✘ The performance of the insulation is reduced
- ✘ The structure becomes damp
- ✘ Risk of mould formation



The interior sealing layer is closed, the outer sealing layer is not closed

The joint is not protected against wind and rain on the outside. Moisture can enter.

Disadvantages:

- ✘ The functional layer becomes damp
- ✘ Uncontrolled heat losses
- ✘ Risk of mould formation

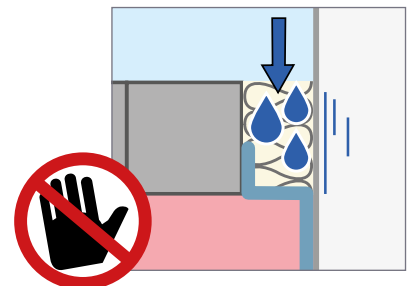

The interior sealing layer is airtight and vapour-retarding, the exterior sealing layer is designed to be windtight, resistant to driving rain and open to diffusion

Humid, warm indoor air does not flow through the joint, the functional layer is insulated and does not act as a thermal bridge. The outside of the building structure joint is protected against wind and rain, moisture that has entered in an unforeseen manner can dry out again.

Advantages:

- ✓ The functional layer is protected
- ✓ Draughts are avoided
- ✓ No heat losses

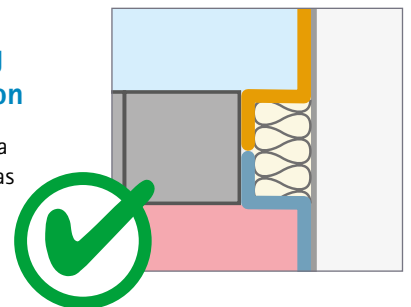

Summary

Correct installation of the joint is crucial!

1. Interior sealing layer = Airtight and vapour-retarding
2. Functional layer = Securely fastened, provides thermal and noise insulation
3. Exterior sealing layer = Windtight, resistant to driving rain and open to diffusion

Only if these three principles are adhered to can energy-efficient joints that are free of damage be achieved.



Installation position and effects of this position

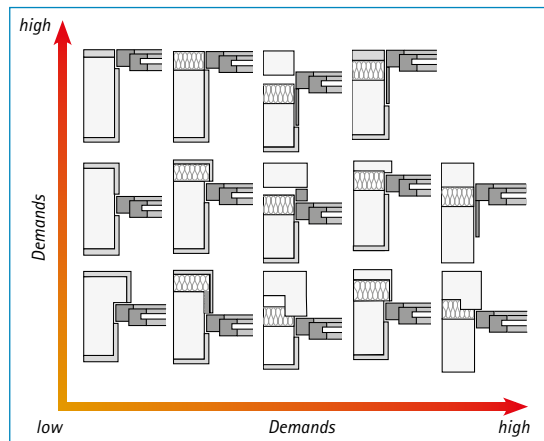

Demands on the window joint

The installation position of the window in the exterior wall is dependent on the structure of the wall, the possible methods of fastening and sealing, and the design requirements on the interior and exterior. Particular attention should be paid to reducing thermal bridges and to optimised isotherm profiles.

The illustration on the left shows how the demands made of a window increase depending on its installation position.

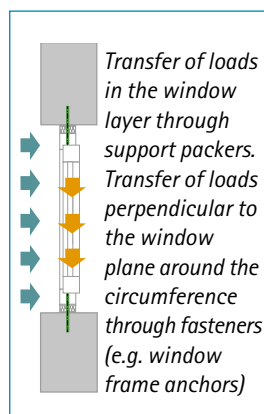

Installation position in the soffit of the supporting structure

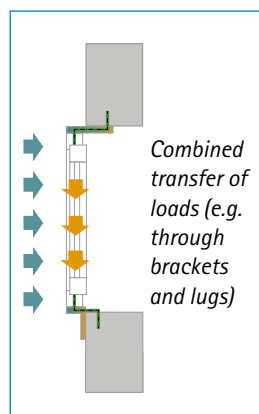

Installation position offset from the supporting structure

Fastening

All forces that can be expected to act on the window must be reliably transferred into the building structure by means of suitable fastening. The installation position determines the choice of fastening system to a significant extent. The transfer of forces into the building structure is to be taken into account accordingly during design.

Acting forces: Self-weight horizontally and vertically, additional loads due to add-on components, wind load, loads from self-weight, vertical and – if applicable – horizontal live loads

Thermal bridges

Thermal bridges refer to thermal weak points (with a higher heat flow density) in structural designs. An increased amount of heat is lost through thermal bridges (transmission heat losses), which leads to a higher energy consumption; in addition, cold surfaces arise at thermal bridges in winter that can favour the formation of condensation and mould. Thermal bridges always occur at window joints as a result of the different thicknesses of the components. Depending on the wall structure, the window frame should be directly adjacent to the insulation of the exterior wall and, if necessary, covered over with insulation in order to reduce thermal bridges.

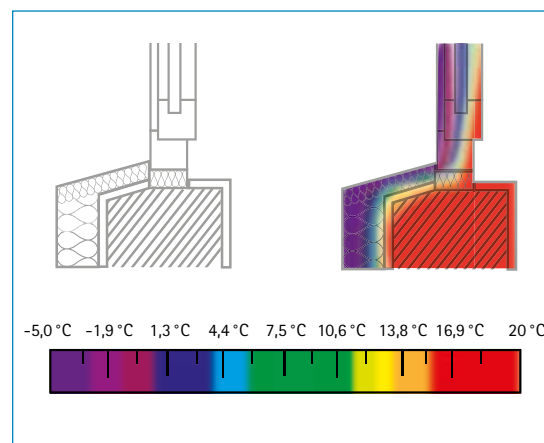



Isotherm curves

Critical temperature for the dew point and for mould fungi

Consideration of isotherm curves is necessary nowadays when planning window installation – due in part to the increase in damage to structures that can be observed. This issue is the basis for professional installation and the reliable sealing of window joints. Isotherms indicate points with constant temperatures within building components. They are calculated on the basis of the conditions in accordance with DIN 4108-2 with an indoor temperature of +20 °C and an outdoor temperature of -5 °C. Condensation can form along the +10 °C isotherm, as indoor air condenses in this range with a standard climate of 20 °C and 50% relative humidity. If this line passes along building component surfaces or is outside of the building component, the indoor air may condense and the surface will become damp. Damage to structures and mould can result. However, consideration of the +13 °C isotherm is even more important in the planning of the position of the window in the building structure. At a temperature of 12.6 °C, the relative humidity (based on 20 °C / 50%) takes on a value of 80%, which represents the start of a risk of mould. If this line lies within the structure, i.e. if the surface temperature is

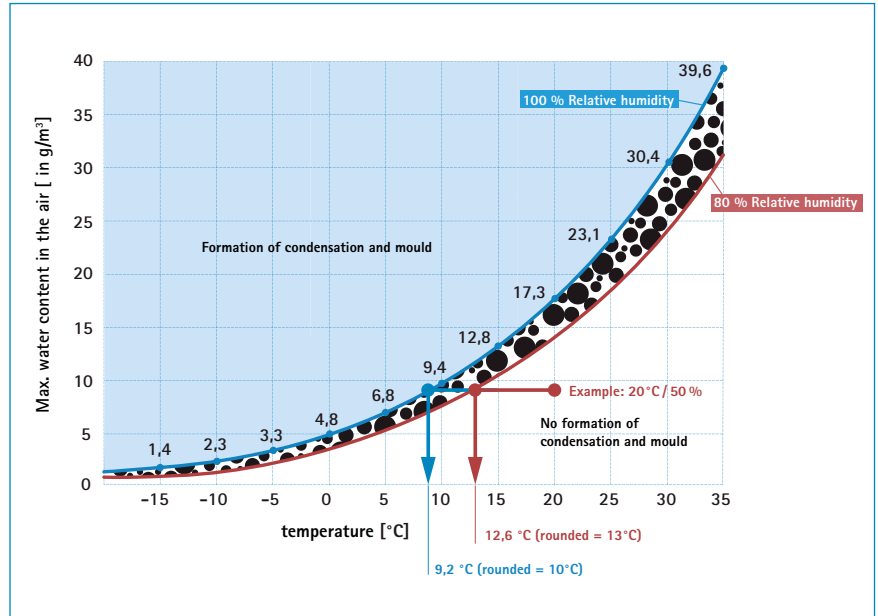

greater than 13 °C, the formation of condensation or mould is impossible from a design viewpoint. After all, the 13 °C isotherm takes into account a longer-term relative humidity of over 80% in the area close to the surface at which mould growth can start to occur.

It all depends on the position!

If a window is positioned too far to the outside, the risk of condensation on the inner window soffit increases. If a window is positioned in the middle of the structure, the outer window soffit may need to be insulated.

In the case of double-shelled wall structures or wall coverings, the windows must be installed in the same plane as the insulation layer or else with sufficient covering of the frame by insulation.

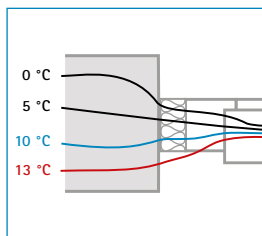

Surface temperature < 13 °C:
Risk of mould formation

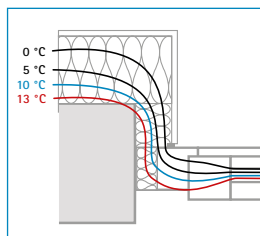

Surface temperature > 13 °C:
Non-critical building component

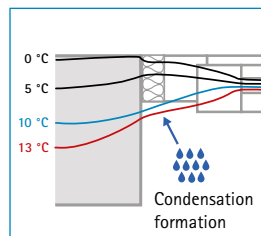

Surface temperature < 10 °C:
Risk of condensation formation / mould growth

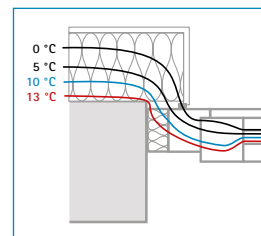

Surface temperature > 13 °C:
Non-critical building component

— 10 °C isotherm, dew-point temperature
— 13 °C isotherm, critical temperature for mould

Summary

The right installation position is crucially important!

- ✓ Insulation covering of the frame reduces thermal bridges
- ✓ The 13 °C isotherm must run through the structure in order to avoid surface mould
- ✓ A recessed installation position reduces weathering exposure and the susceptibility to damage



Joint adhesive tapes for masonry and concrete structures

The joint adhesive tapes for windows and doors in the CONTEGA family can be installed in a simple, practical manner and are very resistant to ageing. These tapes can also reliably accommodate relative motion between building components and remain absolutely airtight and resistant to driving rain in this case. They have demonstrated these capabilities under the most demanding conditions in experiments on building components as part of IFT tests in Rosenheim.

Exterior weather protection

CONTEGA[®] SOLIDO EXO-D

Full-surface adhesive window sealing tape for exterior use with an additional adhesive zone on the fleece side



page 28

Exterior + Interior

AEROSANA[®] VISCONN

Sprayable airtightness sealant with a humidity-variable s_d value (g value, permeance)



page 40

Self sealing sill flashing

EXTOSEAL[®] ENCORS

Water bearing adhesive sealing tape with high adhesion strength



page 16

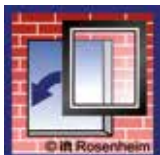

IFT testing

IFT testing of building components at the Institute for Window Technology in Rosenheim demonstrates to project planners and installation technicians that the tested tapes reliably and permanently fulfil even the most demanding requirements for window and door joints. Further information on documented verification is presented alongside each particular product.

Exterior

Interior

Exterior + Interior

CONTEGA[®] SOLIDO IQ-D

Intelligent full-surface adhesive window sealing tape for interior and exterior use with additional adhesive zone



NEW page 34

CONTEGA[®] IQ

Intelligent window sealing tape for interior and exterior use. With the RAL quality seal, product quality monitored by a third-party body



page 36

Interior air sealing

CONTEGA[®] SOLIDO SL-D

Full-surface adhesive window sealing tape for interior use with an additional adhesive zone on the fleece side



page 22

Additional joint adhesive tapes

CONTEGA FIDEN EXO
Pre-compressed joint sealing tape for exterior use **page 38**

CONTEGA SOLIDO SL
Full-surface adhesive plaster and window sealing tape for interior use **page 20**

CONTEGA SOLIDO EXO
Full-surface adhesive plaster and window sealing tape for exterior use **page 26**

CONTEGA SOLIDO IQ
Intelligent full-surface adhesive window sealing tape for interior and exterior use **p. 32**



Joint adhesive tapes for timber structures

The joint adhesive tapes for windows and doors in the CONTEGA family can be installed in a simple, practical manner and are very resistant to ageing. These tapes can also reliably accommodate relative motion between building components and remain absolutely airtight and resistant to driving rain in this case. They have demonstrated these capabilities under the most demanding conditions in experiments on building components as part of IFT tests in Rosenheim.

Exterior weather protection

CONTEGA[®] EXO

Window sealing tape for exterior use with three integrated self-adhesive zones

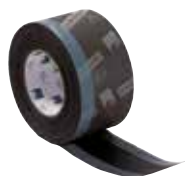

page 30

Exterior + Interior

AEROSANA[®] VISCONN

Sprayable airtightness sealant with a humidity-variable sd value (g value, permeance)



page 40

Self sealing sill flashing

EXTOSEAL[®] ENCORS

Water bearing adhesive sealing tape with high adhesion strength



page 16



IFT testing

IFT testing of building components at the Institute for Window Technology in Rosenheim demonstrates to project planners and installation technicians that the tested tapes reliably and permanently fulfil even the most demanding requirements for window and door joints. Further information on documented verification is presented alongside each particular product.

Exterior

Interior

Interior air sealing

CONTEGA[®] SL

Double-layer plaster sealing tape with vapour control properties



page 24

Exterior + Interior

CONTEGA[®] IO

Intelligent window sealing tape for interior and exterior use. With the RAL quality seal, product quality monitored by a third-party body.



page 36

Additional joint adhesive tapes

CONTEGA FIDEN EXO

Pre-compressed joint sealing tape for exterior use that is open to diffusion and resistant to driving rain

page 38

EXTOSEAL ENCORS

Exterior weather protection

Self sealing sill flashing



EXTOSEAL® ENCORS

Waterproof sealing adhesive tape for interior and exterior use

For creating sub-sill flashing, for window joints with masonry or concrete structures, for joining wood-based panels to smooth mineral surfaces, for sticking underlay panels made of wood fibre to one another (e.g. in roof valleys and transitions) and for bonding these to adjoining building components.

Advantages

- ✓ Excellent protection for building components thanks to strong sealing effect
- ✓ Reliable application: extremely high adhesion even to slightly damp and cold subsurfaces
- ✓ Easy to work with: very elastic - can adapt flexibly to subsurfaces and corners
- ✓ Subsequent work can be started quickly: sticks to stable mineral subsurfaces without primers
- ✓ Proven resistance to driving rain up to 2400 Pa
- ✓ Independently confirmed suitability: tests in accordance with MO-01/1 passed at IFT in Rosenheim (DE)
- ✓ Excellent values in the hazardous substance test, has been tested according to the ISO 16000 evaluation scheme

Waterproof



Professur Nr. 18-000327-7902
 UP 2-103-00010-06-012
 Unterfränkisch EXTOSEAL ENCORS
 mit CONTIGIA SOLING ENG
 nach MO-01/1:2007-01, Abs. 5
 28.06.2016



Technical data

| | | Substance |
|--|-------------------------------|--|
| Backing | | elastic PE carrier film |
| Material | | Butyl rubber modified with acrylate |
| Release film | | silicone-coated PE film |
| Attribute | Regulation | Value |
| Colour | | Butyl rubber: grey, film: black |
| Surface weight | EN 1849-2 | approx. 1.9 kg/m ² |
| Thickness | EN 1849-2 | approx. 1.1 mm |
| s _d -value (g-value Vapour permeance) | EN 1931 ASTM E 96 | > 100 m (> 500 MNs/g < 0.03 US perms) |
| Exposure time | | 6 months |
| Resistance to driving rain | ift, MO-01/1:2007-01, Sect. 5 | up to 600 Pa, self sealing sill flashing |
| Application temperature | | -10 °C to 35 °C 14 °F to 95 °F |
| Temperature resistance | | permanent -40 °C to 80 °C -40 °F to 176 °F |
| Storage | | cool and dry |

Forms of delivery

Length: 20 m; Width: 100, 150, 200 und 300 mm

Substrates

Clean subsurfaces before sticking. Adhesion to frozen surfaces is not possible. There must be no water-repellent substances (e.g. grease or silicone) on materials to be bonded. Subsurfaces must be sufficiently dry and stable. Bonding and joints are possible on planed and painted wood, hard plastics and metal (e.g. pipes, windows etc.), hard wood-based panels (chipboard, OSB, plywood, MDF and wood fibre underlay panels) and mineral subsurfaces such as concrete, non-plastered masonry or plaster. Pretreatment with TESCON PRIMER is required in the case of adhesion to wood-fibre underlay panels. Concrete or plaster subsurfaces must not be sandy or crumbling. Pretreatment with TESCON PRIMER is recommended in the case of subsurfaces with insufficient stability. The best results in terms of structural stability are achieved on high-quality subsurfaces. It is your responsibility to check the suitability of the subsurface; adhesion tests are recommended in certain cases.

General conditions

The bonds should not be subjected to tensile strain. Press firmly to secure the adhesive tape. Ensure there is sufficient back pressure. Windproof, airtight or rainproof seals can only be achieved on vapour retarding membranes, roof lining membranes or façade membranes that have been laid without folds or creases. The tape is self-bonding under the effect of heat.



Installation instructions



1

Tape to the frame

Measure the tape (width of opening + 2 x 20 cm) and cut to size. In stages, remove the narrow release paper gradually and glue to the frame in the window sill recess in stages.



2

Fold up in the soffit

Fold the tape into the corners of the soffit approx. 20 cm high, also glue it to the frame.



3

Tape in the soffit

Piece by piece, release the middle release paper and gradually glue the tape in the soffit. While doing so, guide the tape exactly into the corners. Afterwards, press tape firmly.



4

Cut off vertical excess

Cut off excess tape on the vertical soffits with front edge flush with the hard fibrous insulating board.



5

Cut off horizontal excess

Cut back horizontal excess from the tape to 15 mm using a spacer allowing the tape to later take hold above the plaster.



6

Install the window sill

Finished lower window sill made of EXTOSEAL ENCORS. The plasterer to follow sticks the plaster strip to the overhanging tape section. Final protection of soffit provided by installation of a window sill.

EXTOSEAL ENCORS

Exterior weather protection

Self sealing sill flashing



For use with externally mounted windows

Practical tip

Create a marking in order to achieve a uniform lateral protrusion distance for EXTOSEAL ENCORS at the centre of the window.



Practical tip

To ensure a straight adhesive joint on the front of the window frame, apply markings 1 cm from the outer side of the frame. This is necessary for the joint at the top. This is recommended particularly for the side / bottom joints for plastic windows.

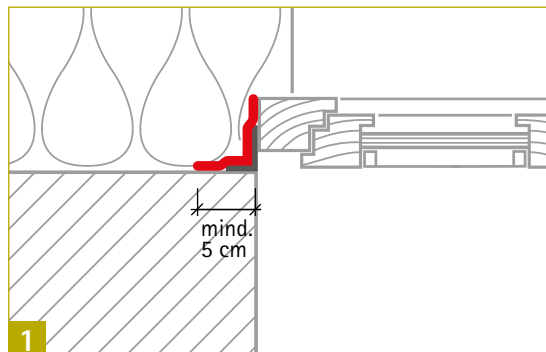

Preparation

Select the width of the tape so that the entire side of the window frame can be covered and that a minimum width of 5 cm of the concrete is covered.



Clean the subsurface

Remove loose material using a brush or vacuum cleaner. Strengthen unstable (e.g. crumbling) subsurfaces with TESCON PRIMER, if necessary.

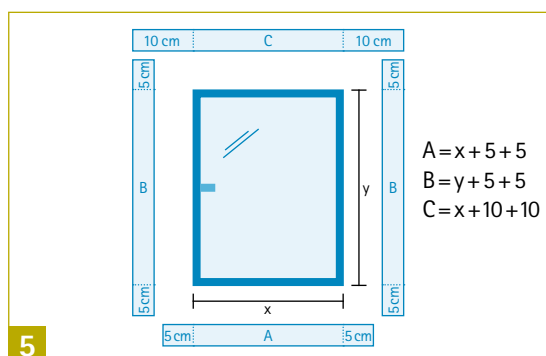

Cut the tape to size

When cutting tape for the bottom and side adhesive tape sections, add 2 x 5 cm to the relevant frame dimension, and add 2 x 10 cm for the top tape piece so that waterproof adhesive bonds can subsequently be created at the corners. If joints are created in a number of parts for a particular side, the tape overlap must be at least 3 cm.



Check the initial situation

The windows and all fasteners must be correctly installed.



Cover brackets

Select the width of EXTOSEAL ENCORS so that brackets are covered by at least 3 cm. The minimum coverage width on the wall is 5 cm. Alternatively, large side lengths can be covered with suitably cut sections of EXTOSEAL ENCORS.



Stick to the window

Create adhesive bonds in a waterproof manner starting at the bottom of the window and working up. Fold the tape to half of its total length and remove the narrow release film strip on one side. Position the tape at the centre of the window and stick in place. Completely remove the narrow release film strip, unfold the adhesive tape and stick it to the window frame.



7

Stick to the wall

To create an adhesive bond with the wall, remove the remaining release film strips and stick the tape to the frame and/or the masonry subsurface. Avoid hollows



between the window frame and the masonry/concrete subsurface so that the thermal insulation material can be pushed right up to the window frame. Rub the adhesive tape using the PRESSFIX application tool to secure it.



8

Create adhesive joints at the corners

Pre-stretch EXTOSEAL ENCORS uniformly so that the adhesive tape can be stuck around the corners of the



window frame both to the frame and to the masonry/concrete without any tension. After sticking, rub the tape firmly into place using PRESSFIX.

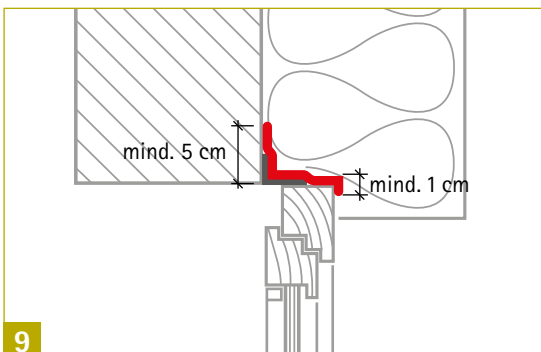

9

Top connection

Guide 1 cm of the upper adhesive joint onto the front of the window frame so that water can run off in waterproof manner. If the distance between the window frame and the wall is greater than 50 mm, it is recommended to use a slope wedge.



10

You're finished!

CONTEGA SOLIDO SL

Interior air sealing



CONTEGA[®] SOLIDO SL

Full-surface adhesive plaster and window sealing tape for interior use

For interior airtight and vapour-retarding joints between windows, doors or airtightness layers and adjacent building components made of wood or mineral substrates such as concrete and masonry, with full-surface adhesion.



Can be plastered over

Advantages

- ✓ Saves time: the joint is immediately airtight and can be subjected to loading
- ✓ Can be plastered over directly: defined transition between window and/or vapour retarder and plaster
- ✓ Reliable joints: waterproof SOLID adhesive has extremely strong adhesion on mineral substrates too
- ✓ Independently confirmed suitability: tests in accordance with MO-01/1 passed at IFT in Rosenheim (DE)
- ✓ Construction in adherence with standards: for airtight bonding in accordance with DIN 4108-7, SIA 180 and RT 2012
- ✓ Excellent values in the hazardous substance test, has been tested according to the ISO 16000 evaluation scheme

Technical data

| | | Substance |
|---|-------------------------------|--|
| Backing | | PP backing fleece, PP copolymer special membrane |
| Adhesive | | modified waterproof SOLID adhesive |
| Release film | | one or two split silicone-coated PE sheet |
| Attribute | Regulation | Value |
| Colour | | white |
| s_d -value (g-value Vapour permeance) | BS EN 1931 ASTM E 96 | 2.8 m (14 MNs/g 1.17 US perms) |
| Airtightness | ift, MO-01/1:2007-01, Sect. 5 | up to 1000 Pa, surrounding |
| Bonding requirement, non-aged/aged | DIN 4108-11 | passed |
| Can be plastered over | | yes |
| Application temperature | | above -10 °C / 14 °F |
| Temperature resistance | | permanent -40 °C to 90 °C ; -40 °F to 194 °F |
| Storage | | cool and dry |

Forms of delivery

Length: 30 m; Width: 80, 100, 150 und 200 mm

Substrates

Clean substrates before sticking. Uneven mineral substrates may need to be levelled with a smooth finish. Adhesion to frozen surfaces is not possible. There must be no water-repellent substances (e.g. grease or silicone) on materials to be bonded. The width of the adhesive tape that is to be plastered over should generally not exceed 60 mm (2 3/8") or 50 % of the soffit area. Detailed recommendations can be obtained from the relevant plaster producer. Substrates must be sufficiently dry and stable. Permanent adhesion is achieved on all pro clima interior membranes and on other vapour retarder and airtight membranes (e.g. those made of PE, PA, PP and aluminium). Adhesion can be carried out on planed and painted wood, hard plastics, hard wood-based panels (chipboard, OSB and plywood panels) and on mineral substrates such as concrete and masonry. The best results in terms of structural stability are achieved on high-quality substrates. It is your responsibility to check the suitability of the substrate; adhesion tests are recommended in certain cases. Pretreatment with TESCON PRIMER is recommended in the case of substrates with insufficient stability.

General conditions

The bonds should not be subjected to tensile strain. Press the adhesive tapes firmly to secure them, taking care to ensure that there is sufficient resistance pressure behind them. Airtight seals can only be achieved if the sealing tape is installed free of folds and breaks. Ventilate regularly and systematically to prevent build-up of excessive humidity. Use a dryer if necessary. When plastering, please observe the recommendations of the plaster manufacturer for non-absorbent substrates. A bonding course may be necessary.



Prüfbericht Nr. 16-000627-FR02
 (P) 1-403-00019-06-012
 - CONTEGA SOLIDO SL
 - CONTEGA SOLIDO ERD
 nach ISO 16000-1:2007-01, Abs. 9
 24.06.2016



Tested for hazardous substances according to

ISO 16000

For healthier indoor air



Installation instructions

→ Situation 1: Window has already been installed



1 Stick to the frame

Begin to carry out the sticking in the corner area. First position approx. 2 cm of the tape on the horizontal part of the frame and stick the adhesive strip to the frame. Guide the tape around the frame corner and stick the tape to the vertical part of the frame. Gradually remove the backing paper while doing so.



2 Stick to the soffit

Gradually remove the second (wide) backing paper strip from the smooth membrane side. Begin to carry out the sticking to the soffit in the corner area. Stick the excess tape to the adjacent soffit side. Stick the tape into the next corner area. Stick the excess tape to the adjacent soffit side.

→ Situation 2: Before the window is installed



1 Stick to the side of the frame

Remove the narrow backing paper strip, position it on the side of the frame flush with the frame edge and then gradually stick in place. The printed side of the tape must be facing upwards here.



2 Stick to the soffit and rub on

Remove the wide backing paper and gradually stick around the circumference of the soffit. Rub using the pro clima PRESSFIX application tool to secure it.

→ Other situations



Masonry gable end wall, creating an airtight joint

Put the vapour retarder in place. Leave slack for expansion so as to allow for relative motion between components. Remove all backing papers from CONTEGA SOLIDO SL. Put the tape in place, gradually stick it, and then rub using the pro clima PRESSFIX application tool to secure it.



Beam penetration in masonry wall

Cut four strips of tape. Remove the narrow backing paper and stick the tape to the first side of the beam. Remove the wide backing paper and stick the tape to the wall. Cut into the tape at the beam corners so that the tape can be stuck to the adjacent beam side. Bond the other sides analogously in an airtight manner.

CONTEGA SOLIDO SL-D

Interior air sealing



CONTEGA[®] SOLIDO SL-D

Full-surface adhesive plaster and window sealing tape for interior use with an additional adhesive zone

For interior airtight joints between windows, doors or airtightness layers and adjacent building components made of wood or mineral substrates, with full-surface adhesion. The adhesive zone on the fleece side allows for easier adhesion to windows and doors if applied before they are installed.



Advantages

- ✓ Saves time: the joint is immediately airtight and can be subjected to loading
- ✓ Easy to work with thanks to the additional adhesive zone on the fleece side
- ✓ Can be plastered over directly: defined transition between window and/or vapour retarder and plaster
- ✓ Reliable joints: waterproof SOLID adhesive has extremely strong adhesion on mineral substrates too
- ✓ Independently confirmed suitability: tests in accordance with MO-01/1 passed at IFT in Rosenheim (DE)
- ✓ Construction in adherence with standards: for airtight bonding in accordance with DIN 4108-7, SIA 180 and RT 2012
- ✓ Excellent values in the hazardous substance test, has been tested according to the ISO 16000 evaluation scheme

Can be plastered over



Prüfbericht No. 13-003205-4803
 (P8-003-00339-06-003)
 = CONTEGA SOLIDO SL-D
 = CONTEGA SOLIDO END-B
 nach MO-01/1:2007-01, Abs. 8
 15.03.2016



Technical data

| | | Substance |
|---|------------------------------|--|
| Backing | | PP backing fleece, PP copolymer special membrane |
| Adhesive | | modified waterproof SOLID adhesive |
| Release film | | one or two split silicone-coated PE sheet |
| Attribute | Regulation | Value |
| Colour | | white |
| s_g -value (g-value Vapour permeance) | EN 1931 ASTM E 96 | 2.8 m (14 MNs/g 1.17 US perms) |
| Airtightness | ift, MO-01/1:2007-01, Sect.5 | up to 1000 Pa, surrounding |
| Bonding requirement, non-aged/aged | DIN 4108-11 | passed |
| Can be plastered over | | ja |
| Application temperature | | above -10 °C; 14 °F |
| Temperature resistance | | permanent -40 °C to 90 °C; -40 °F to 194 °F |
| Storage | | cool and dry |

Forms of delivery

Length: 30 m; Width: 80, 100, 150 und 200 mm

Substrates

Clean substrates before sticking. Uneven mineral substrates may need to be levelled with a smooth finish. Adhesion to frozen surfaces is not possible. There must be no water-repellent substances (e.g. grease or silicone) on materials to be bonded. The width of the adhesive tape that is to be plastered over should generally not exceed 60 mm (2 3/8") or 50 % of the soffit area. Detailed recommendations can be obtained from the relevant plaster producer. Subsurfaces must be sufficiently dry and stable. Permanent adhesion is achieved on all pro clima interior membranes and on other vapour retarder and airtight membranes (e.g. those made of PE, PA, PP and aluminium). Adhesion can be carried out on planed and painted wood, hard plastics, hard wood-based panels (chipboard, OSB and plywood panels) and on mineral substrates such as concrete and masonry. The best results in terms of structural stability are achieved on high-quality substrates. It is your responsibility to check the suitability of the substrate; adhesion tests are recommended in certain cases. Pretreatment with TESCON PRIMER is recommended in the case of substrates with insufficient stability.

General conditions

The bonds should not be subjected to tensile strain. Press firmly to secure the adhesive tapes in place. Ensure that there is sufficient resistance pressure. Airtight seals can only be achieved if the sealing tape is installed free of folds and breaks. Ventilate continuously and systematically to prevent build-up of excessive humidity; use a dryer if necessary. When plastering, please observe the recommendations of the plaster manufacturer for non-absorbent substrates. A bonding course may be necessary.



Installation instructions

→ Situation 1: Before the window is installed



Stick to the side of the frame

Remove the single release film strip on the printed side, position it on the side of the frame and then gradually stick in place. The printed side of the tape must be facing the window (upwards) here.



Corner finishing

Allow CONTEGA SOLIDO SL-D to protrude by about 2 cm in the corner area (length of the corner diagonal of the joint) and stick it in the form of a corner fold.



Stick in the soffit and rub into place

Remove the release film strip on the membrane side (unprinted side) and gradually stick the tape in place on the soffit. Leave slack for expansion so as to allow for relative motion between components. Rub the tape firmly into place using the pro clima PRESSFIX application tool, for example.

→ Situation 2: Window has already been installed



Stick to the frame

Start the sticking procedure in the corner area of the frame. First position approx. 2 cm of the tape on the horizontal part of the frame and stick the adhesive strip to the frame. Guide the tape around the frame corner and stick the tape to the vertical part of the frame. Gradually remove the release film while doing so.



Stick to the soffit, allowing for slack

Remove the second (wide) release film strip and gradually stick the tape in place on the soffit. Start sticking the soffit in the corner area. Leave slack for expansion so as to allow for relative motion between components. Stick the tape into the next corner area.



Stick the corners

Apply the tape with an overlap of at least 2 cm in the corner areas.

Note

As an alternative for situation 2, please use CONTEGA SOLIDO SL.



CONTEGA[®] SL

Window sealing tape for interior use

For interior airtight joints at windows and doors on timber structures, with three adhesive strips.



Advantages

- ✓ Easy to work with: extra thin for easy folding in corner areas
- ✓ Independently confirmed suitability: tests in accordance with MO-01/1 passed at IFT in Rosenheim (DE)
- ✓ Reliable joints in combination with CONTEGA EXO for exterior use
- ✓ Fleece side can be plastered over: defined transition between window and/or vapour retarder and plaster
- ✓ Flexible application: three adhesive strips for use with timber, masonry or concrete structures
- ✓ Construction in adherence with standards: for airtight bonding in accordance with DIN 4108-7, SIA 180 and RT 2012
- ✓ Excellent values in the hazardous substance test, has been tested according to the ISO 16000 evaluation scheme

Technical data

| | | Substance |
|--|-------------------------------|--|
| Backing | | PP fleece and special PP copolymer membrane |
| Adhesive | | special acrylate adhesive |
| Attribute | Regulation | Value |
| Colour | | light blue |
| s _v -value (g-value Vapour permeance) | EN 1931 ASTM E 96 | 2.3 m (11.5 MNs/g 1.43 US perms) |
| Airtightness | ift, MO-01/1:2007-01, Sect. 5 | up to 1000 Pa, surrounding |
| Bonding requirement, non-aged/aged | DIN 4108-11 | passed |
| Can be plastered over | | yes |
| Application temperature | | above -10 °C; 14 °F |
| Temperature resistance | | permanent -40 °C to 90 °C ; -40 °F to 194 °F |
| Storage | | cool and dry |

Forms of delivery

Length: 30 m; Width: 85 und 120 mm

Substrates

Clean subsurfaces before sticking. Adhesion to frozen surfaces is not possible. There must be no water-repellent substances (e.g. grease or silicone) on materials to be bonded. The width of the adhesive tape that is to be plastered over should generally not exceed 60 mm (2 3/8") or 50 % of the soffit area. Detailed recommendations can be obtained from the relevant plaster producer. Subsurfaces must be sufficiently dry and stable. Permanent adhesion is achieved on all pro clima interior membranes and on other vapour retarder and airtight membranes (e.g. those made of PE, PA, PP and aluminium). Adhesion can be carried out on planed and painted wood, hard plastics, hard wood-based panels (chipboard, OSB and plywood panels). For bonding joints on masonry or concrete or on rough substrates, use ORCON F. The best results in terms of structural stability are achieved on high-quality subsurfaces. It is your responsibility to check the suitability of the subsurface; adhesion tests are recommended in certain cases. Pretreatment with TESCON PRIMER is recommended in the case of subsurfaces with insufficient stability.

General conditions

The bonds should not be subjected to tensile strain. Press firmly to secure the adhesive tapes in place. Ensure that there is sufficient resistance pressure. Airtight seals can only be achieved if the sealing tape is installed free of folds and breaks. Ventilate continuously and systematically to prevent build-up of excessive humidity; use a dryer if necessary. When plastering, please observe the recommendations of the plaster manufacturer for non-absorbent subsurfaces. A bonding course may be necessary. If the airtight connection is created straight after plastering, moisture ingress may occur in the thermal insulation or to problems in the order of construction.



Professur No. 14-001438-F102
[F9-E03-00010-06-003]
+ CONTEGA SL in ORCON F
+ CONTEGA EXO in ORCON F
mark 940-0131-2907-01, Abs. 9
26.02.2016





Installation instructions

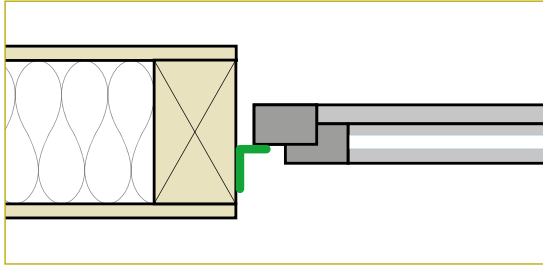

Timber frame construction after window installation

If the window has already been installed, CONTEGA SL is stuck to the frame.



Press the tape onto the soffit and frame to secure it. This work can be carried out more efficiently and in a manner that is kinder to your hands by using the pro clima PRESSFIX application tool.

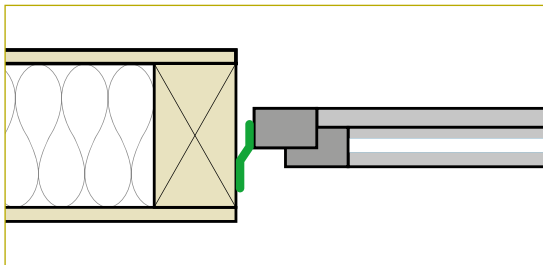

Timber frame construction before window installation

CONTEGA SL has already been installed to the side of the window – for example, by the window installation technician.



Remove the release film, fold the tape in the corner area and stick to one another. Stick the tape in place around the circumference of the soffit in an airtight manner. Press firmly to secure the tape in place.

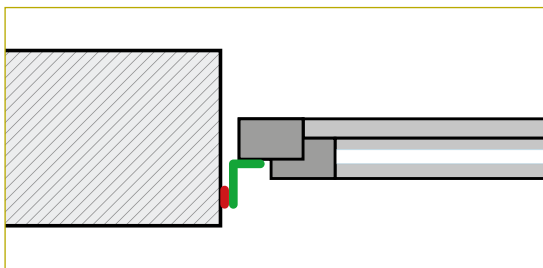

Masonry construction after window installation

If the window has already been installed, CONTEGA SL is stuck to the frame.



Position the tape on the frame and stick in place. Apply a line of ORCON F or ORCON CLASSIC joint adhesive around the circumference of the soffit in a tight zig-zag pattern. You're now ready for plastering!

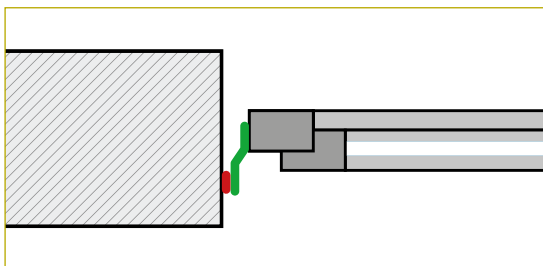

Masonry construction before window installation

CONTEGA SL has already been installed to the side of the window – for example, by the window installation technician.



Fold the tape together in the corner area. Apply ORCON F or ORCON CLASSIC to the soffit in a tight zig-zag pattern. Place the tape onto the adhesive. You're now ready for plastering!

Note

If the airtight joint is implemented after plastering, moisture entry into the thermal insulation or disruptions to the construction process may occur.

Engineering hotline

If your working conditions are different, please contact the pro clima Engineering Hotline **p. 65**

CONTEGA SOLIDO EXO

Exterior weather protection



CONTEGA[®] SOLIDO EXO

Full-surface adhesive plaster and window sealing tape for exterior use

For exterior windtight joints that are resistant to driving rain between windows or doors and adjacent building components made of wood or mineral substrates such as concrete and masonry, full-surface adhesion.

Advantages

- ✓ Saves time: the joint is immediately resistant to driving rain and can be subjected to loading
- ✓ Can be plastered over directly: defined transition between window and/or wind sealing and plaster
- ✓ Reliable joints: waterproof SOLID adhesive has extremely strong adhesion on mineral substrates too
- ✓ Independently confirmed suitability: tests in accordance with MO-01/1 passed at IFT in Rosenheim (DE)

Technical data

| | | Substance |
|---|-------------------------------|--|
| Backing | | PP backing fleece, PP copolymer special membrane |
| Adhesive | | modified waterproof SOLID adhesive |
| Release film | | one or two split silicone-coated PE sheet |
| Attribute | Regulation | Value |
| Colour | | black |
| s_d -value (g-value Vapour permeance) | EN 1931 ASTM E 96 | 0.7 m (3.5 MNs/g 4.7 US perms) |
| Exposure time | | 3 months |
| Water column | EN ISO 811 | > 2 500 mm ; > 8' 2" |
| Resistance to driving rain | ift, MO-01/1:2007-01, Sect. 5 | up to 600 Pa, surrounding |
| Bonding requirement, non-aged/aged | DIN 4108-11 | passed |
| Can be plastered over | | yes |
| Application temperature | | above -10 °C; 14 °F |
| Temperature resistance | | permanent -40 °C to 90 °C ; -40 °F to 194 °F |
| Storage | | cool and dry |

Forms of delivery

Length: 30 m; Width: 80, 100, 150 und 200 mm

Substrates

Clean substrates before sticking. Uneven mineral substrates may need to be levelled with a smooth finish. Adhesion to frozen surfaces is not possible. There must be no water-repellent substances (e.g. grease or silicone) on materials to be bonded. The width of the adhesive tape that is to be plastered over should generally not exceed 60 mm (2 3/8") or 50 % of the soffit area. Detailed recommendations can be obtained from the relevant plaster producer. Substrates must be sufficiently dry and stable. Permanent adhesion is achieved on all pro clima interior membranes and on other vapour retarder and airtight membranes (e.g. those made of PE, PA, PP and aluminium). Adhesion can be carried out on planed and painted wood, hard plastics, hard wood-based panels (chipboard, OSB and plywood panels) and on mineral substrates such as concrete and masonry. The best results in terms of structural stability are achieved on high-quality substrates. It is your responsibility to check the suitability of the substrate; adhesion tests are recommended in certain cases. Pretreatment with TESCON PRIMER is recommended in the case of substrates with insufficient stability.

General conditions

The bonds should not be subjected to tensile strain. Press firmly to secure the adhesive tapes in place. Ensure that there is sufficient resistance pressure. Seals that are windproof and resistant to driving rain can only be achieved if the sealing tape is installed free of folds and breaks. When plastering, please observe the recommendations of the plaster manufacturer for non-absorbent substrates. A bonding course may be necessary.



Installation instructions

→ Situation 1: Window has already been installed



Stick to the frame

Remove the narrow backing paper strip. Put the CONTEGA SOLIDO EXO in place using the full width of the adhesive strip and allowing for an excess of 2 cm beyond the corner of the frame. Stick the excess tape to the adjacent soffit side.



Stick to the soffit allowing for slack

Remove the backing paper strip and gradually stick the tape in place on the soffit. Leave slack for expansion so as to allow for relative motion between components. Stick the tape to the window sill.



Stick the corners and around the circumference of the window

Continue sticking the entire window (frame and soffit) in the same manner. Ensure that the corners are stuck over.

→ Situation 2: Before the window is installed



Stick to the side of the frame

Remove the narrow backing paper strip, position it on the side of the frame flush with the frame edge and then stick in place. The printed side of the tape facing up.



Corner finishing

To ensure that the tape can be simply and securely stuck to the window soffit later on, create corner folds as shown here and stick CONTEGA SOLIDO EXO around the circumference.



Stick to the soffit

Remove the backing paper strip and stick the tape in place around the circumference of the soffit.



CONTEGA® SOLIDO EXO-D

Full-surface adhesive plaster and window sealing tape for exterior use with an additional adhesive zone

For exterior windtight joints that are resistant to driving rain between windows or doors and adjacent building components made of wood or mineral substrates such as concrete and masonry, full-surface adhesion. The adhesive zone on the fleece side allows for easier adhesion to windows and doors if applied before they are installed.

Advantages

- ✓ The joint is immediately windproof and resistant to driving rain as a result of full-surface adhesion
- ✓ Extremely strong adhesion on mineral substrates too thanks to SOLID adhesive
- ✓ Can be plastered over
- ✓ Simple adhesion
- ✓ Easy to apply

Technical data

| | | Substance |
|---|-------------------------------|--|
| Backing | | PP backing fleece, PP copolymer special membrane |
| Adhesive | | modified waterproof SOLID adhesive |
| Release film | | one or two split silicone-coated PE sheet |
| Attribute | Regulation | Value |
| Colour | | black |
| s_d -value (g-value Vapour permeance) | EN 1931 ASTM E 96 | 0.7 m (3.5 MNs/g 4.7 US perms) |
| Exposure time | | 3 months |
| Water column | EN ISO 811 | > 2 500 mm; > 8' 2" |
| Resistance to driving rain | ift, MO-01/1:2007-01, Sect. 5 | up to 600 Pa, surrounding |
| Bonding requirement, non-aged/aged | DIN 4108-11 | passed |
| Can be plastered over | | yes |
| Application temperature | | above -10 °C; 14 °F |
| Temperature resistance | | permanent -40 °C to 90 °C; -40 °F to 194 °F |
| Storage | | cool and dry |

Forms of delivery

Length: 30 m; Width: 80 und 100 mm

Substrates

Clean substrates before sticking. Uneven mineral substrates may need to be levelled with a smooth finish. Adhesion to frozen surfaces is not possible. There must be no water-repellent substances (e.g. grease or silicone) on materials to be bonded. The width of the adhesive tape that is to be plastered over should generally not exceed 60 mm (2 3/8") or 50 % of the soffit area. Detailed recommendations can be obtained from the relevant plaster producer. Substrates must be sufficiently dry and stable. Permanent adhesion is achieved on all pro clima exterior membranes and on other underlay/sarking and wall lining membranes (e.g. those made of PP and PET). Adhesion can be carried out on planed and painted wood, hard plastics, hard wood-based panels (chipboard, OSB and plywood panels) and on mineral substrates such as concrete and masonry. The best results in terms of structural stability are achieved on high-quality substrates. It is your responsibility to check the suitability of the substrate; adhesion tests are recommended in certain cases. Pretreatment with TESCON PRIMER is recommended in the case of substrates with insufficient stability.

General conditions

The bonds should not be subjected to tensile strain. Press firmly to secure the adhesive tapes in place. Ensure that there is sufficient resistance pressure. Seals that are windproof and resistant to driving rain can only be achieved if the sealing tape is installed free of folds and breaks. When plastering, please observe the recommendations of the plaster manufacturer for non-absorbent substrates. A bonding course may be necessary.



Installation instructions

→ Situation 1: Before the window is installed



Stick to the side of the frame

Remove the single release film strip on the printed side, position it on the side of the frame and then gradually stick in place. The printed side of the tape must be facing the window (upwards) here.



Corner finishing

Allow CONTEGA SOLIDO EXO-D to protrude by about 2 cm in the corner area (length of the corner diagonal of the joint) and stick it in the form of a corner fold.



Stick CONTEGA SOLIDO EXO-D in the soffit and rub into place

Remove the release film strip on the membrane side (unprinted side) and gradually stick the tape in place on the soffit. Leave slack for expansion so as to allow for relative motion between components. Rub the tape firmly into place using the pro clima PRESSFIX application tool, for example. Creating a window sill (EXTOSEAL ENCORS).

→ Situation 2: Window has already been installed



Stick to the frame

Remove approx. 5-10 cm of the narrow release film strip on the membrane side (unprinted side). Guide the tape around the frame corner and stick the tape to the vertical part of the frame.



Stick to the soffit, allowing for slack

Remove the second (wide) release film strip and gradually stick the tape in place on the soffit. Start sticking the soffit in the corner area. Leave slack for expansion so as to allow for relative motion between components.



Stick the corners and around the circumference of the window

Continue sticking the rest of the window (frame and soffit) in the same manner. Ensure that the corners are stuck over with at least 2 cm of an overlap. The adhesive bond must be windtight and resistant to driving rain all around.

Note

As an alternative for situation 2, please use CONTEGA SOLIDO EXO.

CONTEGA EXO

Exterior weather protection



CONTEGA[®] EXO

Window sealing tape for exterior use

For exterior windtight joints that are resistant to driving rain between windows or doors and adjacent building components, with three adhesive strips.

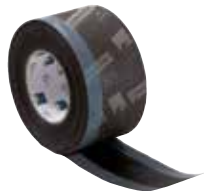

Advantages

- ✓ Easy to work with: extra thin for easy folding in corner areas
- ✓ Independently confirmed suitability: tests in accordance with MO-01/1 passed at IFT in Rosenheim (DE)
- ✓ Reliable joints in combination with CONTEGA SL for interior use
- ✓ Fleece side can be plastered over: defined transition between window or wind sealing and plaster
- ✓ Flexible application: three adhesive strips for use with timber, masonry or concrete structures

Technical data

| | | Substance |
|--|-------------------------------|--|
| Backing | | double-layer special membrane made of PP fleece and TEEE functional film |
| Adhesive | | special acrylate adhesive |
| Attribute | Regulation | Value |
| Colour | | dark grey |
| s _a -value (g-value Vapour permeance) | EN ISO 12572 ASTM E 96 | 0.05 m (0.25 MNs/g 65.6 US perms) |
| Exposure time | | 3 months |
| Water column | EN ISO 811 | > 2 500 mm; > 8' 2" |
| Resistance to driving rain | ift, MO-01/1:2007-01, Sect. 5 | up to 600 Pa, surrounding |
| Bonding requirement, non-aged/aged | DIN 4108-11 | passed |
| Can be plastered over | | yes |
| Application temperature | | above -10 °C; 14 °F |
| Temperature resistance | | permanent -40 °C to 90 °C; -40 °F to 194 °F |
| Storage | | cool and dry |

Forms of delivery

Length: 30 m; Width: 85 und 120 mm

Substrates

Clean substrates before sticking. Adhesion to frozen surfaces is not possible. There must be no water-repellent substances (e.g. grease or silicone) on materials to be bonded. The width of the adhesive tape that is to be plastered over should generally not exceed 60 mm (2 3/8") or 50 % of the soffit area. Detailed recommendations can be obtained from the relevant plaster producer. Subsurfaces must be sufficiently dry and stable. Permanent adhesion is achieved on all pro clima exterior membranes and on other underlay/sarking and wall lining membranes (e.g. those made of PP and PET). Adhesion can be carried out on planed and painted wood, hard plastics, hard wood-based panels (chipboard, OSB and plywood panels). For bonding joints on masonry or concrete or on rough substrates, use ORCON F. The best results in terms of structural stability are achieved on high-quality substrates. It is your responsibility to check the suitability of the subsurface; adhesion tests are recommended in certain cases. Pretreatment with TESCON PRIMER is recommended in the case of substrates with insufficient stability.

General conditions

The bonds should not be subjected to tensile strain. Press firmly to secure the adhesive tapes in place. Ensure that there is sufficient resistance pressure. Seals that are windproof and resistant to driving rain can only be achieved if the sealing tape is installed free of folds and breaks. When plastering, please observe the recommendations of the plaster manufacturer for non-absorbent substrates. A bonding course may be necessary.



Profitechnik No. 14-001438-PRO
 (FR-003-020310-06-003)
 + CONTEGA SL BY ORCON F.
 + CONTEGA EXO BY ORCON F.
 mark MO-01/1:2007-01, Abs. 5
 26.02.2016



Installation instructions

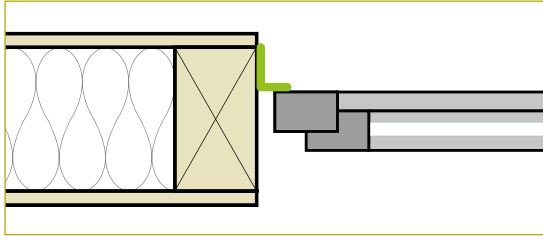

Timber frame construction after window installation

If the window has already been installed, CONTEGA EXO is stuck to the frame.



Press the CONTEGA EXO onto the soffit and frame to secure it. This work can be carried out more efficiently and in a manner that is kinder to your hands by using the pro clima PRESSFIX application tool.

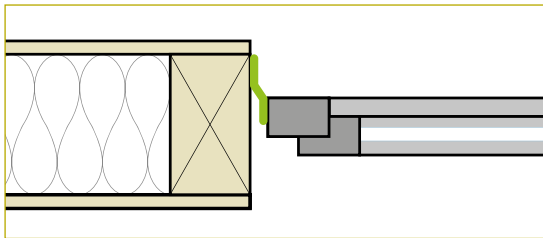

Timber frame construction before window installation

CONTEGA EXO has already been installed to the side of the window – for example, by the window installation.



Remove the release film, fold the tape in the corner area and stick to one another. Stick the tape in place around the circumference of the soffit in a manner that is windtight and resistant to driving rain. Press firmly to secure the tape in place.

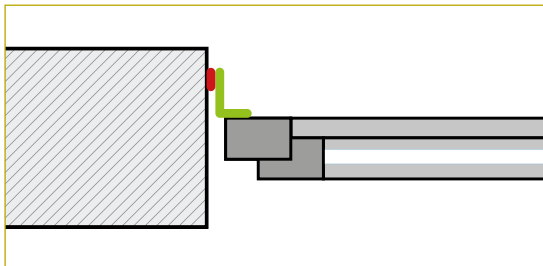

Masonry construction after window installation

If the window has already been installed, CONTEGA EXO is stuck to the frame.



Position the tape on the frame and stick in place. Apply a line of ORCON F or ORCON CLASSIC joint adhesive around the circumference of the soffit in a tight zig-zag pattern. You're now ready for plastering!

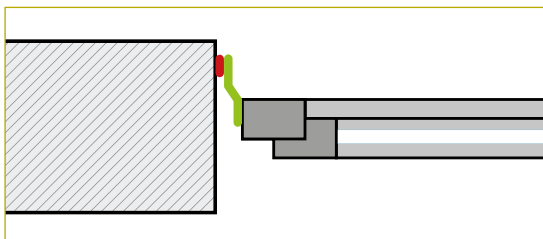

Masonry construction before window installation

CONTEGA EXO has already been installed to the side of the window – for example, by the window installation technician.



Fold the tape together in the corner area. Apply ORCON F or ORCON CLASSIC to the soffit in a tight zig-zag pattern. Place the tape onto the adhesive. You're now ready for plastering!

Engineering hotline

If your working conditions are different, please contact the pro clima Engineering Hotline p. 65

Note on installation

Installation film (in german)
CONTEGA EXO:



CONTEGA SOLIDO IQ

Interior air sealing

Exterior weather protection



CONTEGA® SOLIDO IQ

Intelligent full-surface adhesive window sealing tape for interior and exterior use

For interior airtight joints between windows or doors and vapour retarder and airtight layers. Thanks to its intelligent, humidity-variable functional membrane, CONTEGA SOLIDO IQ is also suitable for exterior windproof and rainproof joints.

Advantages

- ✓ Reliable installation: the same tape for interior and exterior use thanks to its intelligent functional membrane
- ✓ Saves time: the joint is immediately windproof and resistant to driving rain, and it can be subjected to loading
- ✓ Reliable joints: waterproof SOLID adhesive has extremely strong adhesion on mineral substrates too
- ✓ Extra thin: for easy folding in corner areas
- ✓ Construction in adherence with standards: for airtight bonding in accordance with DIN 4108-7, SIA 180 and RT 2012
- ✓ Fleece side can be plastered over: defined transition between window joints and plaster
- ✓ Excellent values in the hazardous substance test, has been tested according to the ISO 16000 evaluation scheme

NEW

Technische Daten

| | | Substance |
|--|--------------|--|
| Backing | | PP backing fleece, PE copolymer special membrane |
| Adhesive | | modified waterproof SOLID adhesive |
| Release film | | one or two split silicone-coated PE sheet |
| Attribute | Regulation | Value |
| Colour | | white, print: green |
| s_d -value (g-value) humidity variable | EN ISO 12572 | 0.4 - > 25 m (2 - > 125 MN s/g) |
| Vapour permeance humidity variable | ASTM E 96 | < 0.13 - 8 US perms |
| Exposure time | | 3 months |
| Water column | EN ISO 811 | > 2.500 m |
| Can be plastered over | | yes |
| Application temperature | | above -10 °C ; 14 °F |
| Temperature resistance | | permanent -40 °C to 90 °C ; -40 °F to 194 °F |
| Storage | | cool and dry |

Schematic sketch

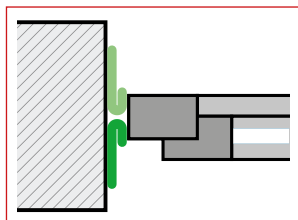

Forms of delivery

Length: 30 m; Width: 80, 100, 150, 200 mm

Substrates

Clean substrates before sticking. Uneven mineral substrates may need to be levelled with a smooth finish. Adhesion to frozen surfaces is not possible. There must be no water-repellent substances (e.g. grease or silicone) on materials to be bonded. The width of the adhesive tape that is to be plastered over should generally not exceed 60 mm (2 3/8") or 50 % of the soffit area. Detailed recommendations can be obtained from the relevant plaster producer. Substrates must be sufficiently dry and stable. Permanent adhesion is achieved on all pro clima interior and exterior membranes, other vapour retarder and airtight membranes (e.g. those made of PE, PA, PP and aluminium) as well as other underlay/sarking and wall lining membranes (e.g. those made of PP and PET). Adhesion can be carried out on planed and painted wood, hard plastics, hard wood-based panels (chipboard, OSB and plywood panels) and on mineral substrates such as concrete and masonry. The best results in terms of structural stability are achieved on high-quality substrates. It is your responsibility to check the suitability of the substrate; adhesion tests are recommended in certain cases. Pretreatment with TESCON PRIMER is recommended in the case of substrates with insufficient stability.

General conditions

The bonds should not be subjected to tensile strain. Press firmly to secure the adhesive tapes in place. Ensure that there is sufficient resistance pressure. Driving rainproof and wind- or airtight seals can only be achieved if this connection tape is laid without folds or creases and are uninterrupted. Ventilate continuously and systematically to prevent build-up of excessive humidity; use a dryer if necessary. When plastering, please observe the recommendations of the plaster manufacturer for non-absorbent substrates. A bonding course may be necessary.



→ Situation 1: Before the window is installed



1

Stick to the side of the frame

Remove the narrow release film strip, position it on the side of the frame flush with the frame edge and then stick in place. Stick the tapes to the inside and outside of the windows. NOTE: Ensure that the overlap is water-proof when sticking to the exterior



2

Stick in the soffit and rub into place

Remove the release film strip and stick the tape all around the window.

→ Situation 2: Window has already been installed



1

Cut tape to length

Add approx. 6 - 8 cm (2.5" - 3 1/8") to the width of the underside of the frame and cut this length of CONTEGA SOLIDO IQ. First position approx. 2 cm (7/8") of the tape on the vertical part of the frame and stick the adhesive strip to the frame.



2

Stick to the soffit

Gradually remove the second (wide) release film strip. Start sticking to the soffit in the corner area. Stick the excess tape to the adjacent soffit side. Stick the tape as far as the next corner area. Stick the excess tape to the adjacent soffit side.

→ Other situations



Joints between membrane and masonry wall

Put the vapour retarder in position. Leave slack for expansion so as to allow for relative motion between components. Remove all backing papers from CONTEGA SOLIDO IQ. Put the tape in place, gradually stick it. Rub tape firmly into place using the pro clima PRESSFIX.



Angular penetrations in masonry / concrete

Remove the narrow backing paper and stick the tape to the first side of the beam. Remove the wide backing paper and stick the tape to the wall. Cut into the tape at the beam corners so that the tape can be stuck to the adjacent beam side. Bond the other sides analogously in an airtight manner. Rub tape firmly into place using the pro clima PRESSFIX.

CONTEGA SOLIDO SL-D

Interior air sealing

Exterior weather protection



CONTEGA[®] SOLIDO IQ-D

Intelligent full-surface adhesive window sealing tape for interior and exterior use with additional adhesive zone

For interior airtight joints between windows or doors and vapour retarder and airtight layers. Thanks to its intelligent, humidity-variable functional membrane, CONTEGA SOLIDO IQ-D is also suitable for exterior windproof and rainproof joints. The adhesive zone on the fleece side allows for easier adhesion to windows and doors if applied before they are installed.



NEW

Advantages

- ✓ Reliable installation: the same tape for interior and exterior use thanks to its intelligent functional membrane
- ✓ Saves time: the joint is immediately windproof and resistant to driving rain, and it can be subjected to loading
- ✓ Reliable joints: waterproof SOLID adhesive has extremely strong adhesion on mineral substrates too
- ✓ Simple joints thanks to the additional adhesive zone
- ✓ Extra thin: for easy folding in corner areas
- ✓ Construction in adherence with standards: for airtight bonding in accordance with DIN 4108-7, SIA 180 and RT 2012
- ✓ Fleece side can be plastered over: defined transition between window joints and plaster
- ✓ Excellent values in the hazardous substance test, has been tested according to the ISO 16000 evaluation scheme

Technische Daten

| | | Substance |
|--|--------------|--|
| Backing | | PP backing fleece, PE copolymer special membrane |
| Adhesive | | modified waterproof SOLID adhesive |
| Release film | | one or two split silicone-coated PE sheet |
| Attribute | Regulation | Value |
| Colour | | |
| | | white, print: green |
| s_d -value (g-value) humidity variable | EN ISO 12572 | 0.4 - > 25 m (2 - > 125 MN s/g) |
| Vapour permeance humidity variable | ASTM E 96 | 8.20 - < 0.13 US perms |
| Exposure time | | 3 months |
| Water column | EN ISO 811 | > 2 500 mm |
| Can be plastered over | | yes |
| Application temperature | | above -10 °C; 14 °F |
| Temperature resistance | | permanent -40 °C to 90 °C ; -40 °F to 194 °F |
| Storage | | cool and dry |

Schematic sketch

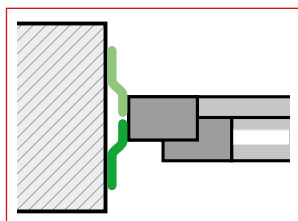

Forms of delivery

Length: 30 m; Width: 80, 100, 150 mm

Substrates

Clean substrates before sticking. Uneven mineral substrates may need to be levelled with a smooth finish. Adhesion to frozen surfaces is not possible. There must be no water-repellent substances (e.g. grease or silicone) on materials to be bonded. The width of the adhesive tape that is to be plastered over should generally not exceed 60 mm (2 3/8") or 50 % of the soffit area. Detailed recommendations can be obtained from the relevant plaster producer. Substrates must be sufficiently dry and stable. Permanent adhesion is achieved on all pro clima interior and exterior membranes, other vapour retarder and airtight membranes (e.g. those made of PE, PA, PP and aluminium) as well as other underlay/sarking and wall lining membranes (e.g. those made of PP and PET). Adhesion can be carried out on planed and painted wood, hard plastics, hard wood-based panels (chipboard, OSB and plywood panels) and on mineral substrates such as concrete and masonry. The best results in terms of structural stability are achieved on high-quality substrates. It is your responsibility to check the suitability of the substrate; adhesion tests are recommended in certain cases. Pretreatment with TESCON PRIMER is recommended in the case of substrates with insufficient stability.

General conditions

The bonds should not be subjected to tensile strain. Press firmly to secure the adhesive tapes in place. Ensure that there is sufficient resistance pressure. Driving rainproof and wind- or airtight seals can only be achieved if this



connection tape is laid without folds or creases and are uninterrupted. Ventilate continuously and systematically to prevent build-up of excessive humidity; use a dryer if necessary. When plastering, please observe the recommendations of the plaster manufacturer for non-absorbent substraces. A bonding course may be necessary.



1 Stick to the side of the frame

Remove the narrow release film strip, position it on the side of the frame flush with the frame edge and then stick in place. Stick the tapes to the inside and outside of the windows. NOTE: Ensure that the overlap is waterproof when sticking to the exterior!



2 Corner finishing

To ensure that the tape can be simply and securely stuck to the window soffit later on, create corner folds as shown here and stick CONTEGA SOLIDO IQ-D around the circumference. The length of the overlap must be around 1.5 times the width of the gap in order to avoid unnecessary folds.



3 Cut and stick in place

When finished, cut the tape with approx. 5 cm of an overlap. Stick the ends to each other on the frame.



4 Stick in the soffit and rub into place

Remove the release film strip and stick the tape all around the window.



5 Rub into place

Rub the tape around the circumference using the pro clima PRESSFIX application tool to secure it.



6 You're finished!

The joint, which is either airtight or resistant to driving rain, is now complete, and the tape can be plastered over.

CONTEGA IQ

Interior air sealing

Exterior weather protection



CONTEGA® IQ

Intelligent window sealing tape for interior and exterior use



For interior airtight joints between windows or doors and the vapour retarder and airtight layer. Thanks to its intelligent, humidity-variable functional membrane, CONTEGA IQ is also suitable for exterior windproof and rainproof joints.

Advantages

- ✓ Reliable installation: the same tape for interior and exterior use thanks to its intelligent functional membrane
- ✓ Extra thin: for easy folding in corner areas
- ✓ Construction in adherence with standards: for airtight bonding in accordance with DIN 4108-7, SIA 180 and RT 2012
- ✓ Reliable performance independently confirmed: bears the RAL quality mark
- ✓ Reliable joints: slack for expansion can accommodate movements by building components
- ✓ Fleece side can be plastered over: defined transition between window joints and plaster
- ✓ Excellent values in the hazardous substance test, has been tested according to the ISO 16000 evaluation scheme

For masonry construction
with 1 self-adhesive strip

For timber construction
with 2 self-adhesive strips



Technical data

| | | Substance |
|--|---|---|
| Backing | | PP fleece and special PP copolymer membrane |
| Adhesive | | special acrylate adhesive |
| Attribute | Regulation | Value |
| Colour | | dark blue |
| s_d -value (g-value) humidity variable | EN ISO 12572 | 0.25 - 10 m (1.25 - 50 MNs/g) |
| Vapour permeance humidity variable | ASTM E 96 | 0.33 - 13 US perms |
| Exposure time | | 3 months |
| Bonding requirement, non-aged/aged | DIN 4108-11 | passed |
| Can be plastered over | | yes |
| RAL quality label | RAL-GZ 711, Fugendichtungs- komponenten und -systeme | available |
| Application temperature | | above -10 °C; 14 °F |
| Temperature resistance | | permanent -40 °C to 90 °C; -40 °F to 194 °F |
| Storage | | cool and dry |

Forms of delivery

Art. no. 12941 – Length: 30 m; Width: 90 mm, 1 self-adhesive strip (for masonry construction)

Art. no. 13016 – Length: 30 m; Width: 90 mm, 2 self-adhesive strips (for timber construction)

Substrates

Clean substrates before sticking. Adhesion to frozen surfaces is not possible. There must be no water-repellent substances (e.g. grease or silicone) on materials to be bonded. The width of the adhesive tape that is to be plastered over should generally not exceed 60 mm (2 3/8") or 50 % of the soffit area. Detailed recommendations can be obtained from the relevant plaster producer. Subsurfaces must be sufficiently dry and stable. Permanent adhesion is achieved on all pro clima interior and exterior membranes, other vapour retarder and airtight membranes (e.g. those made of PE, PA, PP and aluminium) as well as other underlay/sarking and wall lining membranes (e.g. those made of PP and PET). Adhesion can be carried out on planed and painted wood, hard plastics, hard wood-based panels (chipboard, OSB and plywood panels). For bonding joints on masonry or concrete or on rough substrates, use ORCON F. The best results in terms of structural stability are achieved on high-quality substrates. It is your responsibility to check the suitability of the substrate; adhesion tests are recommended in certain cases. Pretreatment with TESCON PRIMER is recommended in the case of substrates with insufficient stability.

General conditions

The bonds should not be subjected to tensile strain. Press firmly to secure the adhesive tapes in place. Ensure that there is sufficient resistance pressure. Driving rainproof and wind- or airtight seals can only be achieved if this connection tape is laid without folds or creases and are uninterrupted. Ventilate continuously and systematically to prevent build-up of excessive humidity; use a dryer if necessary. When plastering, please observe the recommendations of the plaster manufacturer for non-absorbent substrates. A bonding course may be necessary.





Installation instructions

→ **Timber construction: interior and exterior**

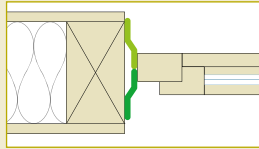

1
Stick the tape to the frame

Before the window is installed, stick CONTEGA IQ onto the side of the window frame with the non-printed side facing the soffit. Press firmly to secure the tape in place.



2
Corner finishing

To ensure that the tape can be simply and securely stuck to the window soffit later on, create corner folds as shown here.



3
Stick the ends

To ensure proper airtightness and/or wind sealing, stick the start and end of the CONTEGA IQ tape to each other using a strip of DUPLEX.



interior



exterior

4
Stick the tape in place around the circumference of the soffit

Install the window into the soffit, then remove the release film from CONTEGA IQ and stick the tape in place around the circumference of the soffit in an airtight and/or windtight manner. Press firmly to secure the tape in place. Ensure that the corners created are airtight and/or windtight.

→ **Masonry construction: interior and exterior**

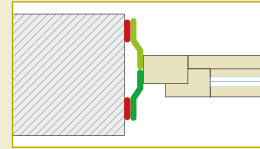

1
Stick the tape to the frame

Before the window is installed, stick CONTEGA IQ onto the side of the window frame with the non-printed side facing the soffit. Press firmly to secure the tape in place.



2
Corner finishing

To ensure that the tape can be simply and securely stuck to the window soffit later on, create corner folds as shown here.



3
Stick the ends

To ensure proper airtightness and/or wind sealing, stick the start and end of the CONTEGA IQ tape to each other using a strip of DUPLEX.



interior



exterior

4
Stick the tape in place around the circumference of the soffit

Install the window into the soffit, apply an approx. 5 mm thick line of ORCON F or ORCON CLASSIC joint adhesive around the circumference of the soffit in a tight zig-zag pattern, and then place the tape onto the adhesive in an airtight and/or windtight manner. Ensure that the corners created are airtight and/or windtight.

Note

The slack included for expansion automatically becomes active if there is relative motion between building components and provides increased protection against tearing. CONTEGA IQ thus provides optimal protection against leaks that could lead to damage to structures and mould.



Engineering hotline

If your working conditions are different, please contact the pro clima Engineering Hotline p. 65

CONTEGA FIDEN EXO

Exterior weather protection



CONTEGA® FIDEN EXO

Pre-compressed joint sealing tape for exterior use

For exterior sealing of joints on building structures in a manner that is open to diffusion and resistant to driving rain on building structures.

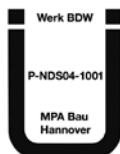

Nur schwarz entflammbar
(DIN 4102-B1) zwischen
massiven, mineralischen
Baustoffen.

Advantages

- ✓ Permanent joint sealing thanks to extremely high resistance to weathering
- ✓ Fulfils the highest requirements: BG1 quality
- ✓ Ensures dry building components: resistant to driving rain and open to diffusion
- ✓ RAL quality-tested installation
- ✓ Large range for all standard joint widths

Technical data

| | | Substance |
|--|------------|--|
| Material | | open-cell polyurethane flexible foam with polymer impregnation |
| Attribute | Regulation | Value |
| Colour | | anthracite |
| s_d -value (g-value Vapour permeance) | ASTM E 96 | < 0.5 m (< 2.5 MNs/g > 6.56 US perms) |
| Fire rating | DIN 4102 | B1, P-NDS04-1001 |
| Joint permeability | EN 1026 | $a < 0.1 \text{ m}^3/[(\text{h}\cdot\text{m}\cdot(\text{daPa})^n]$ |
| Loading group | DIN 18542 | BG1 |
| Resistance to driving rain | EN 1027 | requirements fulfilled up to 600 Pa |
| Weather resistance | DIN 18542 | passed |
| Can be plastered/painted over | | yes |
| Compatibility with conventional construction materials | DIN 18542 | yes |
| Application temperature | | above +1 °C; 34 °F |
| Temperature resistance | | permanent: -30 °C to +90 °C; -22 °F to 194 °F |
| Storage | | 1 °C to 20 °C; 34 °F to 68 °F, 12 months, cool and dry |

Forms of delivery

- Art. no. 15547 – Length: 10 m; Width: 10 mm; Joint: 2–3 mm
- Art. no. 15548 – Length: 10 m; Width: 15 mm; Joint: 2–3 mm
- Art. no. 15549 – Length: 8 m; Width: 12 mm; Joint: 3–6 mm
- Art. no. 15550 – Length: 8 m; Width: 15 mm; Joint: 3–6 mm
- Art. no. 15552 – Length: 5 m; Width: 15 mm; Joint: 5–10 mm
- Art. no. 15553 – Length: 5 m; Width: 20 mm; Joint: 5–10 mm
- Art. no. 15554 – Length: 4,3 m; Width: 15 mm; Joint: 7–12 mm
- Art. no. 15555 – Length: 4,3 m; Width: 20 mm; Joint: 7–12 mm
- Art. no. 15556 – Length: 3,3 m; Width: 20 mm; Joint: 8–15 mm
- Art. no. 15557 – Length: 2,6 m; Width: 20 mm; Joint: 10–18 mm

Substrates

Clean any loose dust and dirt from the joint. The masonry may need to be levelled with a smooth finish (e.g. mortar joints). Clean the sides of the window frames. Adhesion to frozen surfaces is not possible. There must be no water-repellent substances (e.g. grease or silicone) on materials to be bonded. Subsurfaces must be sufficiently dry and stable. Permanent adhesion is achieved on planed and painted wood, hard plastics, hard wood-based panels (chipboard, OSB, plywood panels) and metal. The best results in terms of structural stability are achieved on high-quality subsurfaces. It is your responsibility to check the suitability of the subsurface; adhesion tests are recommended in certain cases.



Installation instructions

General conditions

The tape must be stored in a cool place on the building site when temperatures are above 20 °C (68 °F). When temperatures are below 8 °C (47 °F), the tape should ideally be kept above this temperature. Select the tape dimensions and planning of the joint dimension according to the RAL guideline for planning and carrying out the installation of windows and doors. Allow 1 cm (3/8") of additional length of the tape for every metre length of the joint (compressed installation). Use butt-joints at corners and longitudinal joints. Ensure the tape remains in place until decompressed by using the self-adhesive surface on a suitable subsurface. Fit the tape with an offset of at least 2 mm (1/16") inside the edge of the joint for engineering reasons. To avoid decompression of already-started rolls: fix the ends of the tape with a staple or else wrap an adhesive strip fully around the tape. Store the rolls lying flat. Place a weight on the side of already-started rolls. Check compatibility before plastering or painting over the tape. Do not bring the tape into contact with aggressive chemicals or clean it using aggressive chemicals.



1 Remove the protective sheet

Cut the outer protective sheet with a utility knife and remove this sheet.



2 Cut off the start of the tape

Roll off some of the CONTEGA FIDEN EXO and cut off the overcompressed start of the tape (approx. 2 cm).



3 Stick the tape to the frame

Remove the backing paper, align the tape straight on the frame and gradually stick in place. The tape must not be visible after installation (recess approx. 1 - 2 mm).



4 Allow for slack in the tape

Allow for a small amount of slack in the tape when sticking it in place, particularly near joints – do not stretch the tape!



5 Use butt-joints at corners

Stick the tape around the circumference of the frame. Use one length of CONTEGA FIDEN EXO per side here and use butt-joints at the corners. Allow for a small amount of slack near the corners.



6 Install the window

Install the window professionally using a suitable fastening system.

Note

KLIPFIX: Makes it easy to close off a roll of joint-sealing tape that has already been started CONTEGA FIDEN EXO. [p. 43](#)

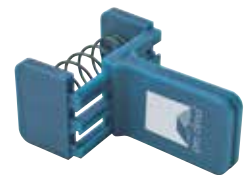

AEROSANA VISCONN

Interior air sealing

Exterior weather protection



Spraying instead of sticking: Quick and easy airtightness

AEROSANA[®] VISCONN

For use as a humidity-variable vapour retarder and airtight layer that can be applied as a spray or using a brush on wall, ceiling and floor surfaces, such as non-plastered masonry or porous panel-form materials.

- Also for the creation of joints to components such as windows, roofs, walls, ceilings and floors.
- Can also be used for strengthening subsurfaces in the case of renovation.
- The humidity-variable diffusion resistance of this product means that it can be used on the interior and exterior of building components.
- Forms a seamless, elastic air-retarding and vapour-retarding protective layer once it has dried.

Advantages

- ✓ Simply spray it on: extremely quick application
- ✓ Particularly on transitions and detail features with lots of edges and corners
- ✓ Reliable in the case of relative motion between building components: remains permanently elastic
- ✓ Sticks to all standard construction surfaces, can also be used as a bonding course
- ✓ Can be plastered, painted and stuck over
- ✓ Covers cracks and joints of up to 20mm width (AEROSANA VISCONN FIBRE)
- ✓ No mixing necessary: ready-to-use, apply straight from the bucket



Joints with windows, including second waterproof layers/sub-sill flashing

Creation of airtight interior joints and exterior joints that are resistant to driving rain, using either a painting or spraying procedure. Can be used flexibly on fibrous insulation materials (e.g. hemp wool or sheep wool) and on spray foam. Interior and exterior joints tested and confirmed in accordance with the IFT Guideline MO-01/1:2007-01, Section 5.



NEW



AEROSANA VISCONN



Professur No. 18-004115-7801
 (PB 1-603-02010-00-02)
 - AEROSANA VISCONN
 nach MBO-01/1:2007-01, Abs. 6
 21.06.2019





Spray-on airtightness system

AEROSANA VISCONN/AEROSANA VISCONN white

Sprayable airtightness sealant with a humidity-variable s_d value

| Substance | |
|------------------------------------|--|
| Material | modified aqueous acrylate polymer dispersion |
| Attribute | Value |
| Colour AEROSANA VISCONN | dark blue, when fully dry dark blue/black |
| Colour AEROSANA VISCONN white | white, when fully dry white |
| Coating application | 0.2 - 1.0 mm; 8 - 39 mils - wet film |
| s_d -value/humidity variable | 6 m (at 0.3 mm thickness) / 0.13 - 10.00 m |
| g-value/humidity variable | 30 MN-s/g (at 0.3 mm thickness) / 0.65 - 50 MN-s/g |
| Vapour permeance/humidity variable | 0.55 US perms (at 0.3 mm ; 12 mils thickness) / 0.33 - 25 US perms |
| Can be plastered/painted over | yes, and pro clima adhesive tapes can be stuck onto it |
| Application temperature | 5 °C to 60 °C; 40 °F to 140 °F |
| Temperature resistance | permanent -40 °C to 90 °C ; -40 °F to 194 °F (dried) |
| Ergiebigkeit | ca. 750 g/m ² , je nach Auftragsdicke und Untergrund |
| Durability | permanent |



AEROSANA VISCONN / white
Sprayable airtightness sealant
with a humidity-variable s_d value
(g value, permeance)

NEW

AEROSANA VISCONN FIBRE

Fibre-reinforced brush-on sealant with a humidity-variable s_d value (g value, permeance)

| Substance | |
|------------------------------------|---|
| Material | modified aqueous acrylate polymer dispersion, fibre-reinforced |
| Attribute | Value |
| Colour | dark blue, when fully dry black |
| Coating application | 0.6 - 1.4 mm; 24 - 55 mils - wet film |
| s_d -value/humidity variable | 3.5 m (at 0.3 mm thickness) / 0.15 - 5.00 m |
| g-value/humidity variable | 17.5 MN-s/g (at 0.3 mm thickness) / 0.75 - 25 MN-s/g |
| Vapour permeance/humidity variable | 0.94 US perms (at 0.3 mm thickness) / 0.66 - 22 US perms |
| Can be plastered/painted over | yes, and pro clima adhesive tapes can be stuck onto it |
| Application temperature | 5 °C to 60 °C; 41 °F to 140 °F |
| Temperature resistance | permanent -40 °C to 90 °C; -40 °F to 194 °F (dried) |
| Coverage | 400-800 g/m ² ; 1.3-2.6 oz/ft ² , depending on subsurface and applied thickness |
| Durability | permanent |



AEROSANA VISCONN FIBRE
Fibre-reinforced brush-on sealant
with a humidity-variable s_d value
(g value, permeance)

NEW

AEROSANA FLEECE

Fleece for covering cracks or joints within the AEROSANA VISCONN system

| Substance | |
|------------------------|---|
| Material | PET |
| Attribute | Value |
| Surface weight | 63 g/m ² ; 0,21 oz/ft ² |
| Thickness | 0,7 mm ; 28 mils |
| Tensile strength MD/CD | 90 N/5 cm / 145 N/5 cm; 10 lb/in / 17 lb/in |
| Elongation MD/CD | 75 % / 90 % |



AEROSANA FLEECE
Seals holes of up to a maximum of
70 mm in diameter and joints (e.g.
for roof refurbishment from the outside)
within the AEROSANA VISCONN system

NEW

Forms of delivery

AEROSANA VISCONN, AEROSANA VISCONN white – content: 10 liter

AEROSANA VISCONN FIBRE – content: 5 liter

AEROSANA FLEECE – length: 25 m; width: 150 mm



ORCON® F

All-round joint adhesive for interior and exterior use

Permanent, elastic joint adhesive. For bonding all types of vapour retarders and vapour barriers, e.g. pro clima INTELLO, PE, PA, PP and aluminium sheeting, and underlay and wall lining membranes to adjacent building components.

Advantages

- ✓ Reliable adhesion even during frosty conditions: can be worked with above -10 °C
- ✓ Ensures firm and permanently elastic adhesion
- ✓ Ensures reliable joints: penetrates deep into the subsurface, remains elastic
- ✓ Test winner in April 2012 with the German product-testing foundation 'Stiftung Warentest'
- ✓ Construction in adherence with standards: for airtight bonding in accordance with DIN 4108-7, SIA 180 and RT 2012
- ✓ Can be stored down to -20 °C . Material does not freeze in the tube
- ✓ Excellent values in the hazardous substance test, has been tested according to the ISO 16000 evaluation scheme

Technical data

| Substance | |
|------------------------------------|---|
| Material | Dispersion based on acrylic acid copolymers and ethanol. Free from plasticisers, halogens |
| Attribute | Value |
| Colour | green |
| Properties | very tensile |
| Bonding requirement, non-aged/aged | passed |
| Application temperature | -10 °C to 50 °C ; 14 °F to 122 °F |
| Temperature resistance | permanent -40 °C to 80 °C ; -40 °F to 176 °F |
| Storage | up to -20 °C ; -4 °F , cool and dry |

Forms of delivery

Cartridge 310 ml, Coverage: 5 mm Bead $\sim 15\text{ m}$; 8 mm Bead $\sim 6\text{ m}$

Foil tube 600 ml, Coverage: 5 mm Bead $\sim 30\text{ m}$; 8 mm Bead $\sim 12\text{ m}$

Substrates

Clean subsurfaces before sticking. Mineral surfaces (plaster or concrete) may be slightly moist. Adhesion to frozen surfaces is not possible. The substrate material must be free of water-repellent substances (e.g. grease or silicone). Subsurfaces must be stable - if necessary, a mechanical support (pressure lath) must be used (e.g. on crumbling subsurfaces). Permanent adhesion is achieved on all pro clima interior and exterior membranes, other vapour retarder and airtight membranes (e.g. those made of PE, PA, PP and aluminium) as well as other underlay/sarking and wall lining membranes (e.g. those made of PP and PET). Bonds can be created on mineral subsurfaces (e.g. plaster or concrete), roughly sawn and planed wood same as hard wood-based panels (chipboard, OSB, plywood, MDF panels). The best results in terms of structural stability are achieved on high-quality subsurfaces. It is your responsibility to check the suitability of the subsurface; adhesion tests are recommended in certain cases.

General conditions

The bonds should not be subjected to tensile strain. The product achieves its final level of strength only when it has dried. It may be advisable to use mechanical reinforcements to protect the installation area. Once membranes have been stuck, the weight of the insulation material must be supported by laths. Adhesion should be supported by additional laths, if necessary. Ventilate continuously and systematically to prevent build-up of excessive humidity; use a dryer if necessary.

Can also be stored in the event of frost





KLIPFIX

Fastening aid for rolls of joint sealing tape

Makes it easy to close off a roll of joint-sealing tape that has already been started CONTEGA FIDEN EXO.



Advantages

- ✓ The partially used roll is kept closed
- ✓ Prevents the tape from bulging
- ✓ Saves on material and costs

Forms of delivery

Content: 1 piece



TESCON® SPRIMER

Sprayable primer for interior and exterior use

For preparation and improvement of subsurfaces for subsequent adhesion with pro clima adhesive tapes such as TESCON VANA, TESCON PROTECT and adhesive tapes in the EXTONSEAL series. Suitable for wood, wood-fibre boards, masonry, roofs, walls and ground slabs.



Advantages

- ✓ Easy to apply - spray on directly from the can, no contamination of the primer in its container
- ✓ Secure bonds: penetrates deep and strengthens dusty subsurfaces or subsurfaces with insufficient stability
- ✓ Saves time: adhesive tapes can be stuck to absorbent subsurfaces with no drying time
- ✓ Flexible use: use on dry and slightly moist subsurfaces
- ✓ 'At any time of the year: can also be applied during frosty conditions

Technical data

| Substance | |
|-------------------------|--|
| Material | Synthetic rubber |
| Attribute | |
| Value | |
| Colour | translucent |
| Application temperature | -5 °C to 40 °C; 23 °F to 104 °F |
| Temperature resistance | permanent -25 °C to ~90 °C, short-term up to 100 °C (1h); °F: -13 to ~195; 212 |
| Storage | 12 months, protect from frost, cool and dry |

Forms of delivery

Art. no. 1AR01114 – Content: 400 ml; Tape width (Coverage): 60 mm (ca. 20 m), 75 mm (ca. 17 m) und 150 mm (ca. 9 m)
 Art. no. 1AR01050 – Content: 750 ml; Tape width (Coverage): 60 mm (ca. 38 m), 75 mm (ca. 31 m) und 150 mm (ca. 17 m)

Substrates

Before primer is applied, clean the subsurfaces. Frozen and soaked subsurfaces are not suitable for the application of primer. There must be no water-repellent substances (e.g. grease or silicone) on the subsurface. All mineral surfaces (e.g. plaster or concrete) and (used) timber subsurfaces can be pretreated. It is also possible to strengthen porous materials such as wood fibre underlay panels. The primer contains solvents. Subsurfaces are to be checked for compatibility, if necessary. Permeable absorbent subsurfaces (e.g. wood fibre underlay panels) may be slightly moist. In this case, the adhesive tape to be used can be stuck directly onto primer that is still wet. The product achieves its final level of strength only when it has dried. It may be advisable to use covers to protect the area that has been treated. Primer that has not yet fully dried must be protected against the effects of the weather. If butyl rubber tapes (e.g. EXOSEAL range) that hinder diffusion are stuck onto relatively well-sealed, non-absorbent subsurfaces (e.g. concrete), the primer must first be allowed to fully dry before the adhesive tape is put in place. Only ORCON CLASSIC or ORCON MULTIBOND can be used when applying primer for joint adhesives. The primer and ORCON CLASSIC must be fully dried (1-2 days) before the membrane material is stuck in place (dry process).

General conditions

Shake the can well before application. The fan-shaped spray jet can be adjusted in the horizontal and vertical directions by turning the spray head nozzle. After every spray application, spray the can upside down until only blowing agent comes out so as to avoid blocking the valve riser tube and the spray head with primer residues. Wipe off any primer at the outlet of the nozzle. Spray the surface to be stuck after cleaning it – spray distance 20 - 25 cm (8" - 10"). Allow to ventilate for between 5 and 15 min. (depending on material and application). Repeat this procedure again for absorbent subsurfaces.

TESCON® PRIMER RP

Solvent-free primer for interior and exterior use

For preparation and improvement of subsurfaces for subsequent adhesion with pro clima adhesive tapes such as TESCON VANA, TESCON PROTECT and adhesive tapes in the EXTOSEAL series. Suitable for wood, wood-fibre boards, masonry, roofs, walls and ground slabs.



Advantages

- ✓ Secure bonds: penetrates deep and strengthens dusty subsurfaces or subsurfaces with insufficient stability
- ✓ Saves time: no drying time is necessary on absorbent subsurfaces
- ✓ More flexible work: use on dry and slightly moist subsurfaces
- ✓ Can be applied and spread with just one hand using the application bottle
- ✓ Can be used at any time of the year: can also be applied during frosty conditions
- ✓ Excellent values in the hazardous substance test, has been tested according to the ISO 16000 evaluation scheme, solvent-free

Technical data

| | Substance |
|-------------------------|---|
| Material | acrylic copolymer, solvent-free |
| Attribute | Value |
| Colour | white |
| Application temperature | -10 °C to 45 °C; 14 °F to 113 °F |
| Temperature resistance | permanent -40 °C to 90 °C; -40 °F to 194 °F |
| Storage | protect from frost, cool and dry |

Forms of delivery

Art. no. 11449 – Content: 1000 ml; Tape width (Coverage): 60 mm (ca. 75 m), 75 mm (ca. 60 m) und 150 mm (ca. 30 m)
 Art. no. 11427 – Content: 750 ml; Tape width (Coverage): 60 mm (ca. 60 m), 75 mm (ca. 45 m) und 150 mm (ca. 22 m)
 Art. no. 11430 – Content: 2500 ml; Tape width (Coverage): 60 mm (ca. 185 m), 75 mm (ca. 150 m) und 150 mm (ca. 75 m)

Substrates

Before primer is applied, clean the subsurfaces. Frozen and soaked subsurfaces are not suitable for the application of primer. There must be no water-repellent substances (e.g. grease or silicone) on the subsurface. All mineral surfaces (e.g. plaster or concrete) and (used) timber subsurfaces can be pretreated. It is also possible to strengthen porous materials such as wood fibre underlay panels. Permeable absorbent subsurfaces (e.g. wood fibre underlay panels) may be slightly moist. In this case, the adhesive tape to be used can be stuck directly onto primer that is still wet. The product achieves its final level of strength only when it has dried. It may be advisable to use covers to protect the area that has been treated. Primer that has not yet fully dried must be protected against the effects of the weather. If butyl rubber tapes (e.g. EXOSEAL range) that hinder diffusion are stuck onto relatively well-sealed, non-absorbent subsurfaces (e.g. concrete), the primer must first be allowed to fully dry before the adhesive tape is put in place. Only ORCON CLASSIC or ORCON MULTIBOND can be used when applying primer for joint adhesives. The primer and ORCON CLASSIC must be fully dried (1-2 days) before the membrane material is stuck in place (dry process).

General conditions

Shake or stir the can well before use. One litre of primer can be used to treat an area of about 4.5 m² (48 ft²). For particularly quick and easy application insert the 1-litre dispenser bottle in to the TENAPP application tool. Advantages: Application and distribution in just one step, using just one hand and no contamination of the primer in the container.



A simple approach to achieve the perfect window joint

No matter how small your window joints may be, it is still extremely important to plan installation carefully in advance and then carry it out carefully too. This process can be considered in terms of the following steps:

Planning phase

1. Design, wall type, determine the statics and window position, assessment of installation situation on site

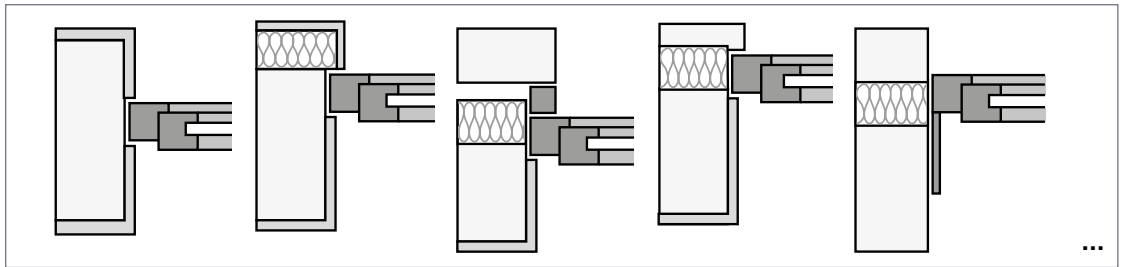

2. Specify the window material

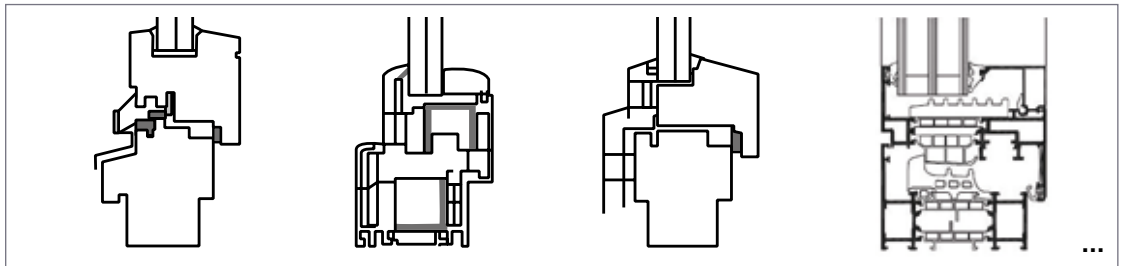

3. Specify the window type

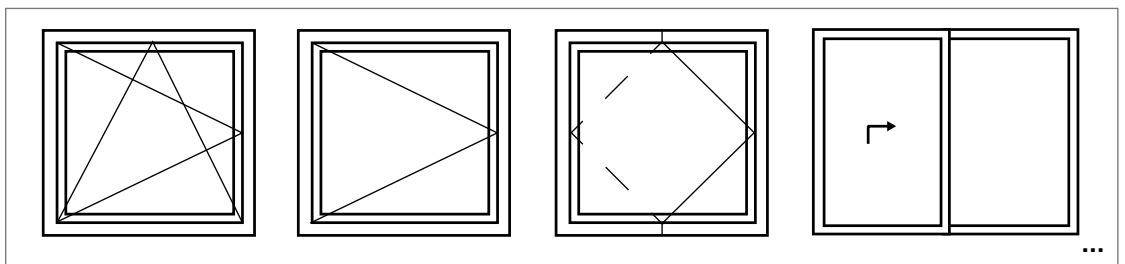



Installation phase

Example: Tilt and turn window made of plastic, installation flush on the outside, masonry with thermal insulation composite system, new-build project



Working steps

1. Check the subsurface page 48
2. Prepare airtightness on the inside page 48
3. Insert the window page 55
4. Insulate the joint page 58
5. Create exterior weather protection page 59
6. Install sub-sill flashing page 61
7. Complete airtightness on the inside page 63
8. Quality assurance, acceptance and documentation page 64



Step 1: Check the subsurface

Example: Tilt and turn window made of plastic, installation flush on the outside, masonry with thermal insulation composite system, new-build project

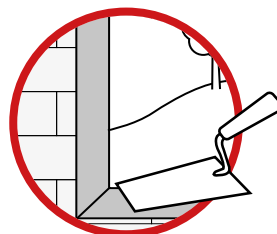
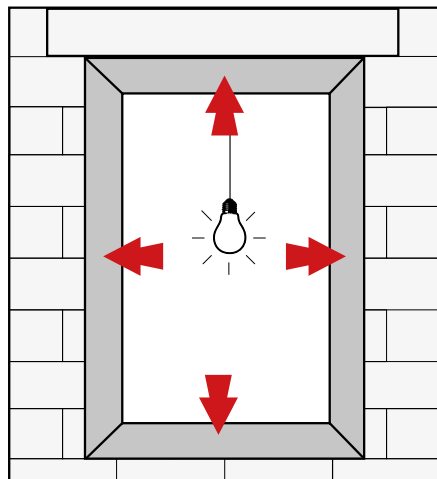

Smooth finish must be present

Check the characteristics of the subsurface

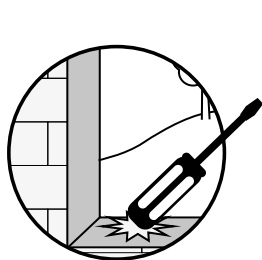

Tap surface carefully

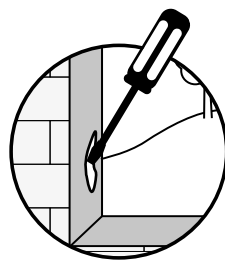

Try to rub surface



Free of frost

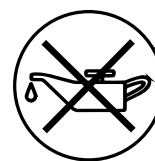

Free of grease and oil

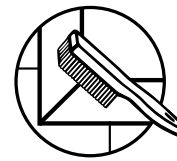

Clean / brush off

Step 2: Prepare airtightness on the inside

Practical tip

Stick CONTEGA joint adhesive tapes to the frame before installing the window: simple application of the adhesive tape – reliable sealing – valuable time saved!

Note

Joints between corners, clip-on profiles, wideners and covering strips are to be carried out in a manner that is airtight and/or resistant to driving rain. Open ends can be closed off with EXTONSEAL ENCORS.

1. If necessary, clip on the frame profile covers and then clean the frame profile

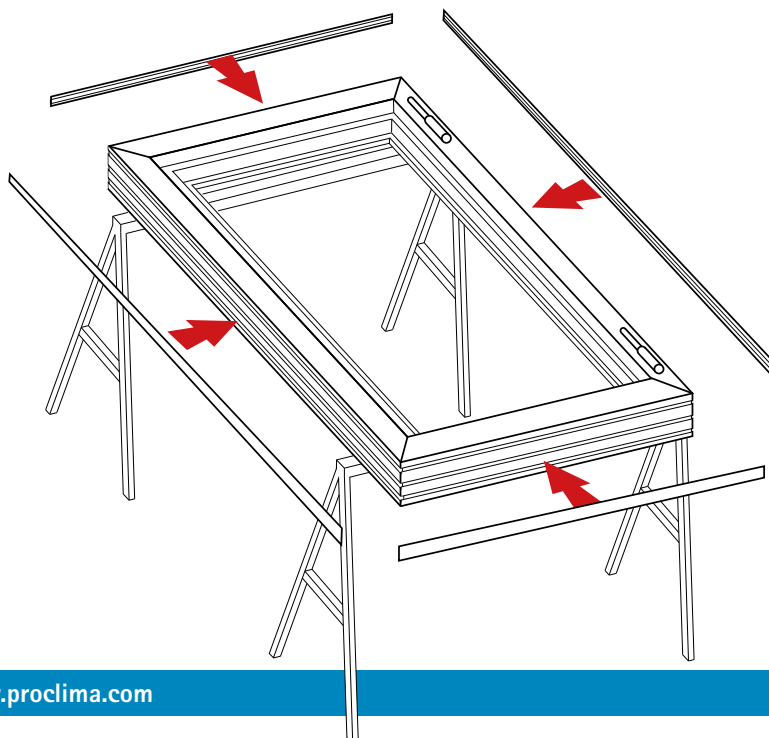



2. Stick CONTEGA SOLIDO SL on the inside of the frame

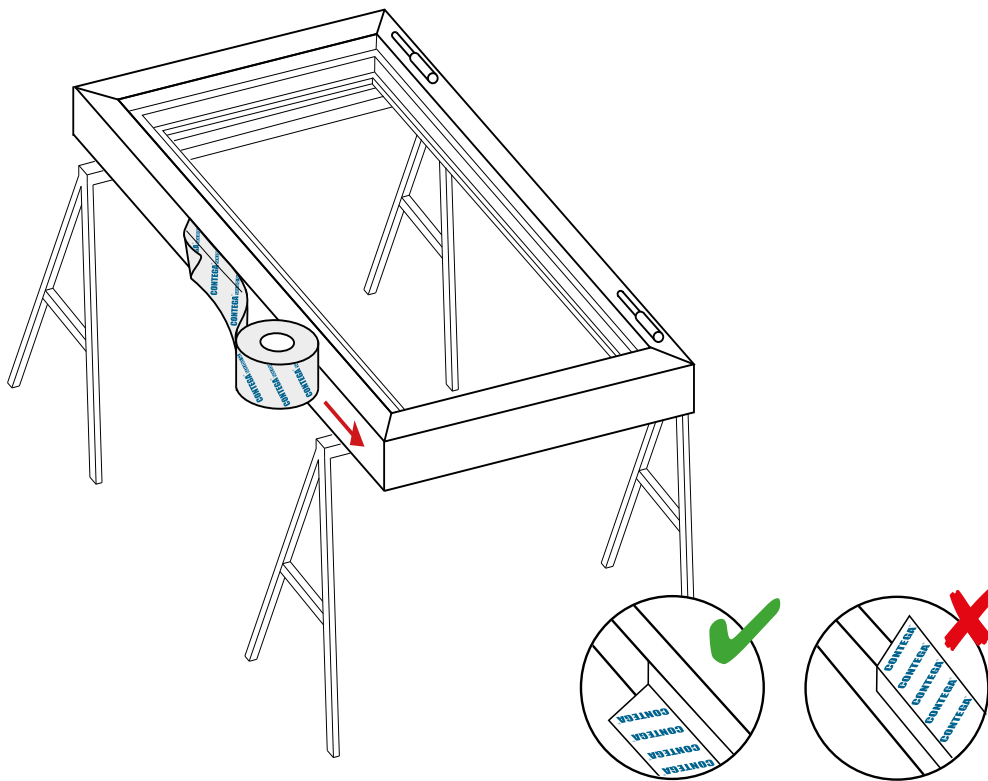

3. Create the corner slack loops

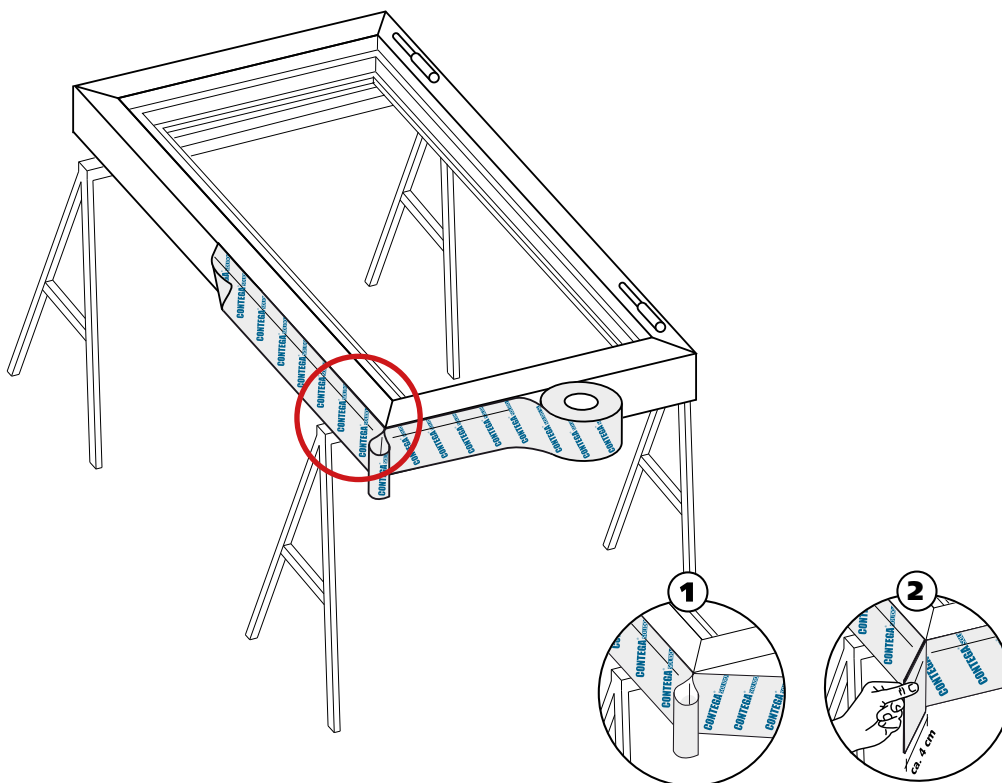

CONTEGA[®] SOLIDO SL

Permeable, full-surface adhesive sealing tape for interior use that can be plastered over



© ift Rosenheim
 Prüfbericht Nr. 16-000527-PRO2
 (PB 1-E03-020310-de-01)
 - CONTEGA SOLIDO SL
 - CONTEGA SOLIDO EXO
 nach MO-01/1:2007-01, Abs. 5
 24.06.2016

Note

Why create slack loops at the corners? The tape can then be folded after the window has been inserted into the corners of the soffit and can be stuck in a secure, airtight manner. The corner slack loop should be at least 4 cm, i.e. approx. double the joint width.



4. Stick CONTEGA SOLIDO SL around the perimeter

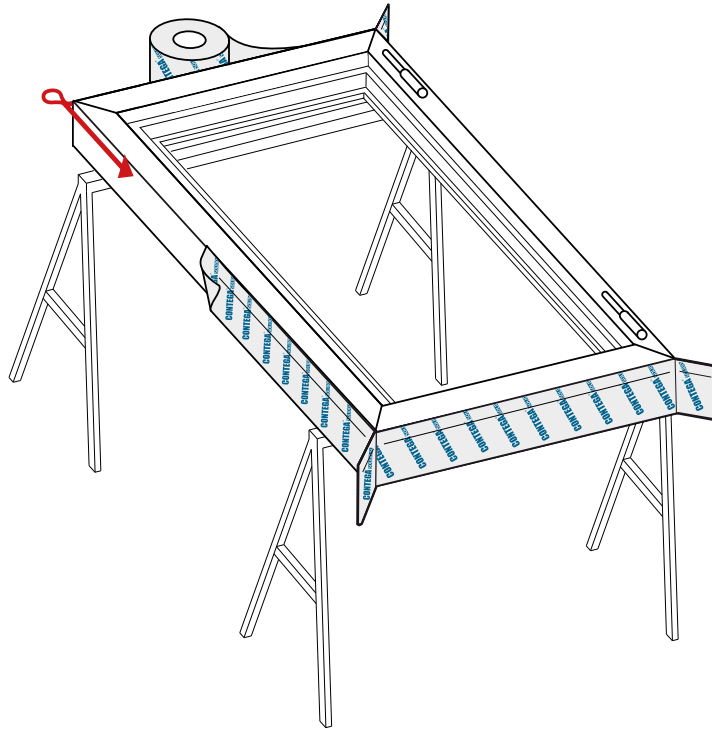

5. Stick the ends

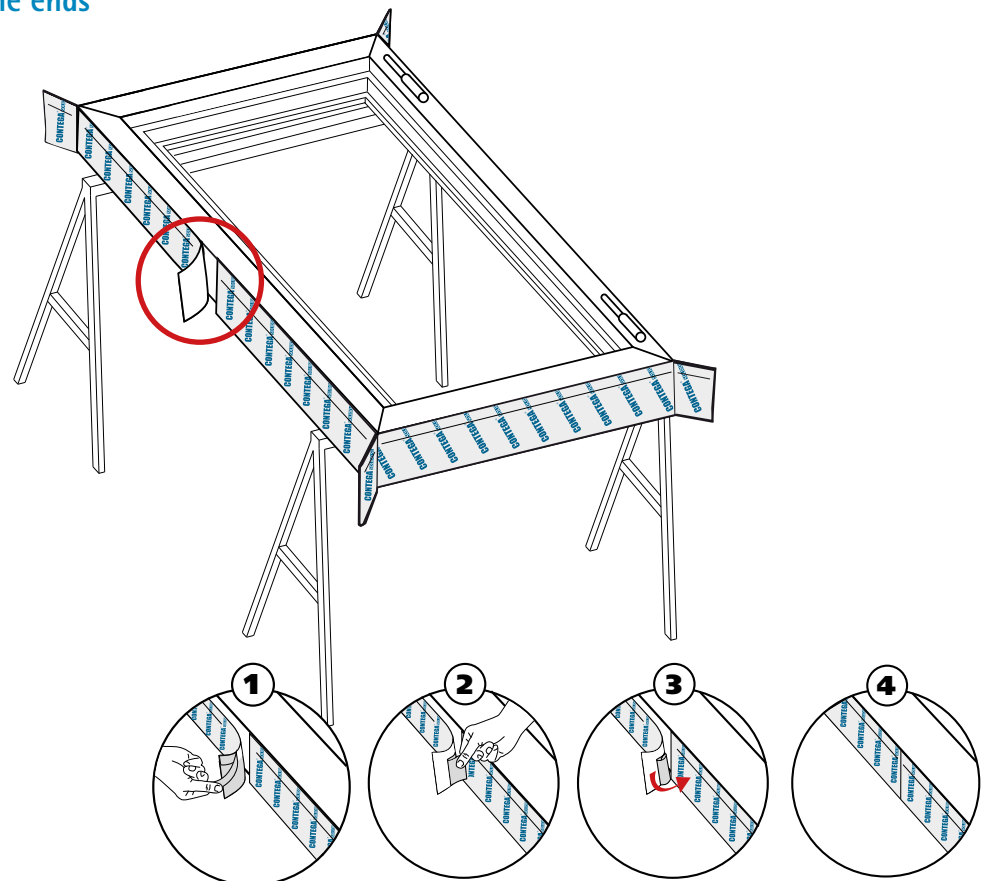



6. Press firmly to secure the adhesive tape

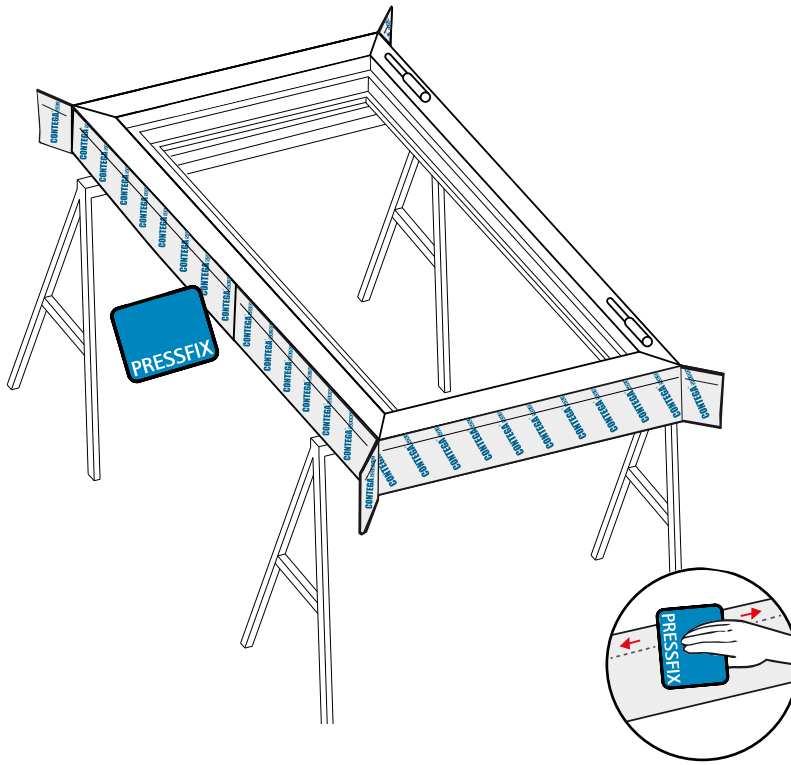

PRESSFIX
application tool



7. Inside of the frame

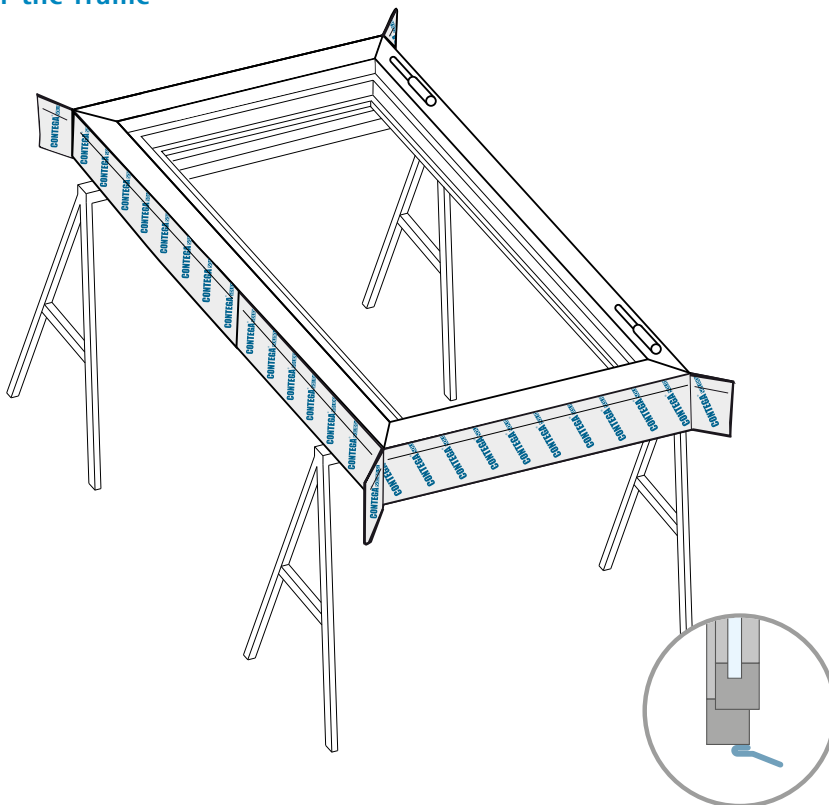

 **Finished!**



Removable adhesive tape



Practical tip

Holding in place with removable adhesive tape makes it easier to slide the window into the window opening.

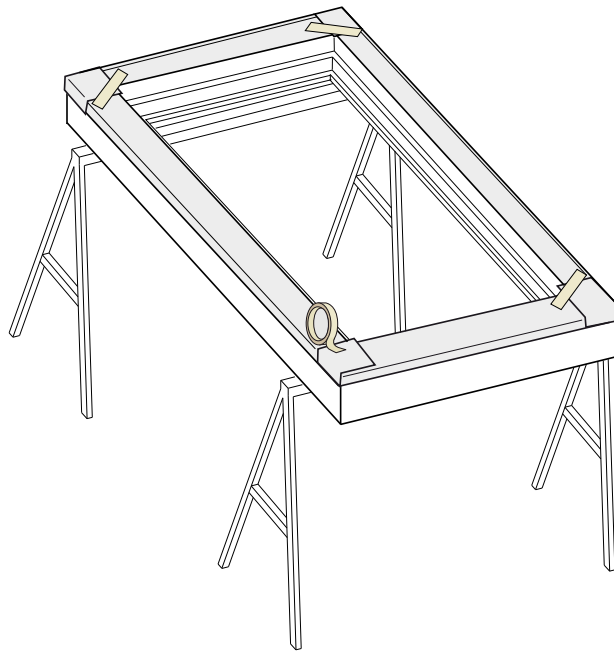
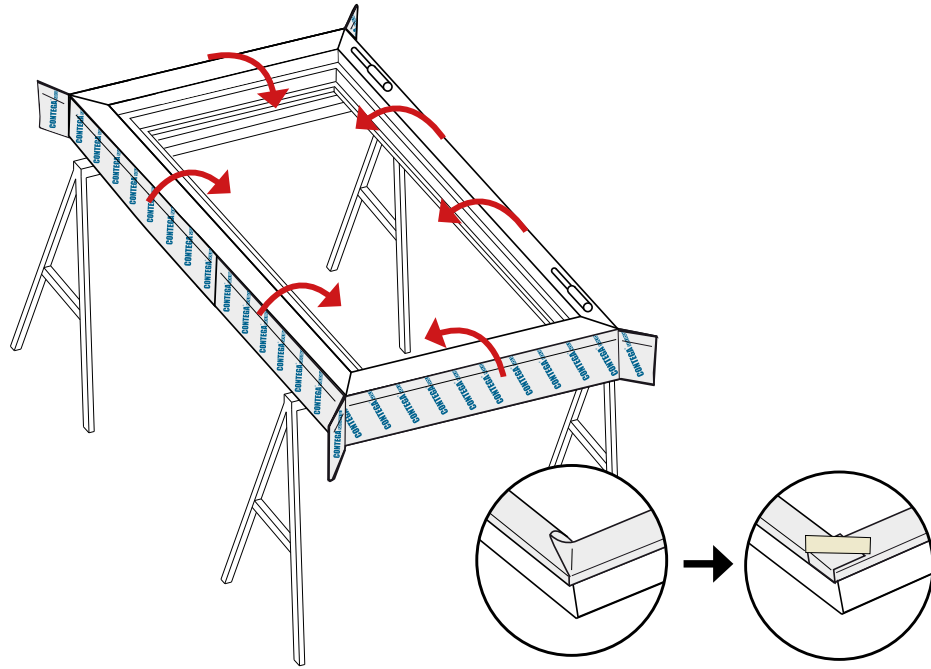

Product variant

with CONTEGA SOLIDO SL-D

Product variant with additional adhesive zone on the fleece side: No folding over necessary (cf. page 44)

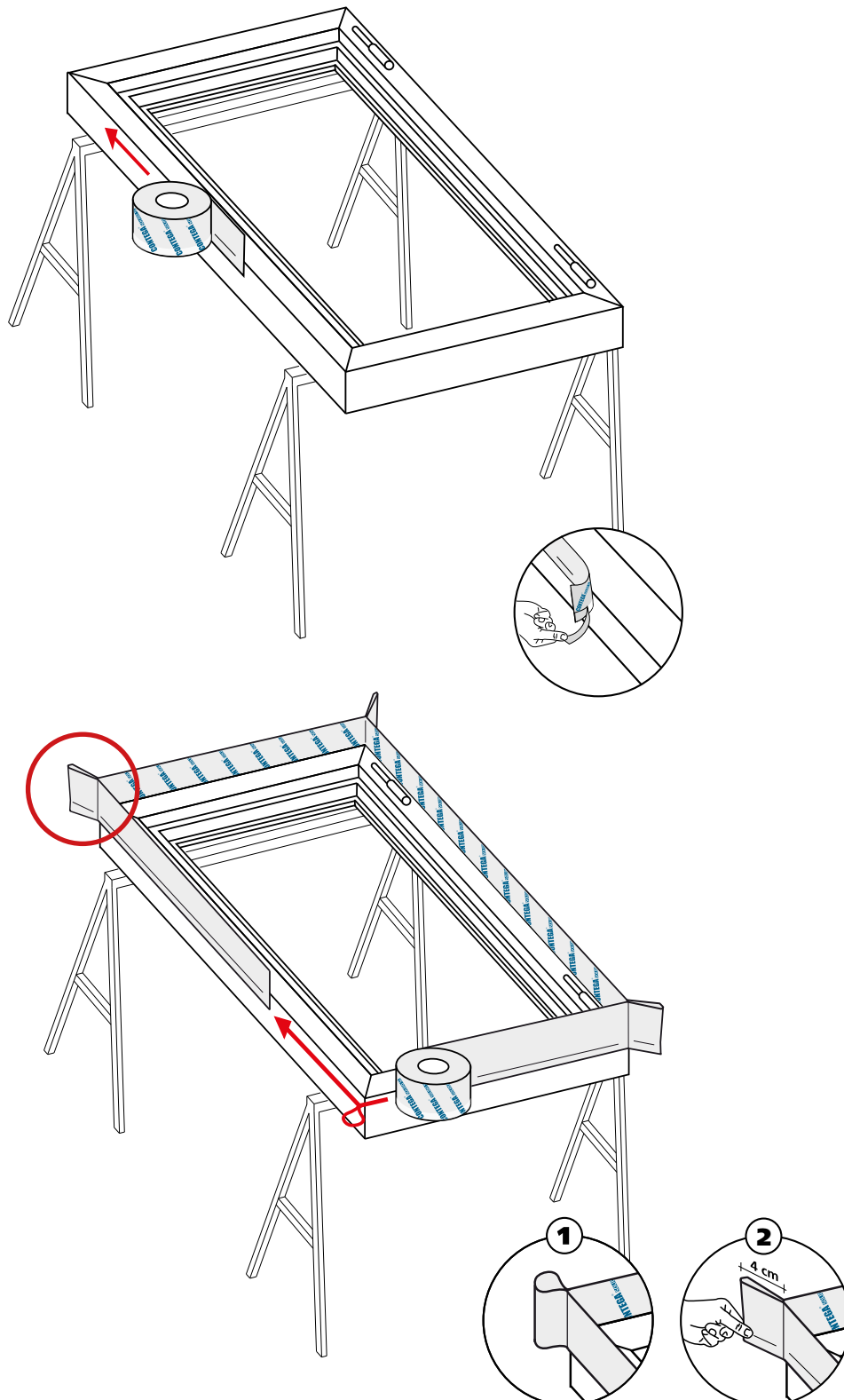

CONTEGA[®] SOLIDO SL-D

Permeable, full-surface adhesive sealing tape for interior use that can be plastered over



ift Rosenheim
Prüfbericht Nr. 15-003305-PR01
(PB-E03-020310-de-02)
+ CONTEGA SOLIDO SL-D
+ CONTEGA SOLIDO EXD-D
nach MO-01/1:2007-01, Abs. 5
15.03.2016

Note

Why create slack loops at the corners? The tape can then be folded after the window has been inserted into the corners of the soffit and can be stuck in a secure, airtight manner. The corner slack loop should be at least 4 cm, i.e. approx. double the joint width.



Product variant

with CONTEGA SOLIDO IQ-D

Just one tape for interior and exterior use: Humidity-variable sd value for dry joints. Easier stock management.

CONTEGA SOLIDO IQ-D

Intelligent full-surface adhesive window sealing tape for interior and exterior use with additional adhesive zone



NEW

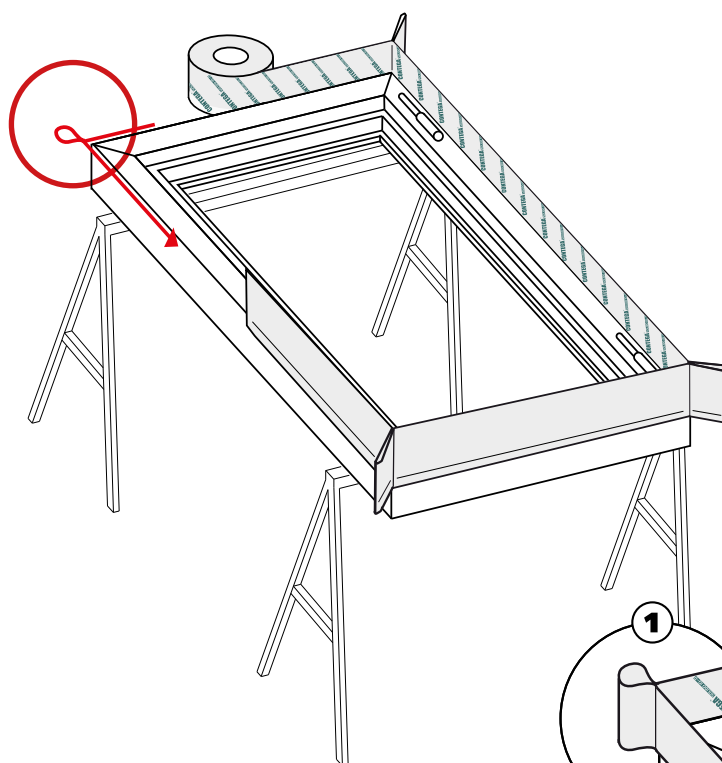
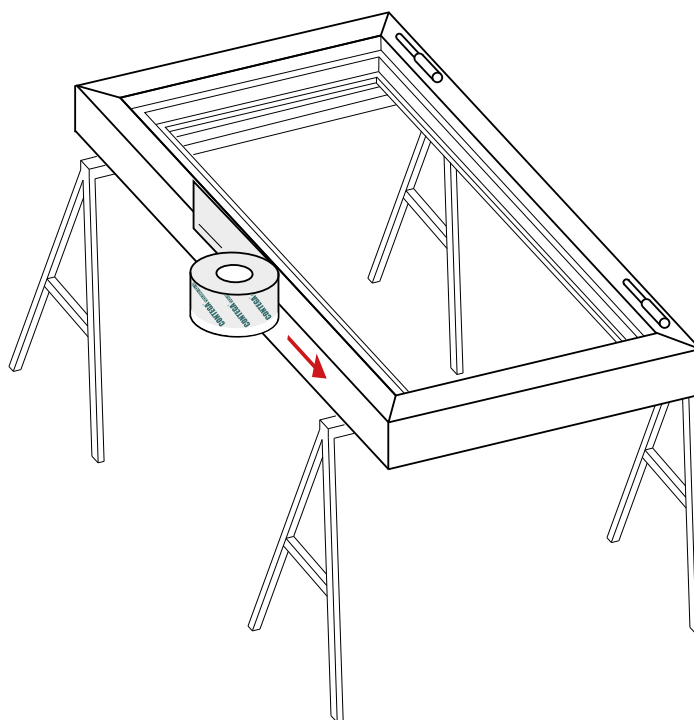

Note

Why create slack loops at the corners? The tape can then be folded after the window has been inserted into the corners of the soffit and can be stuck in a secure, airtight manner. The corner slack should be approx. 4 cm, and at least double the joint width.

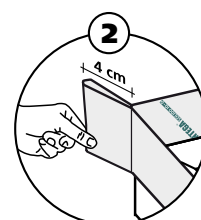
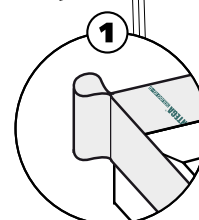



Step 3: Insert the window

1. Provide load-transferring as per planning

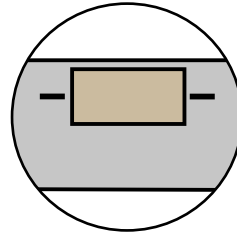
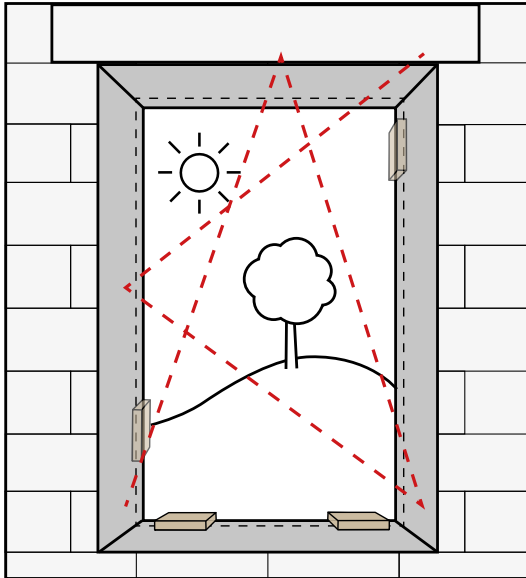

Practical tip

Setting blocks need not be used if appropriately sized, suitable fasteners are used and if the window is placed on a load-bearing insulation material.

Note

The fastening system and load-transferring are dependent on the permitted edge distances, the relevant masonry type and the selected fasteners. The type, position and number of fasteners should be specified as part of planning.

2. Lift the frame into place

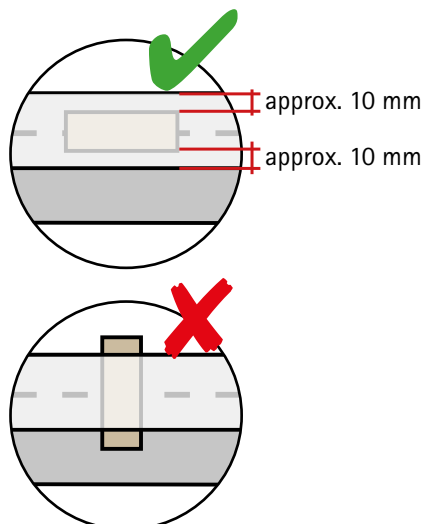
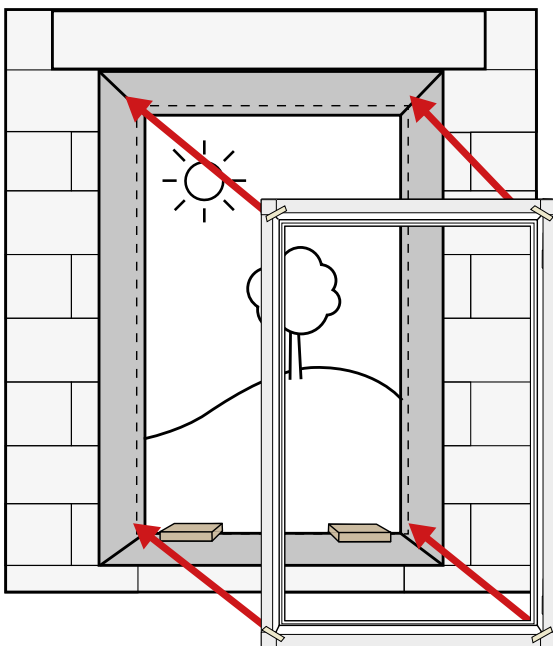

Note

If setting blocks have to be used, they must be pressure-resistant and must keep their shape (hardwood or plastic). They must not protrude beyond the frame.



3. Align the window and fasten in place

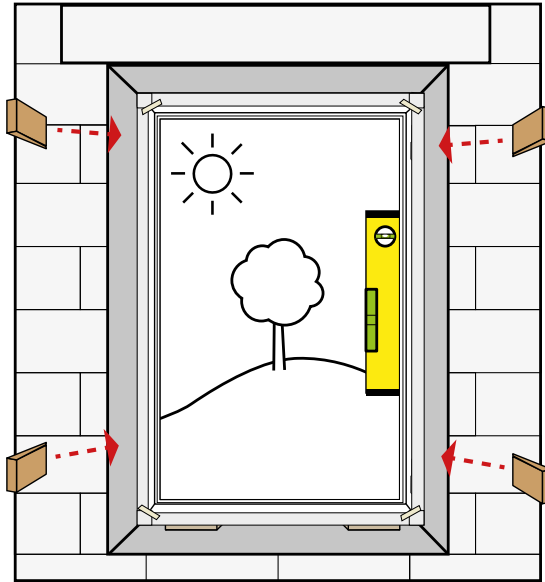

Fastening aids: Wedges, air cushions etc.

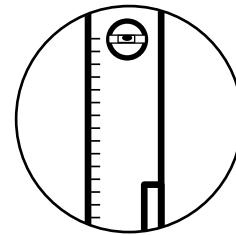

Vertical

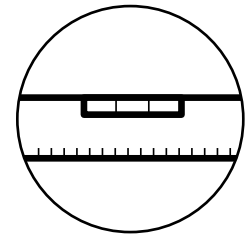

Horizontal

Note

Give consideration to installation heights and facade alignments.

4. Ensure load-transferring is provided

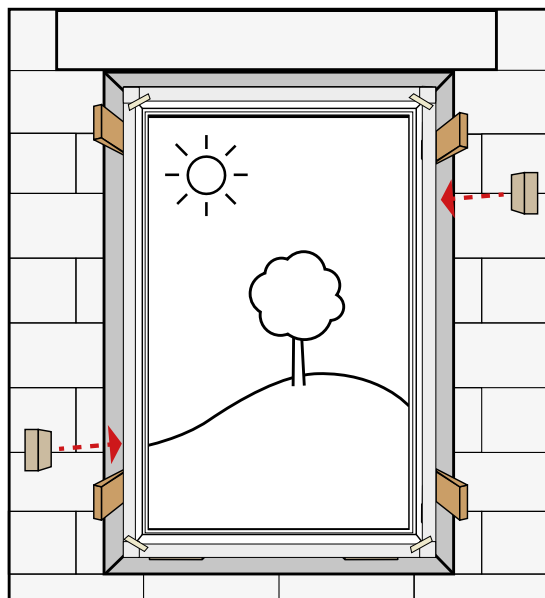

If load-transferring is not carried out by the fastening system, setting blocks at the sides and bottom are generally used. Give consideration to permanent securing of positioning and to a snug fit.



5. Fastening the window

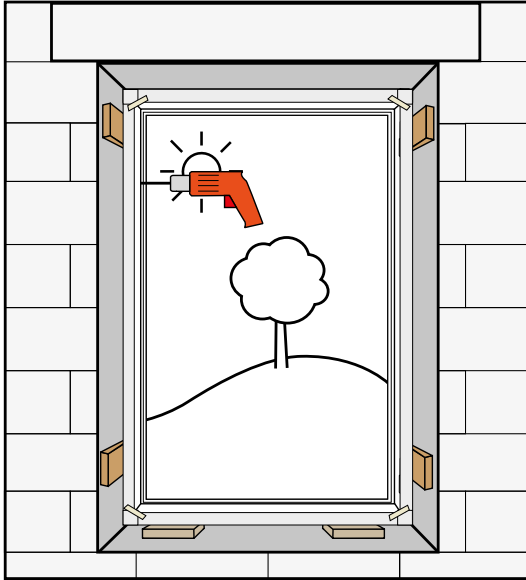

Fastening system: Take into account statics requirements; must be integrated into the window seal. Observe the edge distances of the fasteners, adapt the supporting system if necessary.

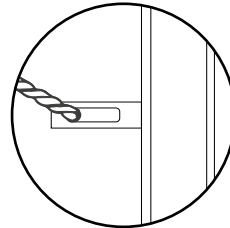

Insert dowels into the soffits

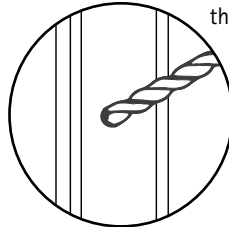

Drill

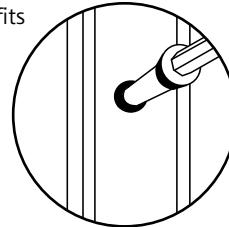

Fasten the window using a suitable system

6. Remove the fastening aids

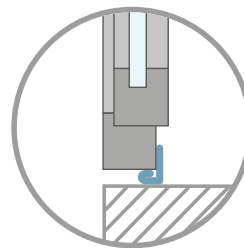
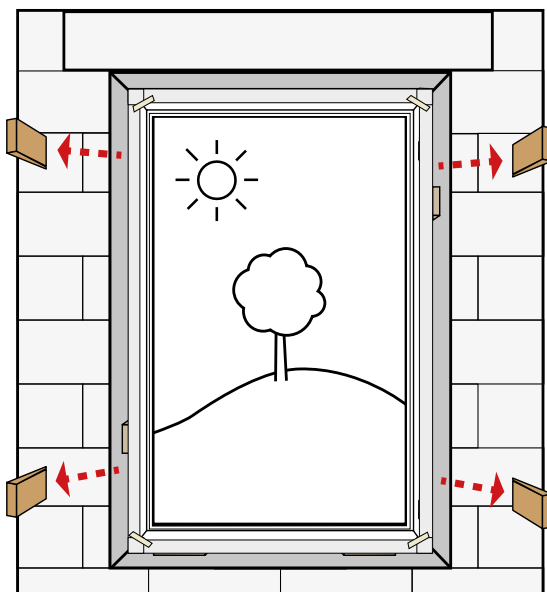



Step 4: Insulate the joint

Practical tip

Start inside or outside? Examine the existing situation

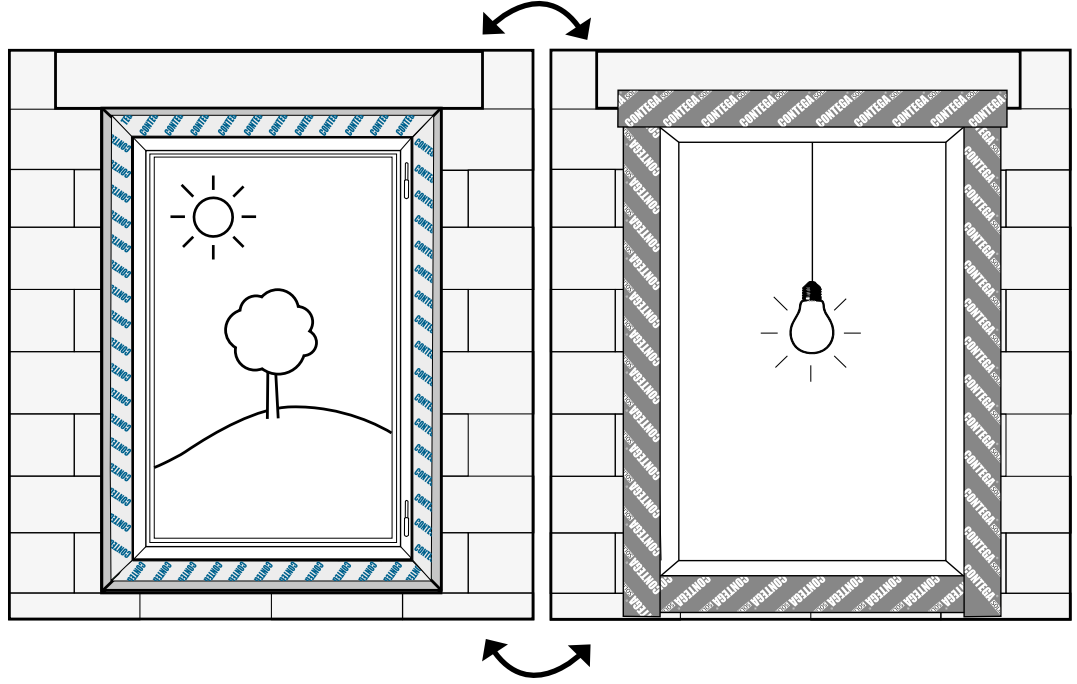

Start sealing inside or outside? Decide based on the local site conditions, such as weather or stage of progress of construction – this does not depend on the pro clima joint adhesive tapes.

1. Fill the joint with insulation material

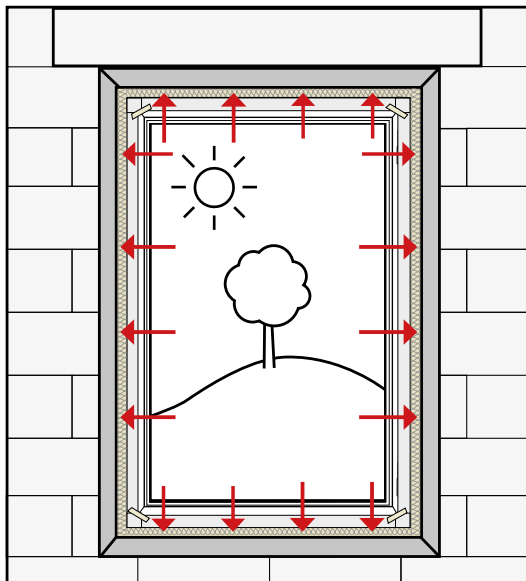

Practical tip

Folding over the joint adhesive tape in advance will make it easier to insert the insulation. Install the insulation material around the profile. This makes it easier to carry out adhesion for the interior and exterior sealing layers.

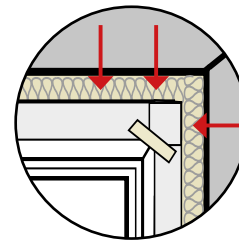

Fill the joint with insulation material around the perimeter, leaving no cavities

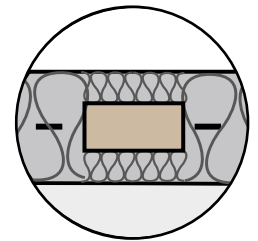

Insulate over setting blocks



Step 5: Create exterior weather protection

1. Stick the tape in place around the perimeter

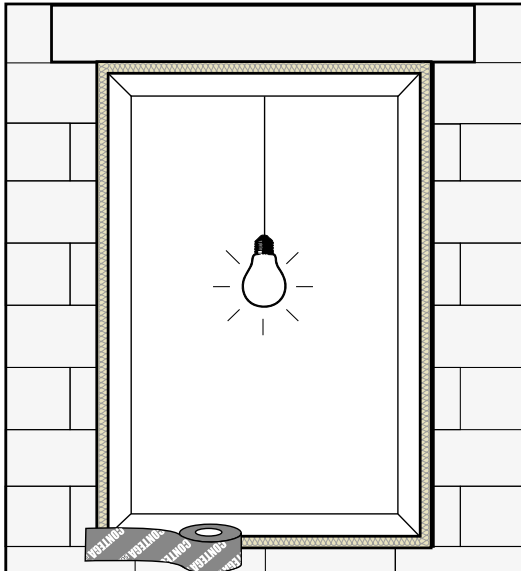

Differences in depth between the window profile and the building structure should be stuck over in a manner free of tension and free of gaps.

2. Stick the tape in place around the perimeter

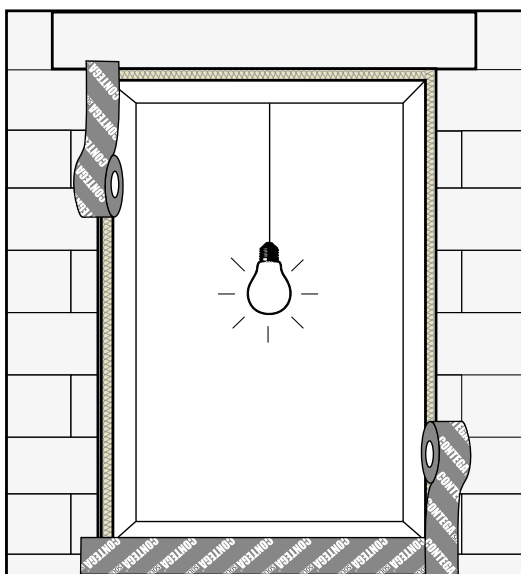

Note

Adhesive joints that are resistant to wind and driving rain can only be achieved if the sealing tape is installed free of folds and break.



3. Stick the tape in place around the perimeter

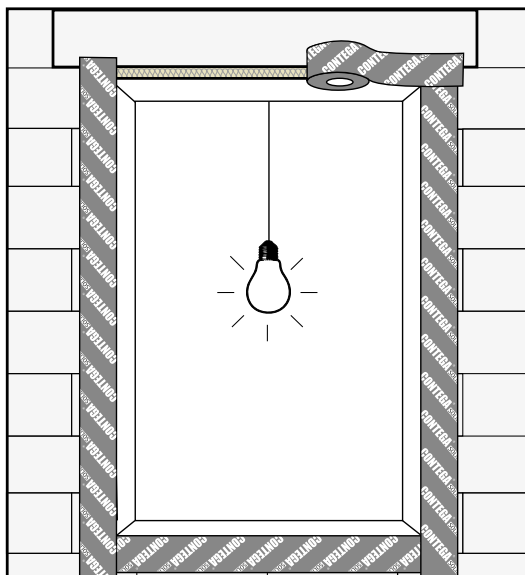

Note

Adhesive joints that are resistant to wind and driving rain can only be achieved if the sealing tape is installed free of folds and break.

4. Stick the tape in place around the perimeter

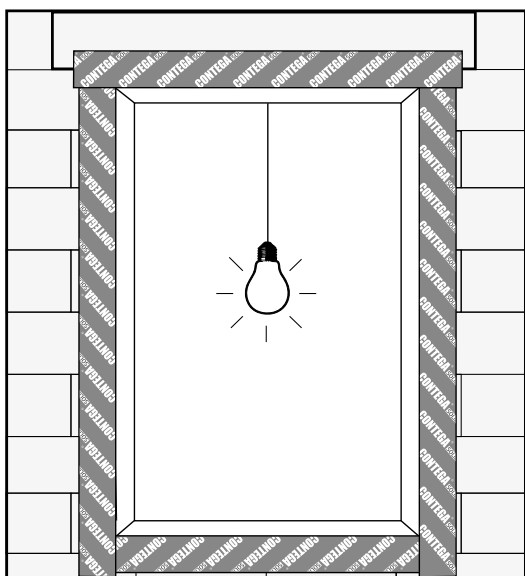

Finished!

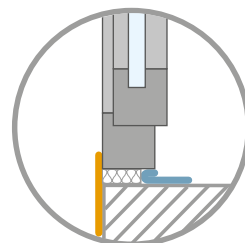



Step 6: Install sub-sill flashing

1. Install the thermal insulation composite system in a system-compatible manner

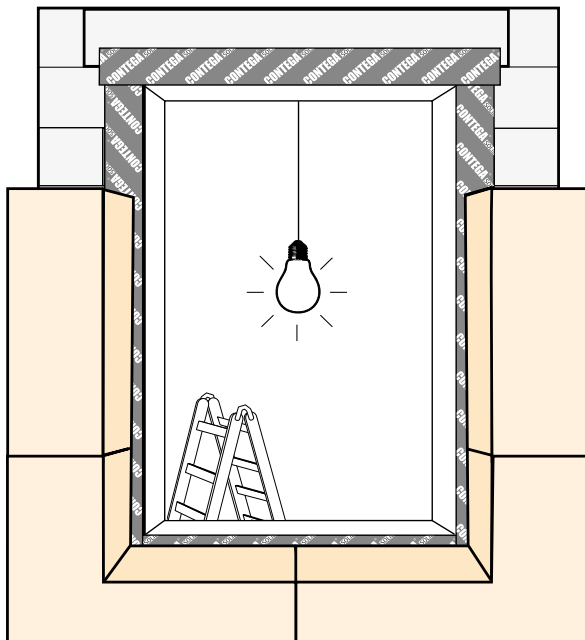

The thermal insulation composite system should be installed in accordance with the technical approval of the selected system. As a result, the following steps for the sub-sill flashing should be adapted for the relevant thermal insulation composite system if necessary.

CONTEGA[®] FIDEN EXO

Pre-compressed joint sealing tape for exterior use that is open to diffusion and resistant to driving rain



If soffit insulation and/or the edge profile of the window sill is installed, these can be bonded to the subsurface in a sealed manner using CONTEGA FIDEN EXO.

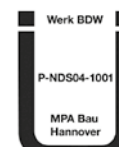

Nur schwer entflammbar (DIN 4102-B1) zwischen massiven, mineralischen Baustoffen.

2. Cut EXTONSEAL ENCORS to size allowing for excess

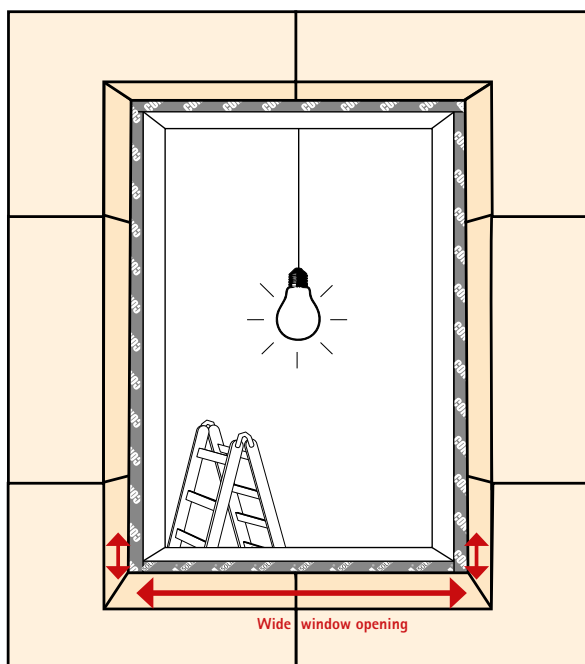

Length of EXTONSEAL ENCORS = Width of window opening + 2 x double the height of the window sill profile

Note

Add a soffit plate to EXTONSEAL ENCORS before plastering, or stick on TESCON VANA in the plastering area, or add suitable reinforcement to the plaster. EXTONSEAL ENCORS is shown as sub-sill flashing in this example; primarily observe the installation instructions of the manufacturer of the thermal insulation composite system.

EXTONSEAL[®] ENCORS

Waterproof adhesive tape with high adhesion



© ift Rosenheim
Prüfbericht Nr. 16-000527-PR02
[PB 2-E03-020310-de-01]
Unterfensterbank EXTONSEAL ENCORS
mit CONTEGA SOLIDO EXO
nach MO-01/1:2007-01, Abs. 5
24.06.2016



3. Remove the wide release film and stick EXTONSEAL ENCORS into the bottom of the soffit

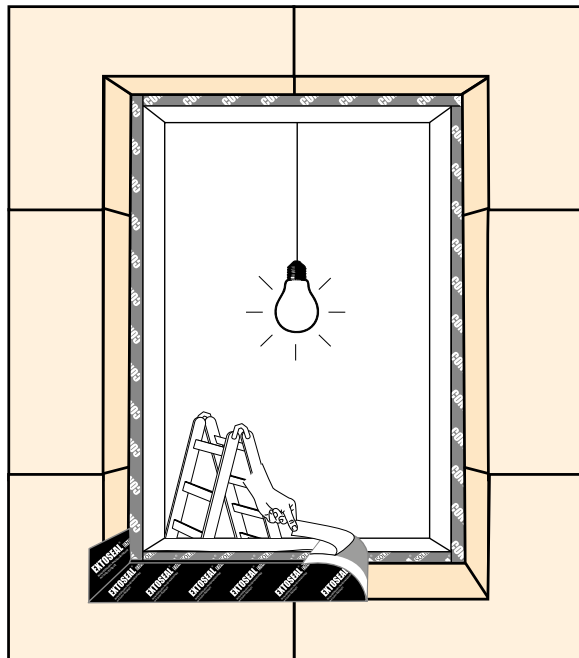

Note

Stick EXTONSEAL ENCORS into the soffit in such a way that the side with the narrow release film protrudes on the outside. This is subsequently stuck onto the plaster layer or plastering reinforcement beads. Guide the tape exactly into the corners and rub firmly into place.

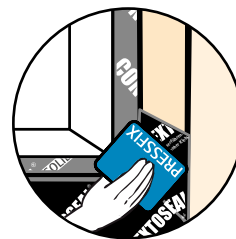

Stick to the soffit sides

4. Cut off vertical excess

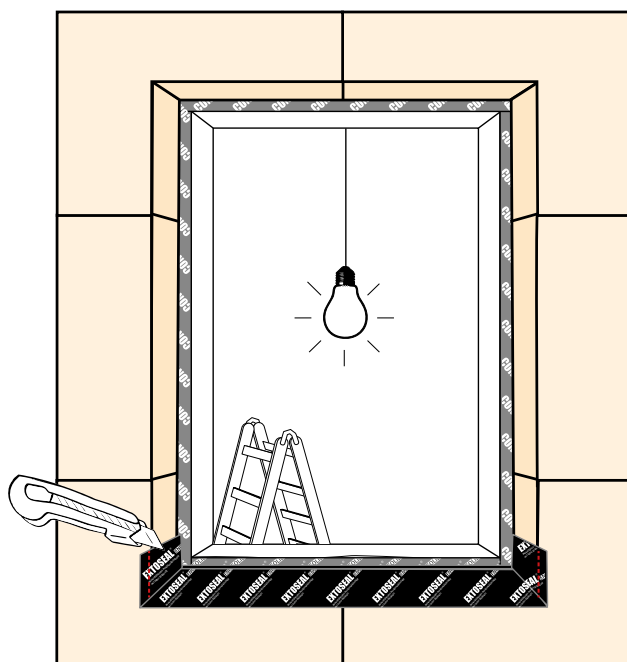

The soffit is to be installed in accordance with the selected thermal insulation composite system. Observe the relevant manufacturer's specifications.



5. Stick EXTONSEAL ENCORS

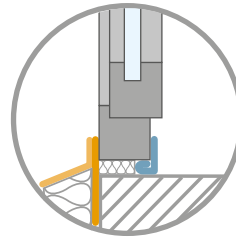
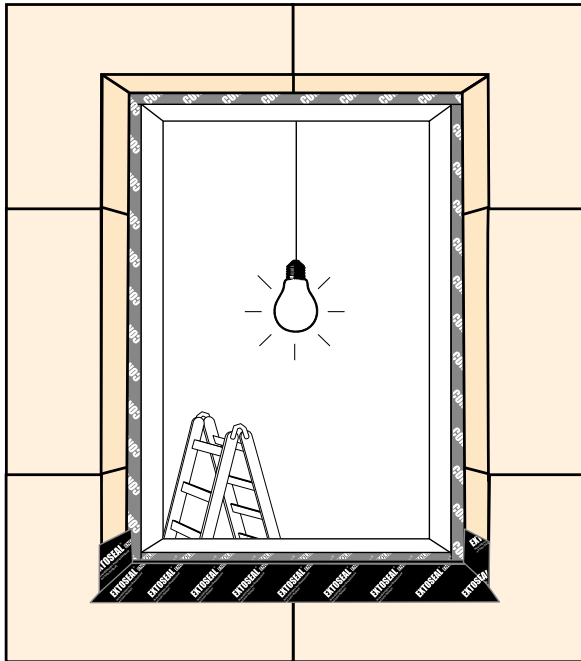

Note

Guide the tape exactly into the corners and rub firmly into place everywhere.

Note

Add a soffit plate to EXTONSEAL ENCORS before plastering, or stick on TESCON VANA in the plastering area, or add suitable reinforcement to the plaster. EXTONSEAL ENCORS is shown as sub-sill flashing in this example; primarily observe the installation instructions of the manufacturer of the thermal insulation composite system.



Step 7: Complete airtightness on the inside

1. Stick the tape around the soffit

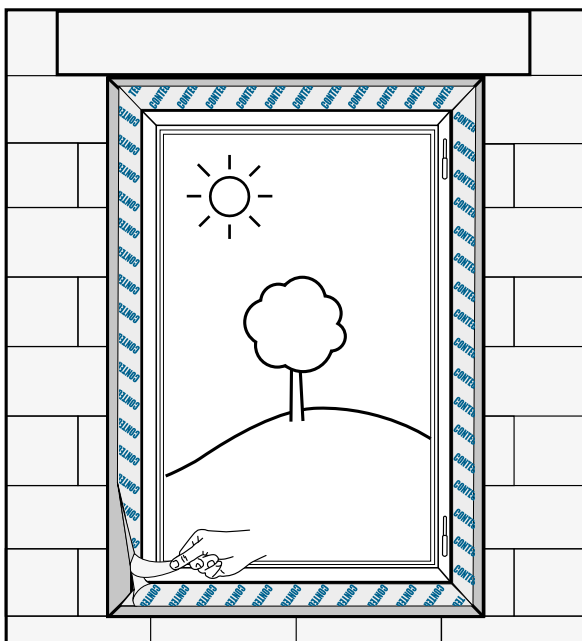

Remove the release film



Rub using the PRESSFIX tool to secure

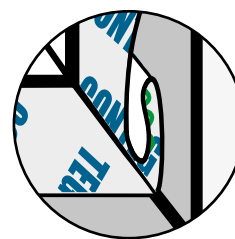

Fasten the corner with ORCON F

Note

Stick the tape with slack to allow for movement.





2. Interior airtightness: finished

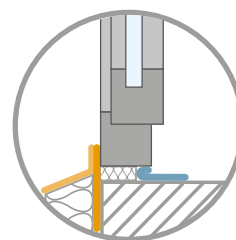
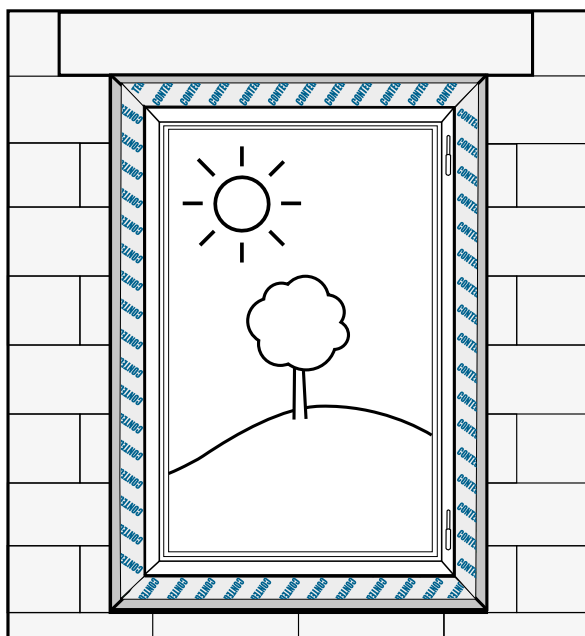

Finished!

Step 8: Quality assurance, acceptance and documentation

1. Visual inspection on the inside and outside

Note

Careful visual inspection of work carried out is essential. This check, along with documentation of quality, should be carried out before other trades begin their work. At this stage, improvements can still be carried out quickly and easily.

Practical tip

Take photos of the installed window. This does not take much time, but offers a major benefit: you can document the quality of your work before subsequent trades start their work.

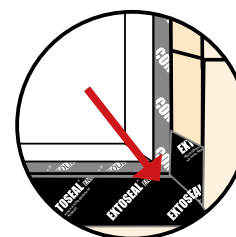
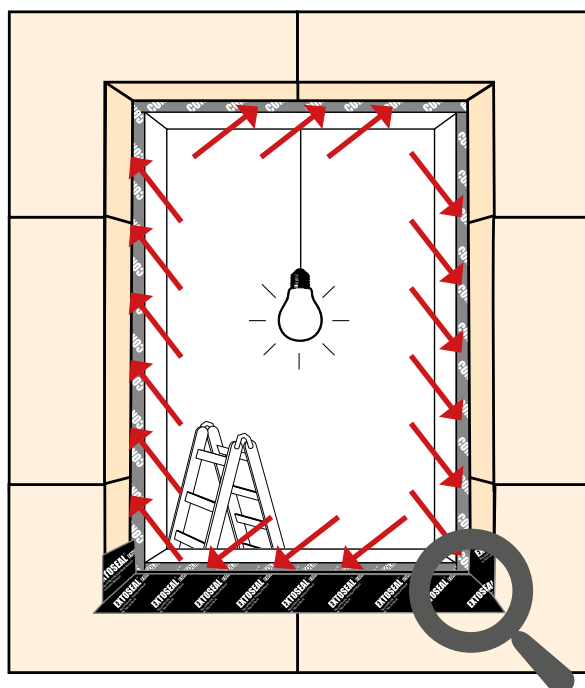



2. Differential pressure test with BlowerDoor



BlowerDoor

The BlowerDoor procedure is a testing method that creates a differential pressure in the building. This differential pressure allows defects in the joints to be identified and rectified. This procedure can also be used to measure the air change rate (n_{50}) in the building.

Practical tip

Consult with other trades (e.g. roofers, carpenters, plasterers...) beforehand, as a blower door test may already be planned and a number of trades can then take advantage of this test at the same time. And the client will save money too!

Technical support

- Immediate answers relating to building physics
- pro clima's engineers can help you with their specialist knowledge
- Advice on installation and use of systems and products

IE Ecological Building Systems

Phone: 00353 46 9432104

Fax: 00353 46 9432435

eMail: info@ecologicalbuildingsystems.com

UK Ecological Building Systems UK

Phone: 0044 1228 711511

Fax: 0044 1228 712280

eMail: info@ecologicalbuildingsystems.com

NZ Pro Clima NZ Limited

Phone: 0800 PRO CLIMA (776 254)

Fax: 04 589 84 61

eMail: welcome@proclima.co.nz

USA 475 High Performance Building Supply

Phone: NY 11231

Fax: 800-995-6329

eMail: info@foursevenfive.com



Notes

pro clima WINDOWS

Sealing systems for professionals



The applications and conditions described here are based on current state-of-the-art research and practical experience at the time of printing. We reserve the right to change the recommended structures and processing methods and to further develop and thus alter the quality of individual products. We would be glad to inform you about the current state of engineering knowledge at the time that your installation is carried out.

2020-02 1AR01399

Ecological Building Systems

For stockist information and full technical support for your project, please contact Ecological Building Systems or visit www.EcologicalBuildingSystems.com



Ireland: 046 9432104 Fax: 046 9432435 UK: 01228 711 511 Fax: 01228 712 280

info@EcologicalBuildingSystems.com