

Planning Manual

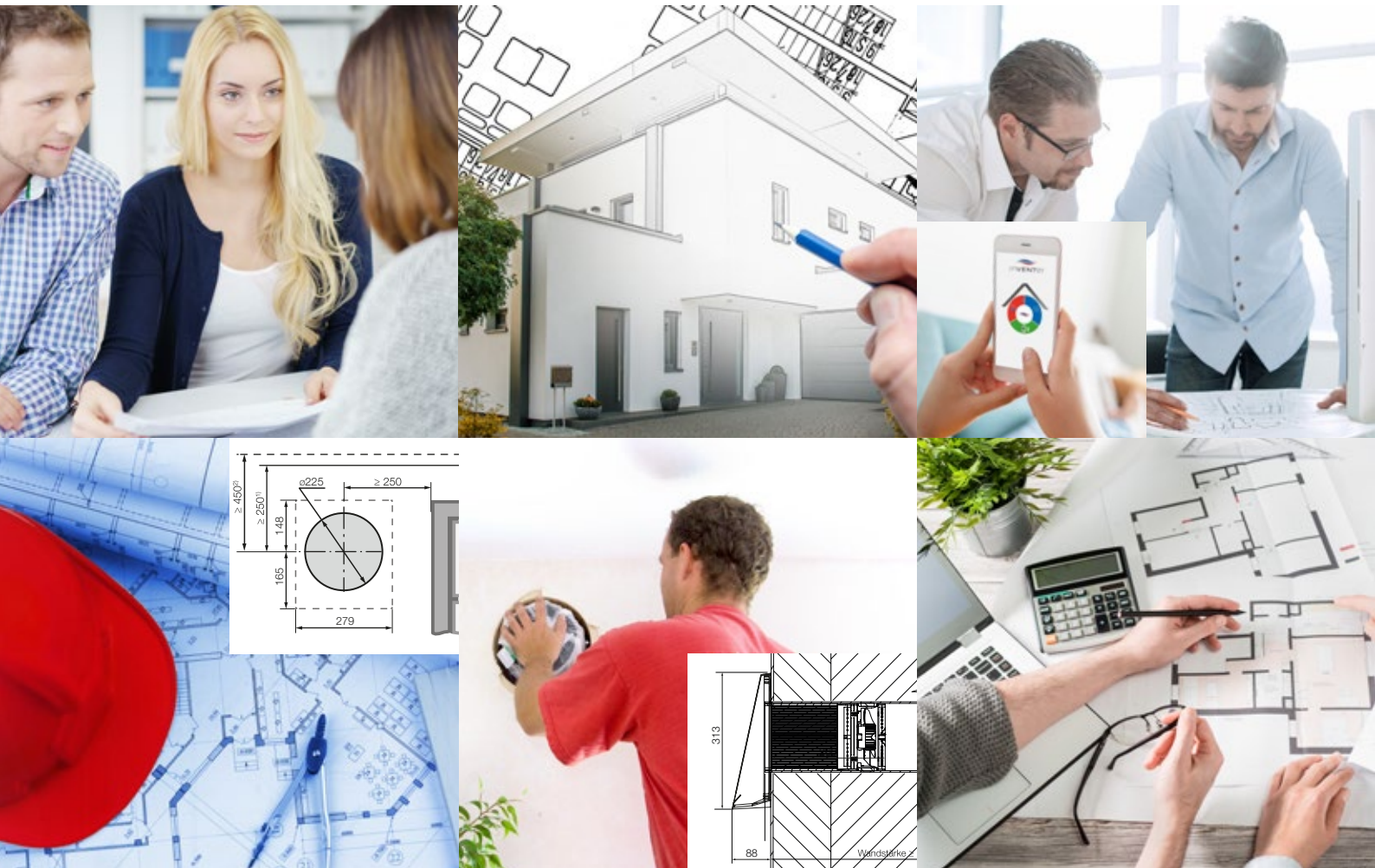

www.inventer.eu

Ecological Building Systems

For sales and full technical support, please contact Ecological Building Systems or visit www.EcologicalBuildingSystems.com





inVENTer

simply fresh air

Planning Manual

Decentralised Residential Ventilation

Disclaimer

The content of this documentation has been carefully checked for compliance with the hardware and software described. Nevertheless, deviations, e.g. changes or in the meantime omission of components, cannot be excluded due to constant further development of our products, so that no guarantee can be assumed for complete conformity and freedom from errors.

Statements about equipment and features are non-binding. The equipment features described in this planning manual are not considered to be the agreed quality of our products. For information on the products and product features currently available, please contact your local factory representative.

This documentation is updated regularly. Necessary corrections and appropriate supplements are always included in the following releases. You can also find the latest edition of the planning manual and current tender texts at www.inventer.de/downloads.

On request, we will be pleased to provide you with our inVENTer calculation tool for dimensioning.

All illustrations in the planning manual are only examples of applications. The illustrations and texts also contain components and accessories and special equipment which are not part of the standard scope of delivery.

In addition, always observe the regional regulatory stipulations. These may deviate completely or partially from the specifications given in this planning folder. In this case, the official stipulations always apply.

Technical Specifications

Unless otherwise stated, dimensions in illustrations are in millimetres. All technical data refer to new devices with clean heat accumulators. The technical data correspond to the norms and standards valid at the time of writing of this planning manual. A change of these standards or technical data due to component changes is possible at any time. This is checked regularly and taken into account in subsequent versions.

Table of Contents

| | Page |
|--|-------------|
| Information on Controlled Ventilation of Residential Spaces | |
| Controlled ventilation of Residential Spaces | 6 |
| Functionality | 8 |
| Standards for Decentralised Ventilation Planning | 10 |
| Ventilation according to DIN 1946-6 | 11 |
| Information for Energy Consultants | 13 |
| Technical Specifications | |
| Overview | 16 |
| Standard Sound Level Difference + Evaluated Sound Insulation Index | 20 |
| Assembly and installation Tools | 24 |
| iV Ventilation Systems with Heat Recovery | 27 |
| inVENTer iV-Smart+ | 28 |
| inVENTer iV-Smart+ Corner | 32 |
| inVENTer iV-Smart+ Sylt | 34 |
| inVENTer iV-Smart+ Top | 37 |
| inVENTer iV14-Zero | 40 |
| inVENTer iV14-Zero Corner | 42 |
| inVENTer iV-Twin+ | 44 |
| iV-Light | 46 |
| iV-Compact | 48 |
| inVENTer iV25 | 50 |
| inVENTer PAX (Recuperative system) | 52 |
| Overflow System USTS 100 Pulsar | 56 |
| Controller for inVENTer Ventilation Systems | 59 |
| sMove Controller | 60 |
| MZ-Home Controller | 62 |
| inVENTer Connect Controller System | 66 |
| aV Exhaust Air Systems without Heat Recovery | 71 |
| Wall Mounting Kit aV100 | 72 |
| Exhaust Air Unit Avio N 100 | 73 |
| Exhaust Air Unit Pulsar Basic | 74 |
| Exhaust Air Unit Pulsar | 75 |
| Exhaust Air Unit Aviant | 76 |
| Exhaust Air Unit Aventus | 77 |
| Fresh Air Diffuser aV100 ALD | 82 |
| Fresh Air Diffuser aV100 ALD Plus | 83 |
| Fresh Air Diffuser aV160 ALD Light | 84 |
| Fresh Air Diffuser aV160 ALD Plus | 85 |
| Accessories for inVENTer Products | 88 |
| Warranty Overview | 91 |



Information

Controlled Ventilation of Residential Spaces

Controlled Ventilation of Residential Spaces

For you, energy saving begins with the investment in good façade insulation, tight windows and tight doors in order to use heating energy efficiently and reduce energy consumption. The resulting sealed construction of the buildings does not only have advantages. Insulation in new buildings and also in renovated old buildings increasingly leads to damage in the building substance, as the buildings can no longer "breathe" properly. In addition to a poor indoor climate, high-density building claddings can also lead to mould growth.



An automatic ventilation system, e.g. from inVENTer, which automatically removes used air and supplies fresh air, ensures a healthy indoor climate. Thanks to the high heat recovery and low energy consumption, with the decentralised ventilation systems you can efficiently save valuable heating energy.

And even if there is no obvious mould growth or moisture damage, poor ventilation can still cause discomfort. Occupants present produce carbon dioxide, which must be removed and replaced by oxygen. Good air quality requires a continuous air exchange of 30 m³ per hour per person. A constant exchange of air is important because an excessively high CO₂ concentration can cause disorders such as poor concentration and headaches.

Used air not only reduces your performance, it is also bad for your health and well-being.

Decentralised Ventilation Systems

We often take the indoor climate at home or at work for granted. Although temperatures that are too high or too low are still consciously perceived, subjective perception is often not sufficient as an evaluation criterion even for humidity. Conventional window ventilation is often intended to provide a remedy here. But due to the stronger building insulation, this too is increasingly reaching its limits and in many cases is no longer sufficient. Decentralised systems for domestic ventilation offer a flexible alternative.



Reliable and proven effectiveness

Decentralised ventilation units, also known as alternating systems, are the most common form of decentralised home ventilation. Due to the many advantages in terms of installation, application and low maintenance, the demand for these systems has been rising continuously for years.

The EwWalt study was intended to gather further findings on alternating operation and was able to substantiate the basic functioning of the system. The ventilation efficiency was investigated on the basis of an elaborate simulation and under usual design variants on the basis of a room, an apartment and a single-family house. It was found that in all cases mixed ventilation was used regardless of the size of the room. Therefore, the ventilation effect is equal to other ventilation solutions.

The study illustrates the versatile application possibilities of alternating systems; they can be used effectively both in one room and in several rooms with overflow. The interaction with other floors (e.g. in a single-family house) is also confirmed.



The conventional window ventilation: A landlord cannot prescribe window ventilation because permanent airing is not the usual purpose of an apartment and is unreasonable for the tenant (several court rulings).



Installation in the Façade Wall

Decentralised ventilation systems can be easily inserted into the exterior wall both for renovations and for new buildings.

If the wall opening has been prepared, the installation per ventilation unit can be completed within less than 2 hours.

There is no need to install ducts or take special maintenance features into account.



Planning Together with Experts

Experience has shown that even for planners and architects who have not yet come into contact with decentralised ventilation systems, the design does not present a major obstacle. In the unlikely event of any ambiguities, our factory representatives and our in-house planning department will support you with practical planning services for the design of decentralised ventilation systems.

Functionality

A decentralised ventilation system is based on supply air movement between corresponding ventilation units. Decentralised ventilation systems combine exhaust and supply air and function according to the transverse ventilation principle. Thanks to the transverse ventilation principle, the air can circulate through the entire residential unit and also adequately ventilate interior living spaces. By specifically influencing air movement, humidity and air quality, the units contribute to structural protection and increased comfort in the living space.

Ventilation Units with Heat Recovery

The decentralised iV ventilation systems with heat recovery consist of ventilation units arranged in pairs. They always work in push-pull mode and automatically switch between exhaust and supply air mode in order to ensure balanced air volume flows.

Quiet as a whisper, the fan of your inVENTer unit rotates in one direction for 70 seconds, transporting the used air outside. The inner ceramic core stores the heat from the air inside.

Then, the direction of rotation changes. Fresh air from outside is absorbed, heated in the ceramic heat accumulator and released into the room. Valuable heating energy is used efficiently.

With appropriate inVENTer controllers, you may operate the iV ventilation systems intuitively. Different operating modes or the strength of the ventilation can be set individually. The key components of the iV system are the ceramic heat accumulator, the reversing fan, double air fins for straightening the air volume flow, filters for all hygienic requirements, a lockable inner screen and the powder-coated, rain-proof weather protection hood.



Exhaust air units supplement the decentralised ventilation units in damp rooms.

Exhaust Air Units and Air Vent Openings

Ventilation units with heat recovery can be supplemented with exhaust air units for the ventilation of rooms with moisture ingress (e.g. bathrooms, toilets). They work without heat recovery and can be designed for permanent or demand-driven operation. Humid room air and odours are led outside via the ventilation unit.

The additional exhaust air volume flows can be re-circulated via the decentralised units.

Alternatively, an exhaust air system without heat recovery with external air diffusers (ALDs) is also possible. The ALDs are installed in the supply air room, which forms a room network with the exhaust air unit. The resulting negative pressure causes the outside air to flow in automatically. The external air diffusers are equipped with a filter system to ensure the minimum hygienic requirements and are equipped with a wind protection as standard.



Exhaust air systems consist of exhaust air units and fresh air diffusers (ALDs).

Overflow Surfaces

An air connection between the individual rooms is created by suitable overflow measures within the residential unit. In order to ensure the exchange of air between the respective units, correspondingly large overflow openings must be considered.

The overflow can also be fan-assisted using overflow systems.

Their interaction ensures an optimal comfortable atmosphere in your home.

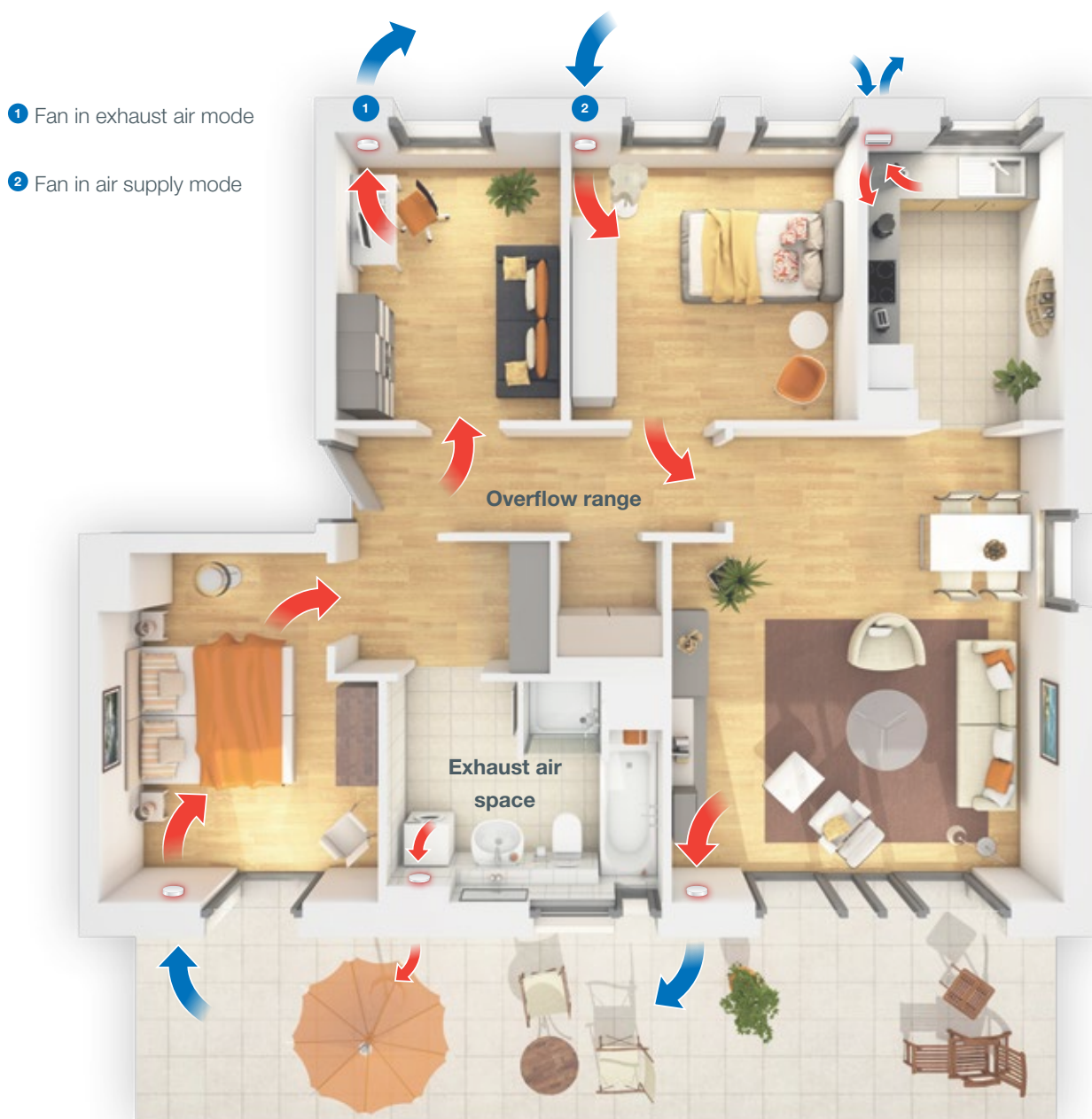

Standards for Decentralised Ventilation Planning

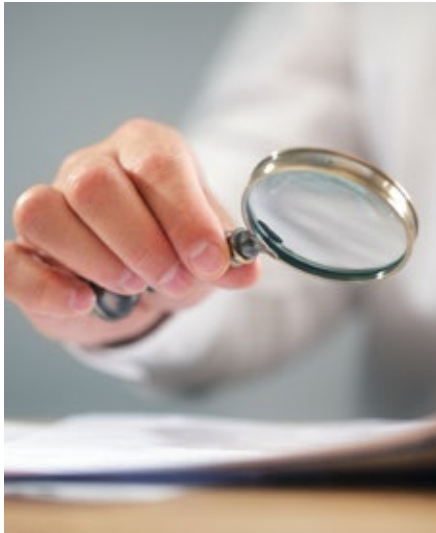

The standards and requirements listed in this planning manual represent relevant standards and guidelines in the Federal Republic of Germany and for the planning of decentralised ventilation systems at the time of publication only and are applicable at the time of printing. The list makes no claim to completeness and validity at a later date.

In addition, always observe the regional official regulations, e.g. the respective state building regulations. These may deviate completely or partially from the specifications given in this planning folder. In this case, the official stipulations always apply.

If outside Germany, observe the application of the respective country-specific standards and regulations.

Requirements for ventilation planning

DIN 1946-6:2009-05: Room air technology, ventilation of residences.

DIN 18017-3: Ventilation of windowless kitchens and bathrooms with fans

EN 13142: Room air technology: Ventilation of residences - Required and freely selectable power ratings.

DIN EN ISO 16890-1: Air filters for general ventilation technology - Determination of filter performance.

DIN EN 13141-8: Ventilation of buildings: Performance testing of components/products for the ventilation of residences.

DIN EN 15665: Ventilation of buildings. Determination of performance criteria for the design of ventilation systems in residential buildings.

Noise protection regulations

DIN EN 12102: Measurement of airborne acoustical noise emissions - Determination of the sound power level.

EN ISO 10140: Acoustics - Measurement of the sound insulation of components in the test bench.

DIN 4109: Noise protection in building construction.

Energy Saving Regulations

EEWärmeG: Act on the Promotion of Renewable Energies in the Heat Sector

EnEV: Renewable energy ordinance

DIN EN 12831: Heating systems in buildings - Method for calculating the standard heating load

DIN 4108-6: Thermal insulation and energy saving in buildings

DIN 4108-7: Thermal insulation and energy saving in buildings - Airtightness of buildings, requirements, planning and implementation recommendations.

DIN 4701-10: Energetic evaluation of heating and ventilation systems - heating, potable water heating, ventilation

DIN EN 16789: Energy efficiency of buildings.

Ventilation according to DIN 1946-6



Provisions of EnEV 2014

According to the Energy Saving Ordinance EnEV 2014, "Buildings to be erected (...) must be designed in such a way that the minimum air exchange required for health and heating purposes is ensured". (Art. 6.2). This minimum air exchange is specified for residential rooms in DIN 1946-6. Proof is provided by a ventilation concept in accordance with DIN 1946-6. This stipulates that for new buildings and energetic renovation of buildings, it must be checked whether a ventilation measure is necessary.

Basically, it can be said that ventilation measures are always necessary when the preservation of the building fabric cannot be covered by avoiding moisture through window ventilation as well as joints and leaks.

For new buildings, a ventilation concept is generally required.

A ventilation concept is required for renovation if:

- ☒ in a detached house more than 1/3 of the existing windows are replaced or more than 1/3 of the existing roof area is sealed,
- ☒ in an apartment building, more than 1/3 of the existing windows will be replaced.

inVENTer provides a free calculation tool for planning your new building or renovation. Our team supports you with practical planning services for the design and creation of a DIN-compliant ventilation concept.

Air types according to DIN 1946-6?



DIN 1946-6 distinguishes between four types of ventilation: Humidity protection ventilation, reduced ventilation, nominal ventilation and intensive ventilation.

In the case of fan-assisted ventilation, e.g. with the aid of inVENTer, however, the design must always be based on nominal ventilation. This takes both the protection of buildings and the hygienic and health requirements of the occupants into account.

Moisture protection ventilation is the basic ventilation to avoid moisture damage depending on the thermal insulation level of the building with partially reduced moisture loads. This level must be ensured constantly and without the participation of the users. If this cannot be guaranteed, a ventilation measure must be taken. The moisture protection ventilation only takes into account the protection of buildings, no hygienic requirements.

Nominal ventilation is the necessary ventilation to guarantee the hygienic and health requirements as well as building protection during normal use of the flat. The user can be consulted for this partly with active window ventilation.

A calculation example with the inVENTer calculation tool

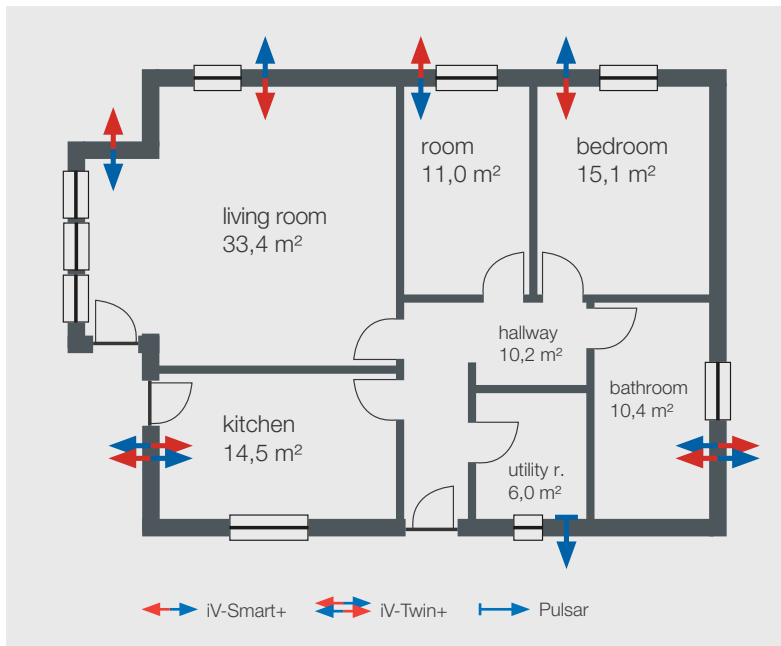

Example of a typical usage unit with energy evaluation, air volume flows and number of inVENTer devices required (example floor plan).

Energy evaluation

| | |
|--|---------|
| Heating energy $q_{L,g,WE,WRG}$ (kWh/m ² a) | 30.7 |
| Heating energy $q_{L,g,WE,WRG} - q_{h,n}$ (kWh/m ² a) (corr. acc. to table C.2-4) | 15.8 |
| Auxiliary energy $p_{a,Vent}$ (W/m ³ /h) | 0.15 |
| Auxiliary energy $q_{L,g,HE,WRG}$ (kWh/m ² a) | 1.09 |
| Heating energy/p.a.(kWh/a) | 1,951.6 |
| Auxiliary energy/p.a.(kWh/a) | 109.3 |
| (According to DIN 4701-10:2003-08) | |

Volume streams

| | AVF Nominal Total | AVF Nominal Unit | Config. Controller | AVF Actual Unit | AVF per person: |
|-------------------------------------|-------------------------|------------------------|-----------------------|-----------------------|--------------------|
| Humidity protection ventilation HPV | 37.7 | 24.4 | 25 % | 46.5 | 11.6 |
| Reduced ventilation RV | 87.9 | 74.7 | 45 % | 80.4 | 20.1 |
| Nominal ventilation NV | 125.6 | 112.4 | 65 % | 112.5 | 28.1 |
| Intensive ventilation IV | 163.2 | 150.0 | 90 % | 150.4 | 37.6 |

(Ventilation levels according to DIN 1946-6 q_v in m³/h)
AVF = Air Volume Flow

Summary

| | |
|--|-------|
| infiltration volume flow [m ³ /h] | 13.2 |
| Unit air volume flow [m ³ /h] | 165.0 |
| Total air volume flow [m ³ /h] | 178.0 |
| Total air volume flow / person [m ³ /h] | 44.3 |
| Max. air volume flow [m ³ /h] | 178.0 |
| System air exchange (1/h) | 0.65 |
| Heat supply level | 0.88 |

Information for Energy Consultants

KfW requirements
"Energy-efficient
construction."

By entering the factory data of the inVENTer ventilation in the calculation according to EnEV, you often achieve the requirements for a KfW-Effizienzhaus 70 in combination with a gas condensing boiler and thus exceed the requirements of the EEWärmeG. In all combinations of heat generators, we achieve all KfW efficiency house classes with inVENTer data, including the KfW efficiency house 40+, even with gas/oil condensing boiler.

Values for the iv-Smart+ in Hottgenroth (example)

The image displays two screenshots of the Hottgenroth ETU software interface, showing the configuration of a ventilation system for a KfW 40+ house. The interface is titled 'Energieberater Professional' and shows project details for 'Seminarbeispiel KfW 55' (DIN 4108-6/4701-10 - Wohngebäude).

Top Screenshot: Lüftungsanlage (Ventilation System) Settings

- Projekt:** Seminarbeispiel KfW 55, DIN 4108-6/4701-10 - Wohngebäude
- Gebäudedaten:** Nutzfläche An: 164,12 m²; Nutzenergiebedarf: 12,50 kWh/m²; Heizung: 30,85 kWh/m²; EnEV, feste HP: 185 Tage
- Lüftungsanlage:**
 - Typ: dezentrale Lüftungsanlage
 - Anlagen-Luftwechselrate: 0,40 1/h
 - belüfteter Flächenanteil: 100,0 %
 - belüftete Fläche: 164,1 m²
 - Verteilung: Ventilatoren, Wärmeübertrager
 - Stromversorgung: Gleichstrom (DC)
 - volumenbezogene Ventilatorleistung: 0,15 W/(m³/h)
 - Ergebnisse: Hilfsenergie Ventilatoren: 0,67 kWh/a
 - Luftwechsel-Korrektur: 0,0 kWh/a
 - Beitrag zum Heizwärmebedarf: 17,1 kWh/a

Callout Box (Top): For the iv-Smart+, enter a volume-related fan output of 0.15. Power is supplied via direct current.

Bottom Screenshot: Wärmeerstellungsgrad (Heat Supply Degree) Settings

- Wärmeerstellungsgrad:** 87,8 %
- Ergebnisse: Jahres-Heizarbeit des Wärmeübertragers: 16,5 kWh/a
- Luftwechsel-Korrektur: 0,0 kWh/a
- Beitrag zum Heizwärmebedarf: 16,5 kWh/a

Callout Box (Bottom): You achieve a KfW efficiency house 40+. The degree of heat supply is 87%. No frost protection function is required, intermittent frost protection operation is correct here.



Technical Specifications

of the inVENTer system in overview

Overview of the technical specifications

Ventilation Systems



| | iV-Smart+ COMPACT FAN | iV-Smart+ Corner CONCEALED OUTER TERMINATION | iV-Smart+ Sylt UNDER GROUND LEVEL | iV-Smart+ Top IN THE ROOF | iV-Compact THIN WALLS |
|---|---------------------------------|---|---|-------------------------------------|---------------------------------|
| Wall opening [mm] | Ø 180 | Ø 180 | Ø 180 | Ø 180 | Ø 180 |
| Wall thickness with plaster [mm] | > 270 | > 270/>70 insulation | > 270 | > 270 | > 140 |
| Air volume flow [m³/h] | 8.5 - 29 | 8.5 - 29 | 8.5 - 29 | 8.5 - 29 | 10.5 - 29 |
| Exhaust air volume flow [m³/h] | 17 - 58 | 17 - 58 | 17 - 58 | 17 - 58 | 21 - 58 |
| Power consumption [W] | 3 | 3 | 3 | 3 | 3 |
| Sound pressure level [dB (A)] | 21 - 36 | 21 - 36 | 21 - 36 | 21 - 36 | 21 - 44 |
| Heat recovery [%] | 87 | 87 | 87 | 87 | 72 |
| Volume flow related electr. Fan output [W/(m³/h)] | 0.15 | 0.15 | 0.15 | 0.15 | 0.13 |
| Weather protection hood [WxH, mm] | 222 x 285 / 279 x 313 | 70 x 512 | Ø 159 x H 880 | Ø 265 x H 380 | 203 x 276 |
| Inner cover [WxH,mm] | 233 x 233 | 233 x 233 | 233 x 233 | 233 x 233 | 233 x 233 |
| Operating temperature [°C] | -20 - 50 | -20 - 50 | -20 - 50 | -20 - 50 | -20 - 50 |
| Standard sound level difference [dB]¹ | 38 - 49 | 53 - 59 | -- | 41 - 45 | 32 |
| Energy efficiency class | A+ / A | A+ / A | A+ / A | A+ / A | A |

¹) depending on sound insulation accessories, further information see noise tables page 20 seq.

Ventilation Systems



| | iV14-Zero SOUND INSULATION FAN | iV14-Zero Corner CONCEALED OUTER TERMINATION | iV-Twin+ SINGLE ROOM FAN | iV-Light BASIC FAN | iV25 FOR SPACIOUS ROOMS |
|---|---|---|------------------------------------|------------------------------|-----------------------------------|
| Wall opening [mm] | Ø 225 | Ø 225 | Ø 225 | Ø 180 | Ø 270 |
| Wall thickness with plaster [mm] | > 255 | > 270/> 70 Insulation | > 270 | > 290 | > 270 |
| Air volume flow [m³/h] | 8.5 - 29 | 8.5 - 29 | 5 - 23 | 5 - 21 | 23.5 - 55 |
| Exhaust air volume flow [m³/h] | 17 - 58 | 17 - 58 | 10 - 45 | 10 - 42 | 47 - 110 |
| Power consumption [W] | 3 | 3 | 3 | 3 | 2 - 5 |
| Sound pressure level [dB (A)] | 13 - 29 | 13 - 29 | 20 - 44 | 18 - 36 | 29 - 47 |
| Heat recovery [%] | 87 | 87 | 94 | 84 | Ø 72 / max. 77 |
| Volume flow related electr. Fan output [W/(m³/h)] | 0.15 | 0.15 | 0.16 | 0.2 | up to 0.16 |
| Weather protection hood [WxH, mm] | 279 x 313 | 70 x 512 | 279 x 313 | Ø 200 | 279 x 313 |
| Inner cover [WxH,mm] | 233 x 233 | 233 x 233 | 233 x 233 | 220 x 220 | Ø 290 |
| Operating temperature [°C] | -20 - 50 | -20 - 50 | -20 - 50 | -20 - 50 | -20 - 50 |
| Standard sound level difference [dB]¹ | 48 - 56 | 55 - 60 | 45 - 56 | 34 - 47 | 35 - 44 |
| Energy efficiency class | A+ / A | A+ / A | A+ / A | A+ / A | A / B |

¹) depending on sound insulation accessories, further information see noise tables page 20 seq.

Controller

**Controller
sMove s4**
FOR 4 UNITS

**Controller
sMove s8**
FOR 8 UNITS

MZ-Home Controller

FOR 16 UNITS IN 4 VENTILATION ZONES

Control unit MZ-Home
Clust-Air-Modul

| | | | | |
|-----------------------------|------------|------------|------------------------------|----------|
| Mains voltage [V AC], [Hz]: | 230, 50 | 230, 50 | 230, 50 | -- |
| Input voltage [V DC]: | 24 | 24 | 24 | 24 |
| Fan voltage [V DC]: | 6.7 - 15.3 | 6.7 - 15.3 | -- | 6 - 16 |
| External input [V DC]: | 0 - 10 | 0 - 10 | -- | 0 - 10 |
| Total breaking current [A] | -- | -- | -- | max. 0.8 |
| Power consumption [W] | max. 11 | max. 20 | max. 0.5 | max. 18 |
| Standby [W] | < 1 | < 1 | 1.5 (1 zone) – 2.5 (4 zones) | |
| Protection class | II | II | II | |

 Recuperative
System

inVENTer PAX
VENTILATION IN
MICRO APARTMENTS

| | |
|--------------------------------------|--|
| Air volume flow [m³/h] | 30 – 78 (90 exhaust air) |
| Heat recovery [%] | Ø 77 / max. 80 |
| Power consumption [W] | 3.5 - 25 |
| Preheating coil [W] | < 375 |
| Sound pressure level [dB (A)] | 19 - 29 (35 exhaust air max.) |
| Operating voltage [V AC],[Hz] | 230, 50 |
| Protection class | 24 |
| Filter fresh / exhaust air | G4/G4 |
| Standard sound level difference [dB] | 47 exhaust air space 77 air inlet space |
| Energy efficiency class | A |

inVENTer Connect Controller System

 Inner cover
Connect

| | |
|---|---------------------------------|
| Dimensions of inner panel [W x H, mm] | 258 x 258 |
| Installation depth flush-mounted version [mm] | + 38 |
| Radio frequency [MHz] | 868 |
| Radio network range | Open field: 100 Building: 30 |
| Mains voltage [V AC]/[Hz]: | 230/50 |
| Operating voltage [V DC] | 24 |
| Fan bus output voltage controller [V DC] | 6.7 - 15.3 |
| Power consumption [W] | 12 |
| Protection Type / Protection Class | IP 52 / II |

 Controller Easy
Connect e16

| | |
|---|---------------------------------|
| Dimensions control unit [W x H x D, mm] | 88 x 88 x 9 |
| Radio frequency [MHz] | 868 |
| Radio network range | Open field: 100 Building: 30 |
| Mains voltage [V AC]/[Hz]: | 230/50 |
| Operating voltage [V DC] | 24 |
| Power consumption [W] | 1.5 |

Overview of the technical specifications

Exhaust air fans



Avio N 100

TRACKING

CONTROL

Pulsar Basic / Pulsar

APP CONTROL

Aviant

SENSOR TRIO:
DAMP, LIGHT, ODOUR

Aventus

VENTILATION
DIN 18017-3

| | | | | |
|----------------------------------|-------------------|-------------------|-------------------|-------------------|
| Wall opening [mm] | Ø 115 (aV100) | Ø 115 (aV100) | Ø 115 (aV100) | |
| Wall thickness with plaster [mm] | > 180 (aV100) | > 180 (aV100) | > 180 (aV100) | |
| Exhaust air volume flow [m³/h] | 75 | 110 | 95 | max. 100 |
| Power consumption [W] | 6.4 | 4 | 2 - 5 | 7 - 24 |
| Sound pressure level [dB (A)] | 28 | 17 - 20 | 17 - 20 | 30 - 46 |
| Inner panel [mm] | 159 x 159 | Ø 177 | 182 x 157 | 260 x 260 |
| Weather protection cover [mm] | 154 - 157 (aV100) | 154 - 157 (aV100) | 154 - 157 (aV100) | 154 - 157 (aV100) |
| Protection class | II | II | II | II |
| Protection class | IPX4 | IP44 | IP44 | IPX5 |

Fresh air diffusers



aV100 ALD

BASIS-ALD

aV100 ALD Plus

EXTERNAL METALL HOOD

aV100 ALD Corner

CONCEALED
OUTER TERMINATION

aV160 ALD Light

SOUND INSULATION
ALD
UGRADABLE TO IV-
LIGHT

aV160 ALD Plus

SOUND INSULATION
ALD
UGRADABLE TO
IV-SMART+

| | | | | | |
|--------------------------------------|-----------|-----------|------------------------|-----------|-----------|
| Wall opening [mm] | Ø 115 | Ø 115 | Ø 115 | Ø 180 | Ø 180 |
| Wall thickness with plaster [mm] | > 150 | > 150 | > 150 / >70 insulation | > 150 | > 150 |
| Air volume flow [m³/h] | 7 - 15 | 7 - 15 | 7 - 15 | 12 - 18 | 13 - 17 |
| Air volume flow 8 Pa [m³/h] | 14 - 22 | 14 - 22 | 14 - 22 | 18 - 24 | 19 - 23 |
| Standard sound level difference [dB] | 33 - 49 | 34 - 48 | 55 - 59 | 51 - 52 | 54 - 55 |
| Inner panel [mm] | 160 x 160 | 160 x 160 | 160 x 160 | 180 x 180 | 180 x 180 |
| Weather protection cover [mm] | 150 x 150 | 154 x 157 | 104 x 282 | Ø 200 | 279 x 313 |

Values standard sound level difference $D_{n,e,w}$ and assessed sound insulation factor R_w

| Ventilation unit | Unit configuration | $D_{n,e,w}$ | R_w | A |
|--|--|--------------|----------------|----------------------------|
| iV ventilation systems | | | | |
| iV-Smart+ | Standard 1¹ | 38 dB | 11.0 dB | 0.020 m² |
| | Standard 1 + sound insulation insert | 43 dB | 16.0 dB | |
| | Standard 1 + SPR | 43 dB | 16.0 dB | |
| | Standard 1 + SPR + sound insulation insert | 46 dB | 19.0 dB | |
| | Standard 2² | 41 dB | 11.0 dB | 0.020 m² |
| | Standard 2 + sound insulation insert | 47 dB | 20.0 dB | |
| | Standard 2 + SPR | 46 dB | 19.0 dB | |
| iV-Smart+ Corner | Standard³ | 53 dB | 26.0 dB | 0.020 m² |
| | Standard + sound insulation insert | 55 dB | 28.0 dB | |
| | Standard + SPR | 57 dB | 30.0 dB | |
| | Standard + SPR + sound insulation insert | 59 dB | 32.0 dB | |
| iV-Smart+ Top | Standard⁴ | 41 dB | 14.0 dB | 0.020 m² |
| | Standard + sound insulation insert | 43 dB | 16.0 dB | |
| | Standard + SPR | 43 dB | 16.0 dB | |
| | Standard + SPR + sound insulation insert | 45 dB | 18.0 dB | |
| iV14-Zero | Standard⁵ | 48 dB | 23.0 dB | 0.031 m² |
| | Standard + sound insulation insert | 52 dB | 27.0 dB | |
| | Standard + SPR | 54 dB | 29.0 dB | |
| | Standard + SPR + sound insulation insert | 56 dB | 31.0 dB | |
| iV14-Zero Corner | Standard⁶ | 55 dB | 30.0 dB | 0.031 m² |
| | Standard + sound insulation insert | 57 dB | 32.0 dB | |
| | Standard + SPR | 59 dB | 34.0 dB | |
| | Standard + SPR + sound insulation insert | 60 dB | 35.0 dB | |
| iV-Light | Standard⁷ | 34 dB | 7.0 dB | 0.020 m² |
| | Standard + sound insulation insert | 41 dB | 14.0 dB | |
| | Standard + SPR | 41 dB | 14.0 dB | |
| | Standard + SPR + sound insulation insert | 47 dB | 20.0 dB | |
| iV-Compact | Standard⁸ | 32 dB | 5.0 dB | 0.020 m² |
| iV-Twin+ | Standard⁹ | 45 dB | 20.0 dB | 0.032 m² |
| | Standard + sound insulation insert | 52 dB | 27.0 dB | |
| | Standard + SPR | 53 dB | 28.0 dB | |
| | Standard + SPR + sound insulation insert | 56 dB | 31.0 dB | |
| iV25 | Standard¹⁰ | 35 dB | 11.9 dB | 0.049 m² |
| | Standard + sound insulation insert | 38 dB | 14.9 dB | |
| | Standard + SPR | 41 dB | 17.9 dB | |
| | Standard + SPR + sound insulation insert | 42 dB | 18.9 dB | |
| Recuperative ventilation system | | | | |
| inVENTer PAX | Main module (exhaust air space) | 47 dB | 28.0 dB | 0.121 m² |
| | Main module + silencer D100 + spiral duct D100 + poppet valve (supply air space) | 77 dB | 46.0 dB | 0.008 m ² |

| Ventilation unit | Unit configuration | Dn,e,w | Rw | A |
|---------------------------------------|------------------------------------|--------|---------|----------------------|
| aV exhaust air systems | | | | |
| aV100 Wall mounting kit | Standard ¹¹ | 29 dB | -2.0 dB | 0.008 m ² |
| aV100 Wall Mounting Kit Corner | Standard ¹² | 53 dB | 22.0 dB | |
| Fresh air diffusers ALD | | | | |
| aV100 ALD | Standard ¹³ | 33 dB | 2.0 dB | 0.008 m ² |
| | Standard + sound insulation insert | 49 dB | 18.0 | |
| aV100 ALD Plus | Standard ¹⁴ | 34 dB | 3.0 dB | 0.008 m ² |
| | Standard + sound insulation insert | 48 dB | 17.0 dB | |
| aV100 ALD-Corner | Standard ¹⁵ | 55 dB | 24.0 dB | 0.008 m ² |
| | Standard + sound insulation insert | 59 dB | 28.0 dB | |
| aV160 ALD Light | Standard ¹⁶ | 51 dB | 24.0 dB | 0.020 m ² |
| | Standard + flicker filter | 52 dB | 25.0 dB | |
| aV160 ALD Plus | Standard ¹⁷ | 54 dB | 27.0 dB | 0.020 m ² |
| | Standard + flicker filter | 55 dB | 28.0 dB | |
| aV160 ALD-Corner | Standard ¹⁸ | 61 dB | 34.0 dB | 0.020 m ² |

- 1 iV-Smart+ in configuration with inner panel Flair SDE and weather protection hood Smart
- 2 iV-Smart+ in configuration with inner panel Flair SDE and weather protection hood Flex
- 3 iV-Smart+ Corner in configuration with inner panel Flair SDE and flat channel Corner with soffit grid
- 4 iV-Smart+ in configuration with inner panel Flair SDE and weather protection hood Top
- 5 iV-Smart+ in configuration with inner panel Flair Zero and weather protection hood Flex Zero
- 6 iV-Smart+ Corner in configuration with inner panel Flair Zero and flat channel Corner with soffit grid
- 7 iV-Light in configuration with Light inner screen and Light weather protection grille
- 8 iV-Compact in configuration with inner panel Flair SDE and weather protection hood Compact
- 9 iV-Twin+ in configuration with inner panel Flair Twin+ and weather protection hood Flex Twin+
- 10 iV-Smart+ in configuration with inner panel Classic and weather protection hood Flex

- 11 aV100 Wall mounting set in configuration with exhaust air unit and weather protection hood aV100
- 12 aV100 Wall mounting set in configuration with exhaust air unit and flat duct corner with soffit grille
- 13 aV100 ALD in configuration with ALD insert incl. inner panel and weather protection grille aV100
- 14 aV100 ALD in configuration with ALD insert incl. inner cover and weather protection hood aV100
- 15 aV100 ALD in configuration with ALD insert incl. inner panel and flat duct corner with soffit grille
- 16 aV160 ALD in configuration with ALD insert incl. inner panel and weather protection grille Light
- 17 aV160 ALD in configuration with ALD insert incl. inner cover and weather protection hood Flex
- 18 aV160 ALD in configuration with ALD insert incl. inner panel and flat duct corner with soffit grille



Assembly and Installation Tools

for Ventilation Units

Wall mounting system Simplex

Wall installation system for the decentralised ventilation systems iV-Smart+, iV14-Zero, iV-Twin+, iV-Light, iV-Compact and aV100/ aV160 ALDs in their variants. Used in new buildings for quick installation. Consisting of installation block and pre-installed wall installation sleeve as a unit. Integration into the brickwork in the shell. Installed wall installation sleeve replaces core hole drilling and installation of the wall installation sleeve.

Made-to-measure ex works according to customer-specific wall construction.

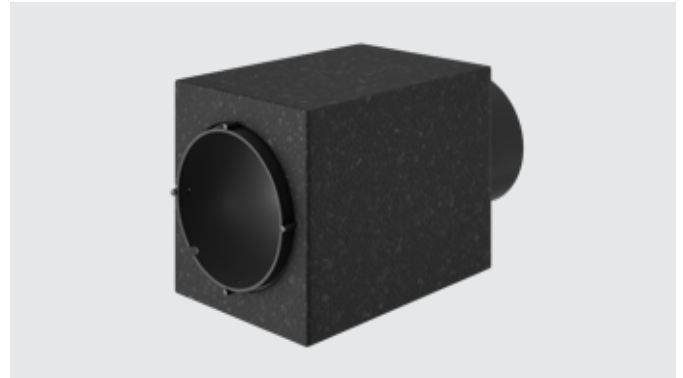

Technical Specifications

| | |
|--|---|
| Dimensions of mounting block [W x H, mm] | 260 x 249 |
| Diameter of wall mounting sleeve [mm] | iV-Smart+, iV-Light, iV-Compact, aV160 ALD: 160 |
| | iV14-Zero / iV-Twin+: 200 |
| | aV100 / aV100 ALD: 103 |
| Material | Neopor® |
| Reaction to fire | |
| DIN 4102: | B1: flame retardant |
| EN-ISO | 1 |
| Minimum distances from centre axis | |
| circumferential to other components | 250 mm |
| to other air openings | 1.2 m |
| frontal in the interior | 300 mm |

Features

- Individually adapted wall mounting block with optimised thermal insulation of specific thermal conductivity
- Wall mounting sleeve permanently installed in the installation block with integrated slope to condensate drain
- RAL-compliant installation with sound decoupling
- Structure open to diffusion on the outside and tight to diffusion on the inside
- The height of the installation block corresponds to the standard brick dimension of 249 mm.
- Recesses on outer sides for extra secure hold in masonry
- Fire behaviour: flame retardant (DIN 4102-B1)

Installation diagram wall installation system Simplex Connect

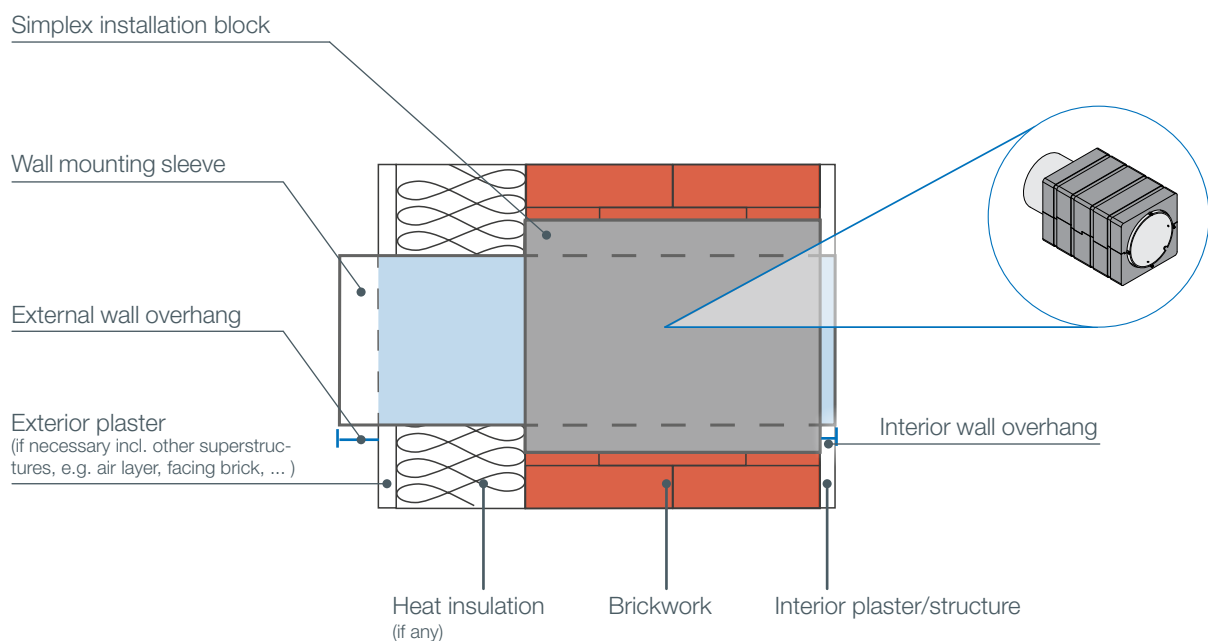

Wall installation system Simplex Connect

Wall installation system for the decentralised ventilation systems iV-Smart+ and iV14-Zero in connection with the controller platform inVENTer Connect. For new buildings with flush-mounted inner panel for quick installation. Consisting of mounting block, housing inner panel Connect and pre-installed wall mounting sleeve as a unit. Integration into the brickwork in the shell. Installed wall mounting sleeve replaces core hole drilling and mounting of wall mounting sleeve and housing.

Made-to-measure ex works according to customer-specific wall construction.

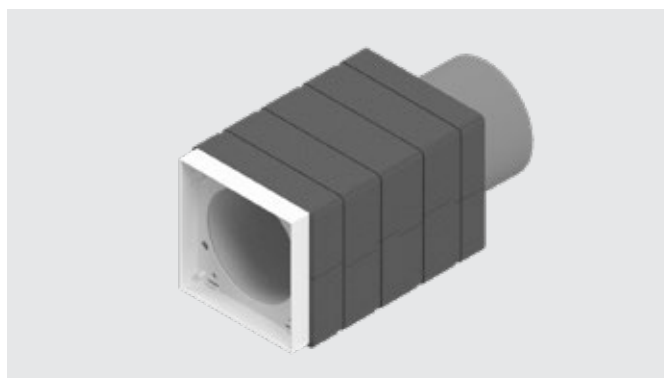

Technical Specifications

| | |
|--|----------------------------------|
| Dimensions of mounting block [W x H, mm] | 260 x 249 |
| Diameter of wall mounting sleeve [mm] | IV-SMART+: 160 iV14-Zero: 200 |
| Material | Neopor®, PPs |
| Reaction to fire | |
| DIN 4102: | B1: flame retardant |
| EN-ISO | 1 |
| Minimum distances from centre axis | |
| circumferential to other components | 250 mm |
| to other air openings | 1.2 m |
| frontal in the interior | 300 mm |

Features

- Individually adapted wall mounting block with optimised thermal insulation of specific thermal conductivity
- Wall mounting sleeve permanently installed in the installation block with integrated slope to condensate drain
- RAL-compliant installation with sound decoupling
- Structure open to diffusion on the outside and tight to diffusion on the inside
- The height of the installation block corresponds to the standard brick dimension of 249 mm.
- Recesses on outer sides for extra secure hold in masonry
- Fire behaviour: flame retardant (DIN 4102-B1)

Installation diagram wall installation system Simplex Connect

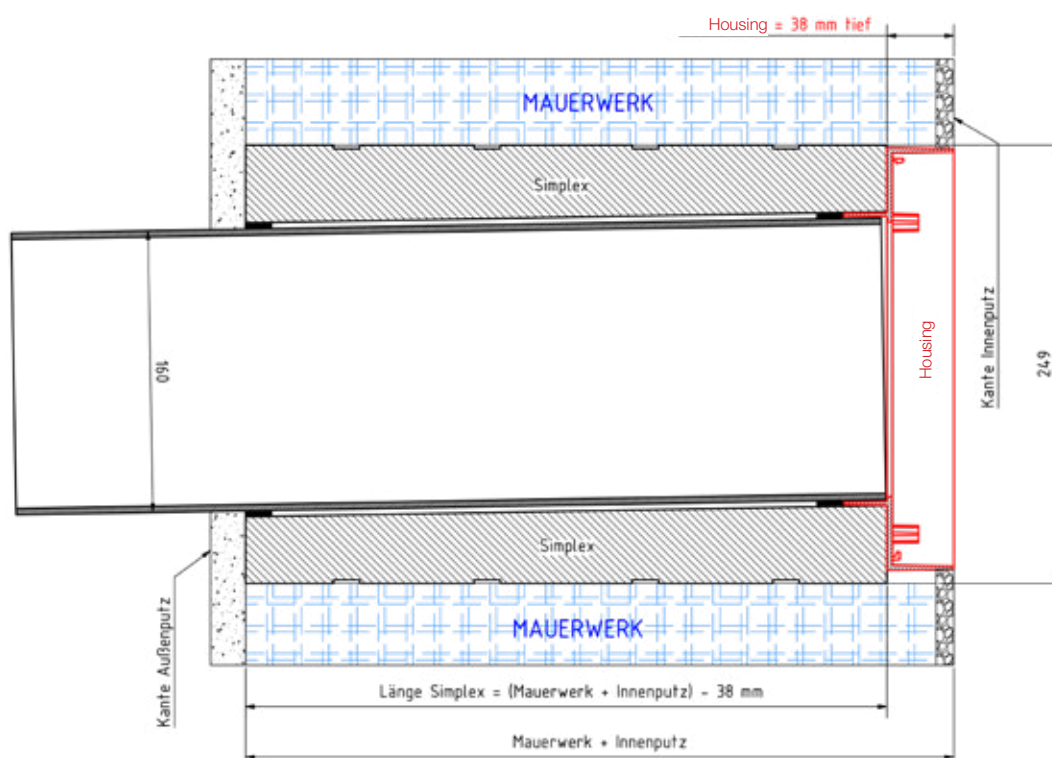

Wall mounting block WEB

Wall mounting block WEB D120



Installation kit for the exhaust air system aV100. Replaces core drill hole for the aV100 wall installation set / aV100 ALD For new buildings. Integration into the brickwork in the shell.

Features

- Wall mounting block with optimized specific thermal conductivity
- Recesses on outer sides for extra secure hold in masonry
- Trunnion system for combining individual blocks for required wall thickness
- Depth per wall mounting block 120 mm, can be shortened individually
- Fire behaviour: flame retardant (DIN4102-B1)

| | |
|----------------------------|-----------------|
| Material | Neopor® |
| Dimensions [W x H x D, mm] | 210 x 249 x 120 |
| Internal opening [Ø, mm] | 120 |

Wall mounting block WEB D180



Installation aid for the decentralised ventilation system iV-Smart+, iV-Light, iV-Compact, aV160 ALD. Replaces the core hole for the wall mounting sleeve Ø 160 mm. For new buildings. Integration into the brickwork in the shell.

Features

- Wall mounting block with optimized specific thermal conductivity
- Recesses on outer sides for extra secure hold in masonry
- Trunnion system for combining individual blocks for required wall thickness
- Depth per wall mounting block 120 mm, can be shortened individually
- Fire behaviour: flame retardant (DIN4102-B1)

| | |
|----------------------------|-----------------|
| Material | Neopor® |
| Dimensions [W x H x D, mm] | 210 x 249 x 120 |
| Internal opening [Ø, mm] | 180 |

Wall mounting block WEB D230



Installation accessory for the decentralised ventilation system iV14-Zero / iV14-Zero Corner / iV-Twin+. Replaces core drill hole for wall mounting sleeve Ø 200 mm. For new buildings. Integration into the brickwork in the shell.

Features

- Wall mounting block with optimized specific thermal conductivity
- Combination of individual blocks for required wall thickness
- Depth per wall mounting block 365 mm, can be shortened individually
- Fire behaviour: flame retardant (DIN4102-B1)

| | |
|----------------------------|-----------------|
| Material | Neopor® |
| Dimensions [W x H x D, mm] | 280 x 280 x 365 |
| Internal opening [Ø, mm] | 230 |

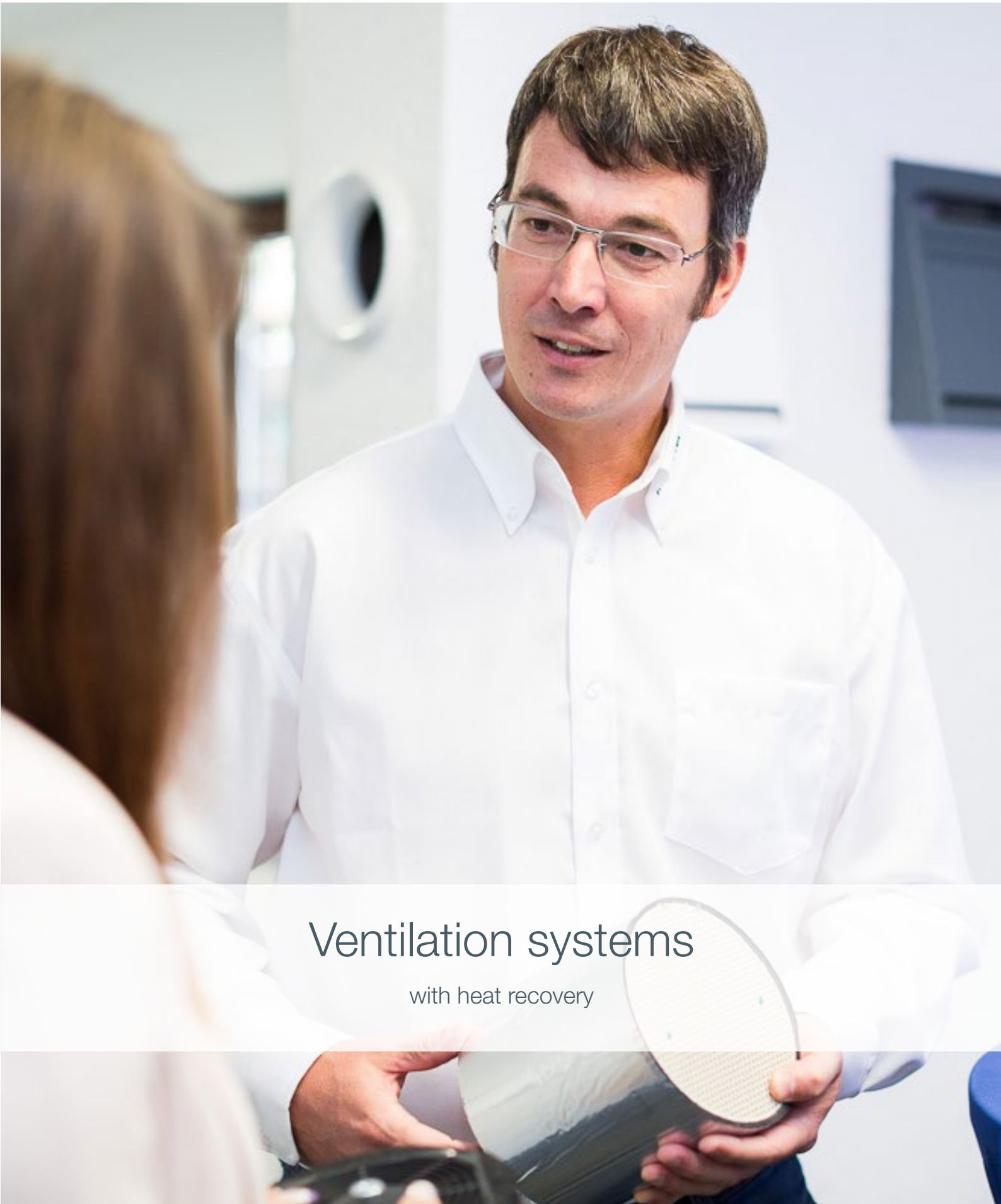

Ventilation systems

with heat recovery

inVENTer iV-Smart+



iV-Smart+ inside complete system

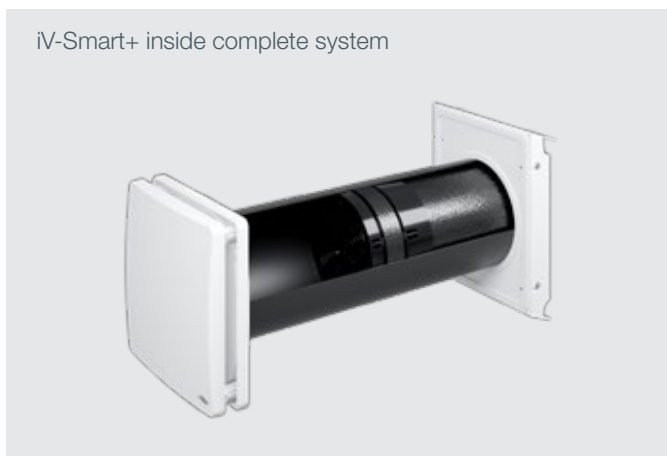

Decentralised ventilation system with heat recovery.
5-year manufacturer's warranty. Compact unit for new construction and renovation for easy integration in exterior walls.
External control via controller.

Quick installation with Simplex: Installation block with pre-installed wall installation sleeve, integrated slope.

Minimal operating costs thanks to low power consumption of 3 W and the possibility of user maintenance.

Components

- Insert with ceramic honeycomb heat accumulator
- inVENTron®: Xenion® reversing fan with temperature monitor and wind pressure stabilizer, embedded in double air fin for flow rectification. Fan meets S3 classification according to DIN EN 13141-8.
- Internal screen with filter G4, wall mounting sleeve, driving-rain proof weather protection hood

Controller

- MZ-Home, sMove s4/s8, controller system inVENTer Connect

Accessories (optional)

- Pollen filter F5, activated carbon filter
- Wall mounting block D180 or Simplex R-D160
- Sound and wind protection accessories

External cover iV-Smart+

Weather protection hood Smart (lh) or Flex (rh)



White: RAL9016
Grey: RAL9006
North: RAL7011
Anthracite: RAL7016

Inner cover iV-Smart+:

Flair (RAL9010)



Technical Specifications

| | | | |
|---|------------------------|---|--------|
| Heat recovery [%] | 87 | Minimum wall thickness [mm] | 270 |
| Air volume flow per unit [m³/h] | 8.5 - 29 | Diameter of wall opening [mm] | 180 |
| Exhaust air volume flow per unit [m³/h] | 17 - 58 | Diameter of wall mounting sleeve [mm] | 160 |
| Sound pressure level [dB (A)], distance 1 m | 21 - 36 | Power consumption [W] | 3 |
| Standard sound level difference $D_{n,e,w}$ [dB] | 38 - 49 | Volume flow rel. power consumption [W/(m³/h)] | 0.15 |
| Dimensions inner cover Flair [W x H, mm] | 233 x 233 | Protection class | IP20 |
| Dimensions of weather protection hood [W x H, mm] | 222 x 285 279 x 313 | Input voltage [V DC]: | 6 - 16 |
| | | Energy efficiency class | A+ / A |

Installation diagram iV-Smart+ with weather protection cover Smart

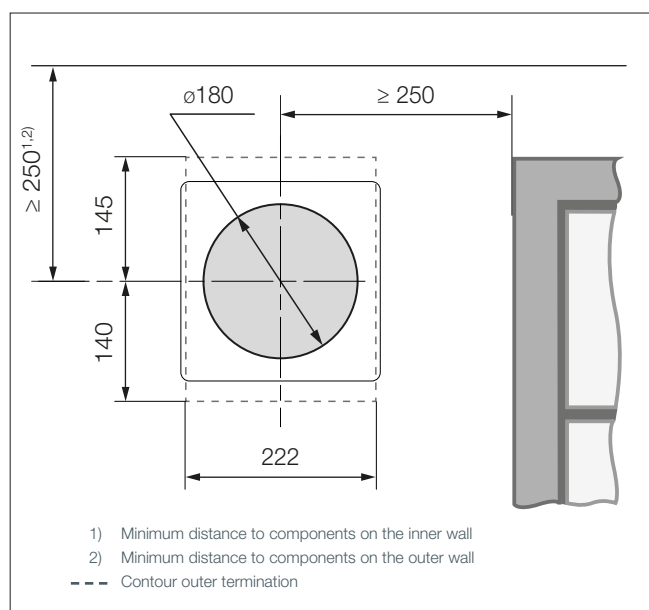
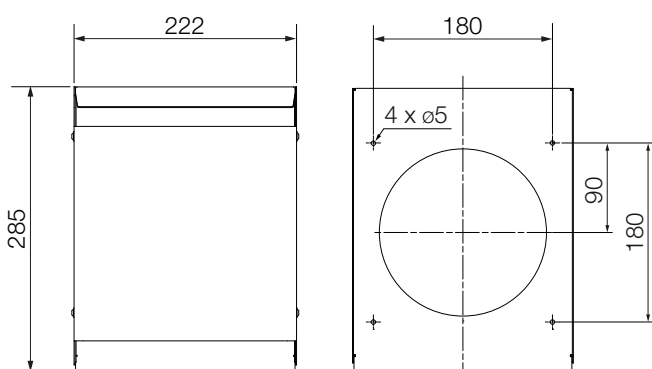
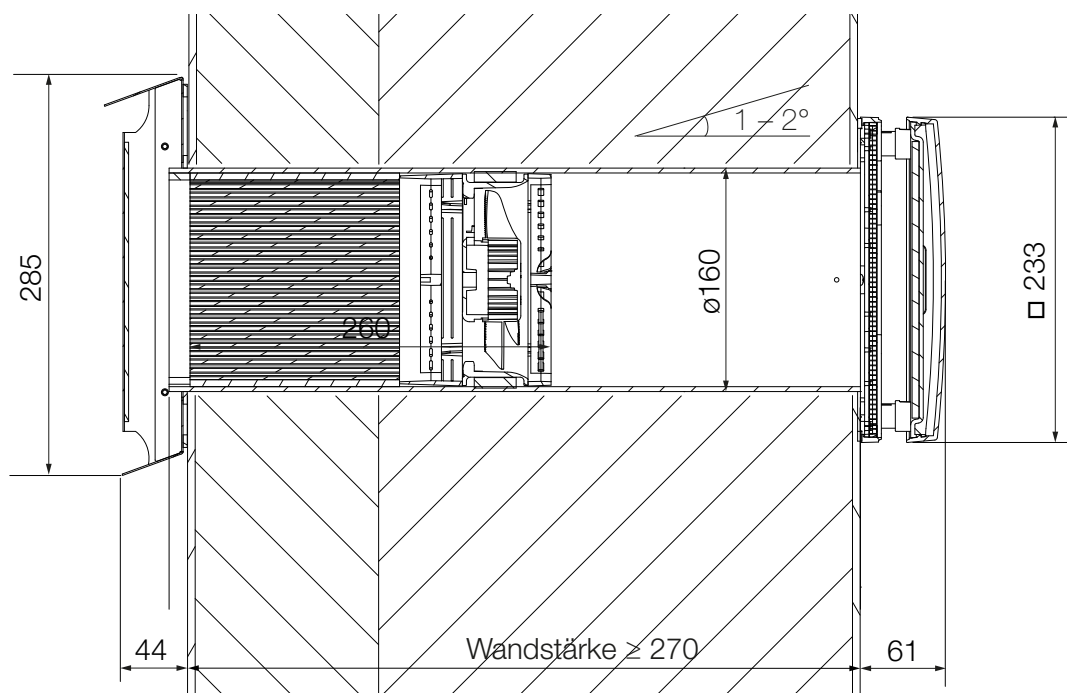

Remarks

To ensure that the system can be installed, observe the minimum clearances shown in the adjacent illustration.

Minimum wall thickness: 270 mm.

Minimum distances from centre axis core bore

- to components on the inner wall/loib: 250 mm circumferential

- to components on the outer wall 250 mm circumferential

Mind lintels, reveal edges, insulation thickness and possible roller shutters.

- between two ventilation units in the same room: 1.2 m.
- to other ventilation systems in the external area: 1.2 m.
- mount in the air volume flow of the room at approx. 1.80 m OKFFB optimally.
- For a better appearance on the façade, attach the upper edge of the weather protection hood at the height of the lower edge of the lintel..

All assembly and operating instructions as well as further information can be found at www.inventer.de.



DXF / DWG / STP

Installation diagram iV-Smart+ with weather protection cover Flex

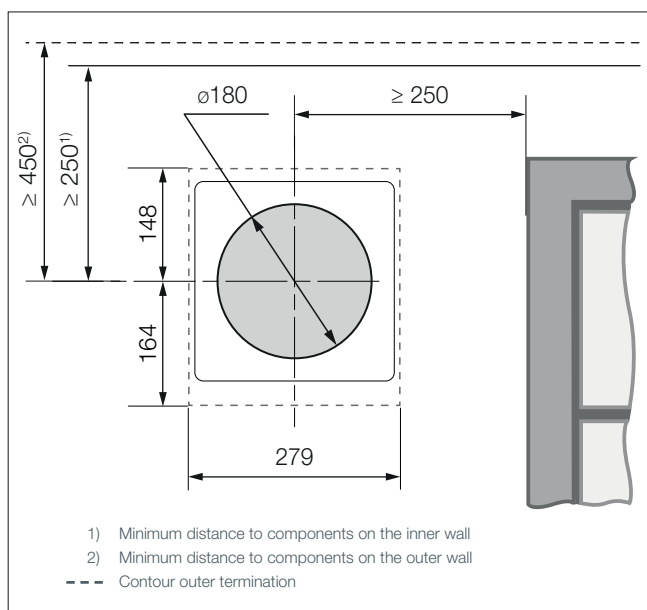
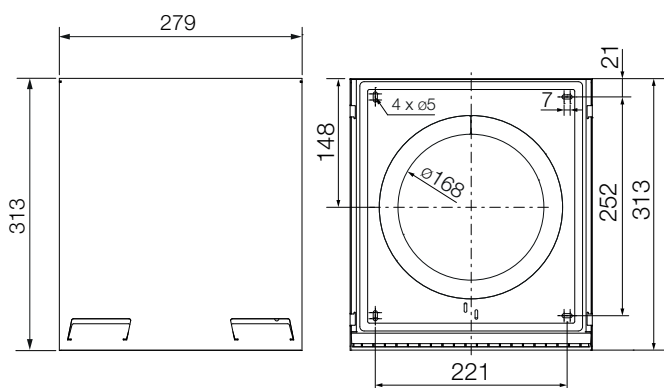
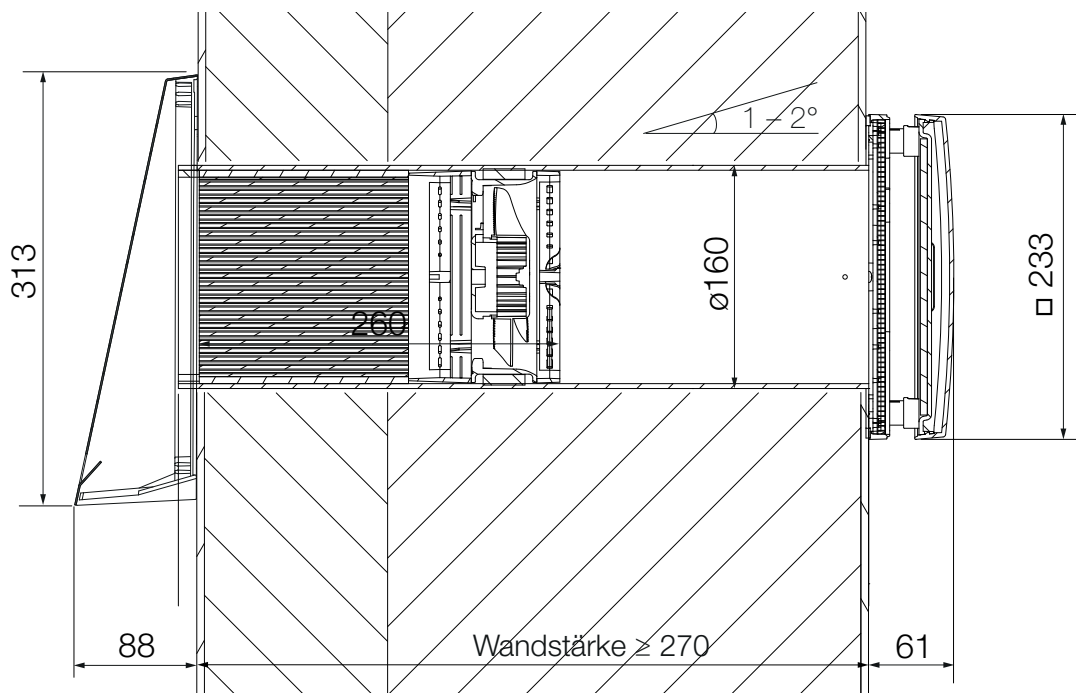

Remarks

To ensure that the system can be installed, observe the minimum clearances shown in the adjacent illustration.

Minimum wall thickness: 270 mm.

Minimum distances from centre axis core bore

- to components on the inner wall/loib: 250 mm circumferential
- to components on the outer wall
 - 250 mm laterally/ downwards,
 - 450 mm upwards,

Mind lintels, reveal edges, insulation thickness and possible roller shutters.

- between two ventilation units in the same room: 1.2 m.
- to other ventilation systems in the external area: 1.2 m.
- mount in the air volume flow of the room at approx. 1.80 m OKFFB optimally.
- Recommendation: For a better appearance on the façade, attach the upper edge of the weather protection hood at the height of the lower edge of the lintel..

All assembly and operating instructions as well as further information can be found at www.inventer.de.



DXF / DWG / STP

inVENTer iV-Smart+ Corner

iV-Smart+ inside complete system

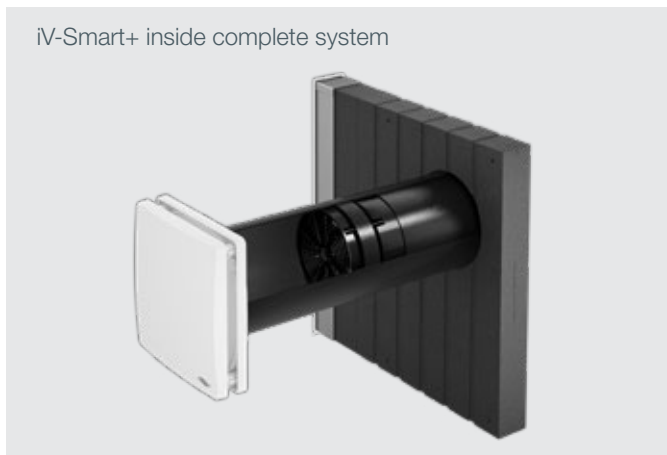

Decentralised ventilation system with heat recovery. 5-year manufacturer's warranty. Compact unit for new construction and renovation as reveal variant with concealed external finish for easy integration into external walls with external wall insulation.

External control via controller.

Minimal operating costs thanks to low power consumption of 3 W and the possibility of user maintenance.

Quick installation with Simplex: Installation block with pre-installed wall installation sleeve, integrated slope.

Components

- Insert with ceramic honeycomb heat accumulator
- inVENTron®: Xenion® reversing fan with temperature monitor and wind pressure stabilizer, embedded in double air fin for flow rectification. Fan meets S3 classification according to DIN EN 13141-8.
- Internal screen with filter G4, wall mounting sleeve,
- Flat channel Corner with integrated slope (incl. reveal grille)

Controller

- MZ-Home, sMove s4/s8, controller system inVENTer Connect

Accessories (optional)

- Pollen filter F5, activated carbon filter
- Filter unit for flat channel Corner, washable
- Wall mounting block D180 or Simplex R-D160
- Sound and wind protection accessories

External cover iV-Smart+ Corner
Reveal grille



White: RAL9016
Grey: RAL9006
Anthracite: RAL7016
North: RAL7011

Inner cover
iV-Smart+ Corner:
Flair (RAL9010)



Technical Specifications

| | | | |
|--|--------------|--|--------|
| Heat recovery [%] | 87 | Minimum wall thickness [mm] | 340 |
| Air volume flow per unit [m ³ /h] | 8.5 - 29 | Diameter of wall opening [mm] | 180 |
| Exhaust air volume flow per unit [m ³ /h] | 17 - 58 | Diameter of wall mounting sleeve [mm] | 160 |
| Sound pressure level [dB (A)], distance 1 m | 21 - 36 | Power consumption [W] | 3 |
| Standard sound level difference $D_{n,e,w}$ [dB] | 53 - 59 | Volume flow rel. power consumption [W/(m ³ /h)] | 0.15 |
| Dimensions inner cover Flair [W x H, mm] | 233 x 233 | Protection class | IP20 |
| Dimensions of reveal grille [W x H, mm] | 70 x 512 | Input voltage [V DC]: | 6 - 16 |
| Minimum wall thickness / Insulation [mm] | > 270 / > 70 | Energy efficiency class | A+ / A |

Installation diagram iV-Smart+ Corner

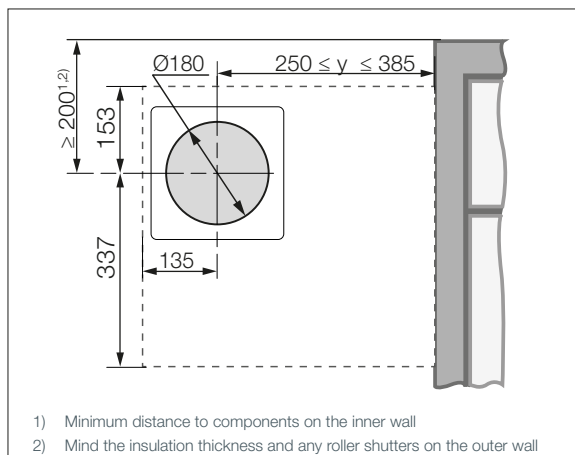
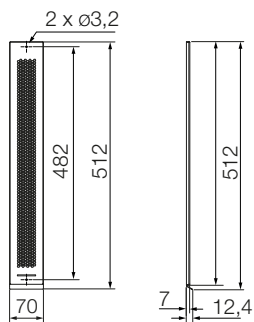
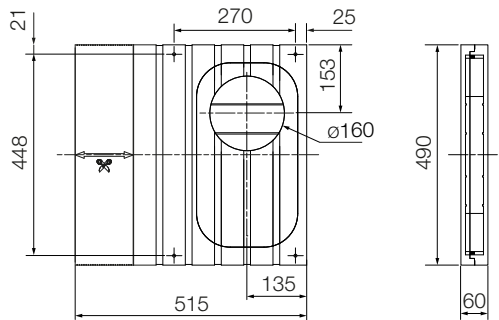
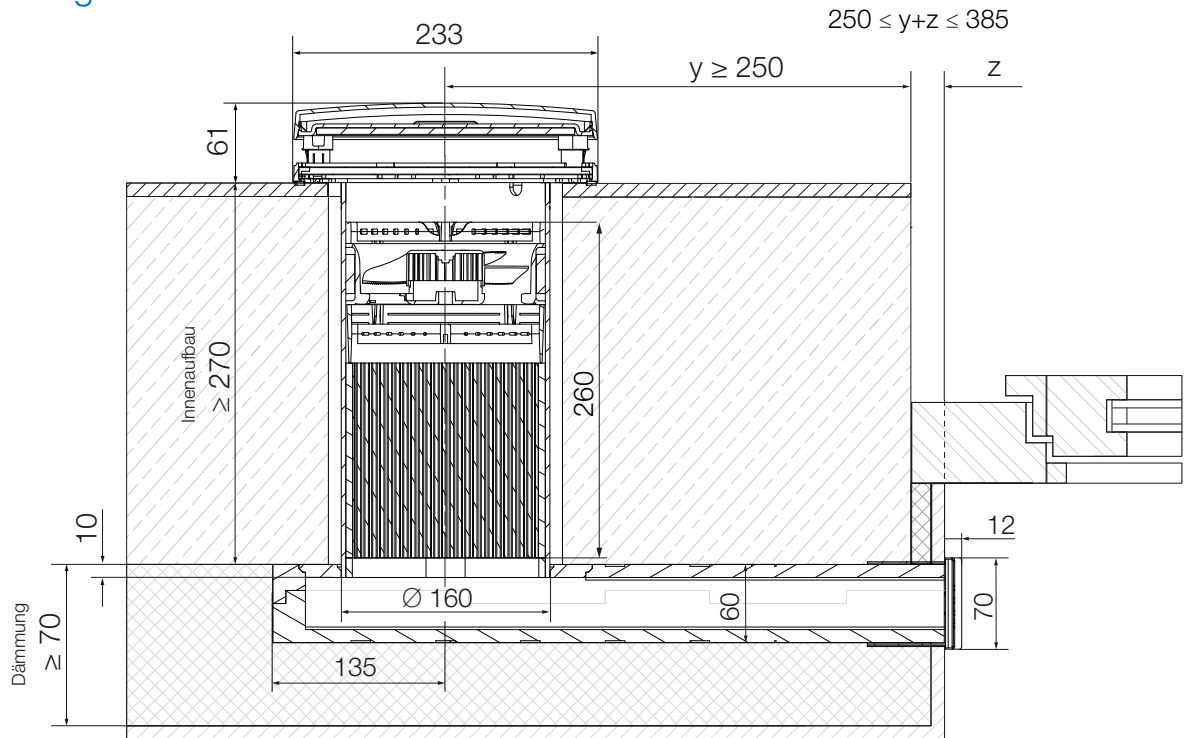

Remarks

When installing, observe the minimum distances in order to ensure that the system can be installed and functions properly. Minimum internal structure: 270 mm (masonry and interior construction/ plaster). The flat duct can be lined with insulating material (e.g. inVENTer UBP Corner substructure boards).

Minimum distances from centre axis core bore

- Insulation thickness on flat duct: > 10 mm
- to reveal (outside): 250 – 385 mm
- to components on the outer wall/ lintel: 155mm
Mind insulation thickness and possible roller shutters
- between two ventilation units in the same room: 1.2 m
- to other ventilation systems in the external area: 1.2 m

• Installation length of the flat duct:

$$L = (y + z) + 135, \text{ whereby } 250 \leq (y+z) \leq 385$$



DXF / DWG / STP

inVENTer iV-Smart+ Sylt



Decentralised ventilation system with heat recovery.
5-year manufacturer's warranty. For use in rooms below the earth's surface, basement, low ground floor.
Complete system for easy integration into the exterior wall.
External control via controller.

Minimal operating costs thanks to low power consumption of 3 W and the possibility of user maintenance.

Material for fitting to the façade or building base included.

Components

- Insert with ceramic honeycomb heat accumulator
- inVENTron®: Xenion® reversing fan with temperature monitor and wind pressure stabilizer, embedded in double air fin for flow rectification. Fan meets S3 classification according to DIN EN 13141-8.
- Internal screen with filter G4, wall mounting sleeve, riser pipe with condensate drain, hood pipe with hood cover

Controller

- MZ-Home, sMove s4/s8, controller system inVENTer Connect

Accessories (optional)

- Pollen filter F5, activated carbon filter
- Wall installation block D180

Technical Specifications

| | | | |
|--|-----------|--|--------|
| Heat recovery [%] | 87 | Minimum wall thickness [mm] | 270 |
| Air volume flow per unit [m ³ /h] | 8.5 - 29 | Diameter of wall opening [mm] | 180 |
| Exhaust air volume flow per unit [m ³ /h] | 17 - 58 | Diameter of wall mounting sleeve [mm] | 160 |
| Sound pressure level [dB (A)], distance 1 m | 21 - 36 | Power consumption [W] | 3 |
| Standard sound level difference $D_{n,e,w}$ [dB] | -- | Volume flow rel. power consumption [W/(m ³ /h)] | 0.15 |
| Dimensions inner cover Flair [W x H, mm] | 233 x 233 | Protection class | IP20 |
| Dimensions of top hood [Ø x H, mm] | 159 x 880 | Input voltage [V DC]: | 6 - 16 |
| | | Energy efficiency class | A+ / A |

Inner cover iV-Smart+ Sylt:
Flair (RAL9010)



External cover iV-Smart+ Sylt
Weather protection hood Sylt



| | | | |
|-------------------|-------------------|------------------|-----------------------|
| White: RAL9016 | Beige: RAL1001 | Grey: RAL9006 | Dark grey: RAL7015 |
|-------------------|-------------------|------------------|-----------------------|

Remarks

When installing, observe the minimum distances in the illustration on the right to ensure that the system can be installed.

Minimum wall thickness: 270 mm.

Pay attention to backwater levels and drainage possibility

The slat openings of the top hood protrude above the usual local snow depths.

All assembly and operating instructions as well as further information can be found at www.inventer.de.

Diagram wall opening iV-Smart+ Sylt

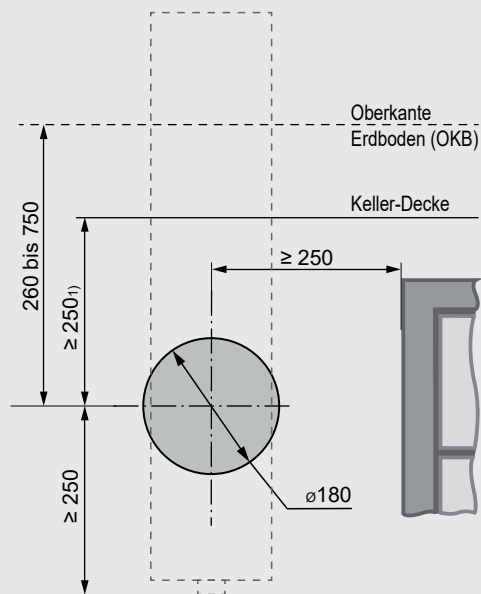

1) Minimum distance to components on the inner wall

Sectional drawing side view iV-Smart+ Sylt

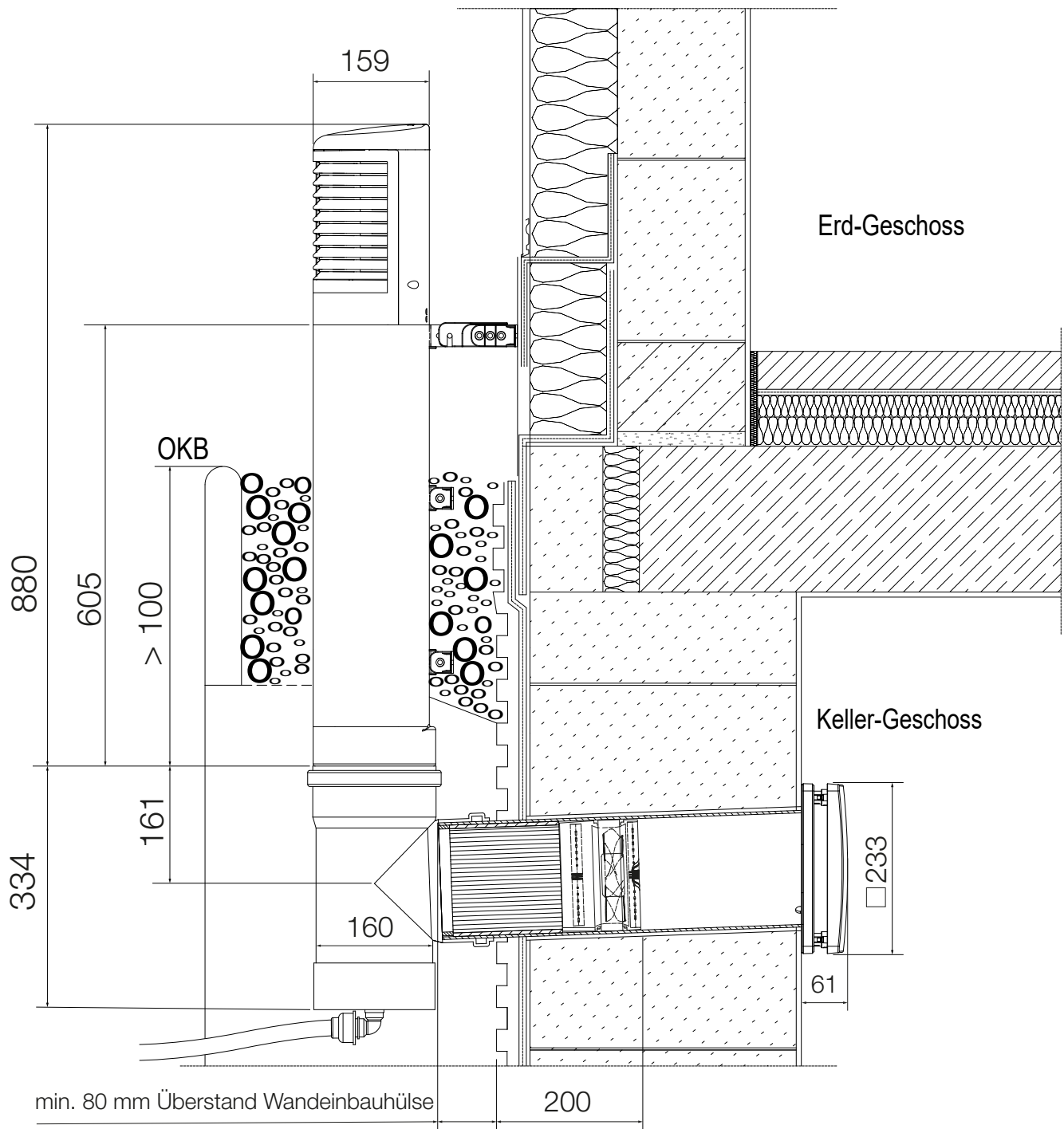

For your planning of the inVENTer ventilation systems, you can download DXF and DWG drawings of the ventilation units free of charge from our homepage www.inventer.de on the respective product pages.



inVENTer iV-Smart+ Top

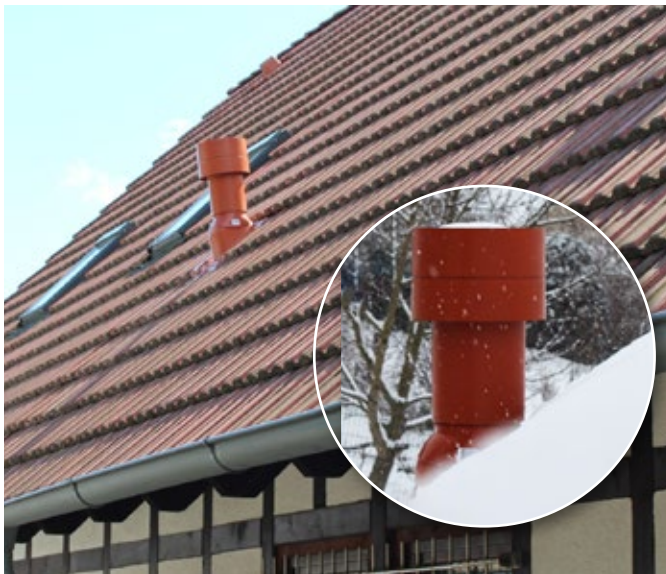

Decentralised ventilation system with heat recovery. 5-year manufacturer's warranty. For attic flats as installation in sloping roofs. Complete system for easy integration by means of a roof duct.

External control via controller.

Minimal operating costs thanks to low power consumption of 3 W and the possibility of user maintenance.

Roof passage in red / black for inclination angle 5 - 25 degrees or 25 - 45 degrees as optional accessory. Alternatively passage in the respective brick design on site.

Components

- Insert with ceramic honeycomb heat accumulator
- inVENTron®: Xenion® reversing fan with temperature monitor and wind pressure stabilizer, embedded in double air fin for flow rectification. Fan meets S3 classification according to DIN EN 13141-8.
- Internal panel with G4 filter, wall mounting sleeve with evaporating pantile and roof duct, weather protection hood with collar and rain-proof hood

Controller

- MZ-Home, sMove s4/s8, controller system inVENTer Connect

Accessories (optional)

- Pollen filter F5, activated carbon filter
- Soundproofing accessories

| Technical Specifications | | | |
|---|-----------|---|---------|
| Heat recovery [%] | 87 | Roof pitch angle | 5 – 45° |
| Air volume flow per unit [m³/h] | 8.5 - 29 | Diameter of wall opening [mm] | 180 |
| Exhaust air volume flow per unit [m³/h] | 17 - 58 | Diameter of wall mounting sleeve [mm] | 160 |
| Sound pressure level [dB (A)], distance 1 m | 21 - 36 | Power consumption [W] | 3 |
| Standard sound level difference $D_{n,e,w}$ [dB] | 41 - 45 | Volume flow rel. power consumption [W/(m³/h)] | 0.15 |
| Dimensions inner cover Flair [W x H, mm] | 233 x 233 | Protection class | IP20 |
| Dimensions of weather protection hood [Ø x H, mm] | 265 x 380 | Input voltage [V DC]: | 6 - 16 |
| | | Energy efficiency class | A+ / A |

Sectional drawing side view iV-Smart+ Top

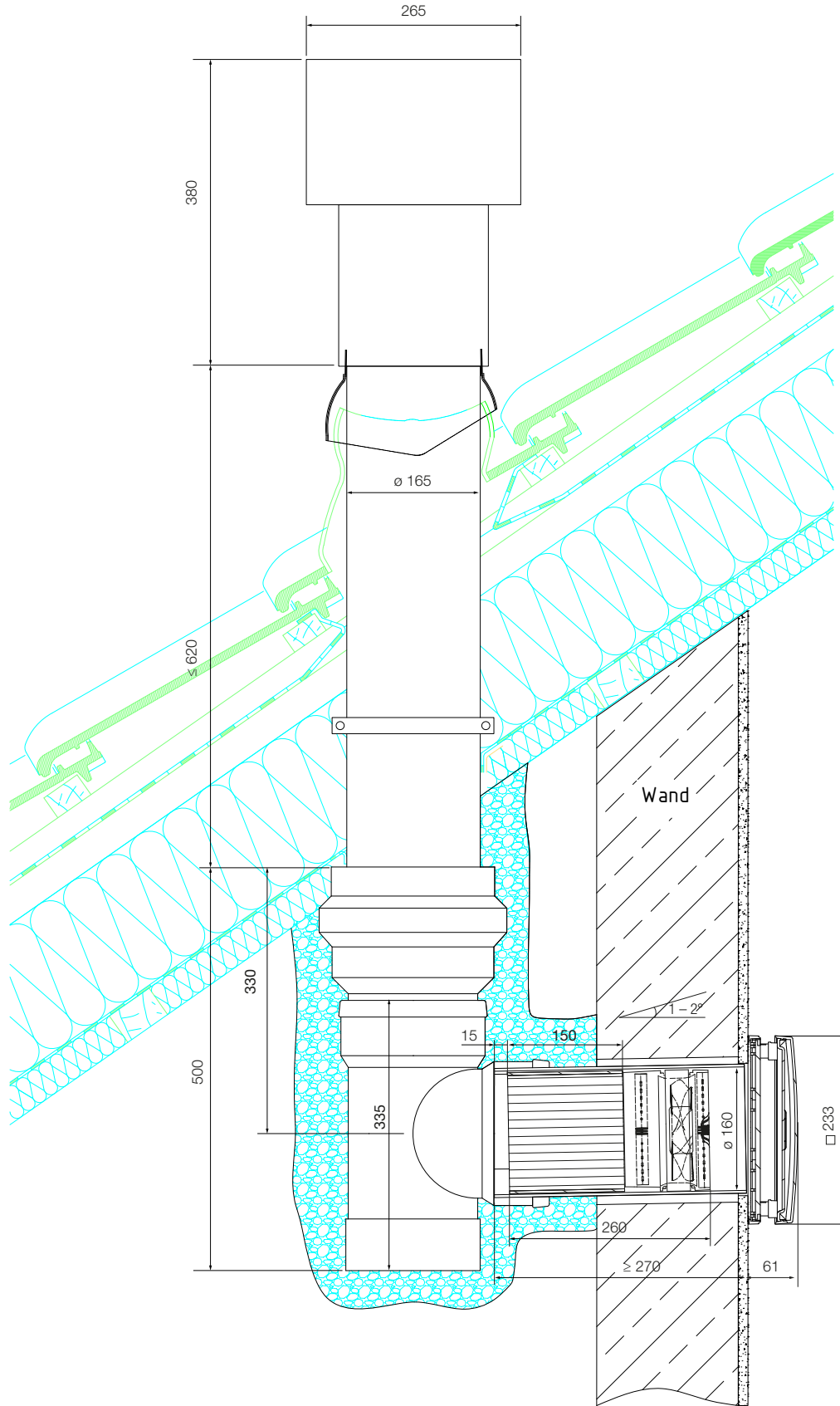

For your planning of the inVENTer ventilation systems, you can download DXF and DWG drawings of the ventilation units free of charge from our homepage www.inventer.de on the respective product pages.



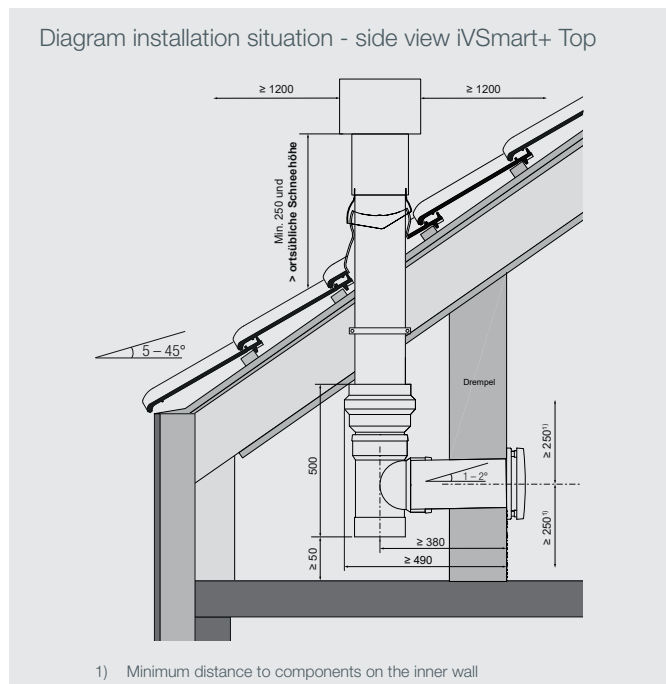
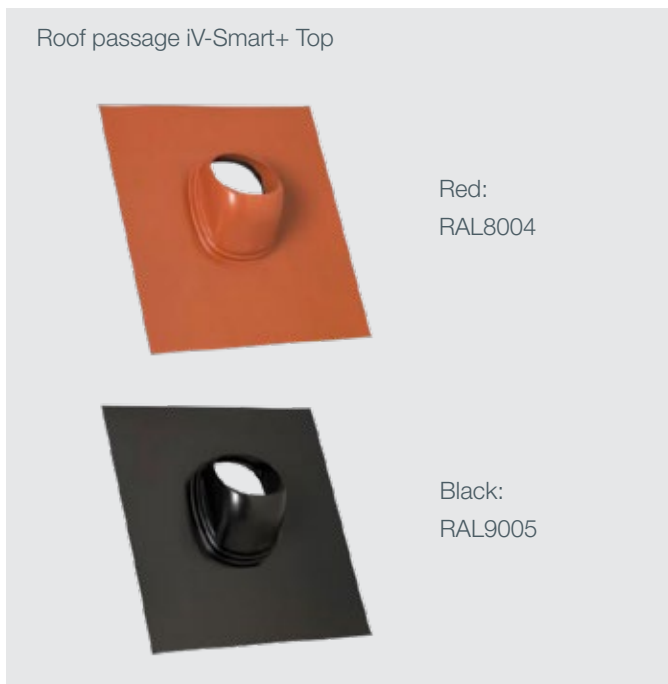

Remarks

When installing, observe the minimum distances in the illustration above to ensure that the system can be installed.
Insert through pan D160 or universal through passage on site.

The openings of the outer hoods must exceed the usual local snow heights.

Wall mounting sleeves located in unheated areas (e.g. behind the jam) must be insulated at the appropriate points.
Centre of wall opening in jamb and top hood vertical.

- Minimum distances from centre axis core bore
- to components on the inner wall/loib: 250 mm circumferential
 - to components on the outer wall: 250 mm circumferential
 - between two ventilation units in the same room: 1.2 m
 - to other ventilation systems in the external area: 1.2 m

All assembly and operating instructions as well as further information can be found at www.inventer.de

inVENTer iV14-Zero

iV14-Zero inside complete system

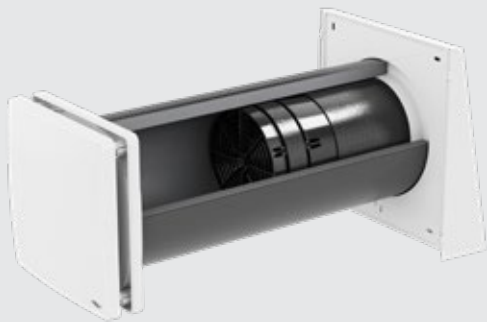

Decentralised ventilation system with heat recovery.

5-year manufacturer's warranty.

Sound insulation device for renovation and retrofitting. Complete system for easy integration into the exterior wall.

- Virtually noiseless thanks to innovative soundproofing concept (patent pending)
- Standard sound level diff. up to 56 dB due to Inventin® insert
- Level 1: Sound pressure level only 13 dB (A)
- Patented inVENTron® technology: 87 % Heat recovery

External control via controller. Quick installation with Simplex: Installation block with pre-installed wall installation sleeve, integrated slope.

Components

- Insert with ceramic honeycomb heat accumulator and Inventin® sound insulation insert
- inVENTron®: Xenion® reversing fan with temperature monitor and wind pressure stabilizer, embedded in double air fin for flow rectification. Fan meets S3 classification according to DIN EN 13141-8.
- Internal screen with filter G4, wall mounting sleeve, driving-rain proof weather protection hood

Controller

- MZ-Home, sMove s4/s8, controller system inVENTer Connect

Accessories (optional)

- Pollen filter F5, activated carbon filter
- Wall mounting block D230 or Simplex R-D200
- Sound and wind protection accessories

External cover iV14-Zero

Weather protection cover Flex

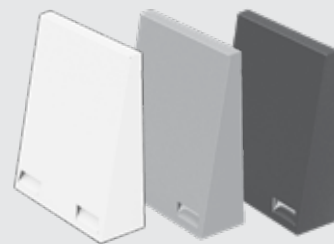

- White: RAL9016
- Grey: RAL9006
- North: RAL7011
- Anthracite: RAL7016

Inner cover iV14-Zero:
Flair Zero (RAL9010)



Technical Specifications

| | | | |
|---|-----------|---|--------|
| Heat recovery [%] | 87 | Minimum wall thickness [mm] | 255 |
| Air volume flow per unit [m³/h] | 8.5 - 29 | Diameter of wall opening [mm] | 225 |
| Exhaust air volume flow per unit [m³/h] | 17 - 58 | Diameter of wall mounting sleeve [mm] | 200 |
| Sound pressure level [dB (A)], distance 1 m | 13 - 29 | Power consumption [W] | 3 |
| Standard sound level difference $D_{n,e,w}$ [dB] | 48 - 56 | Volume flow rel. power consumption [W/(m³/h)] | 0.15 |
| Dimensions inner cover Flair [W x H, mm] | 233 x 233 | Protection class | IP20 |
| Dimensions of weather protection hood [W x H, mm] | 279 x 313 | Input voltage [V DC]: | 6 - 16 |
| | | Energy efficiency class | A+ / A |

Installation diagram iV14-Zero

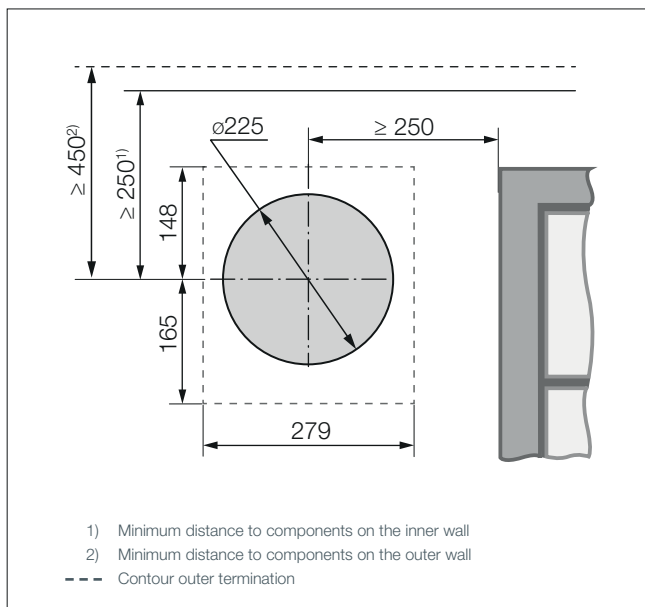
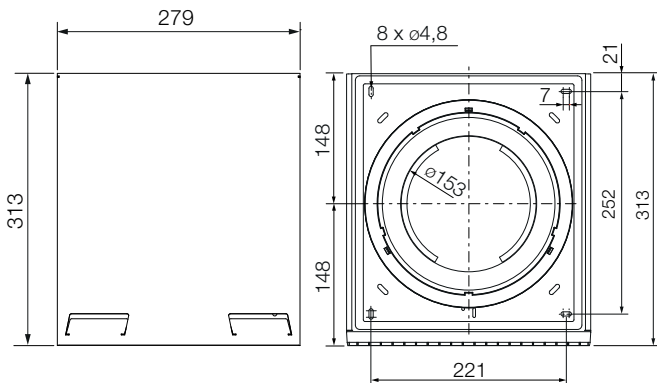
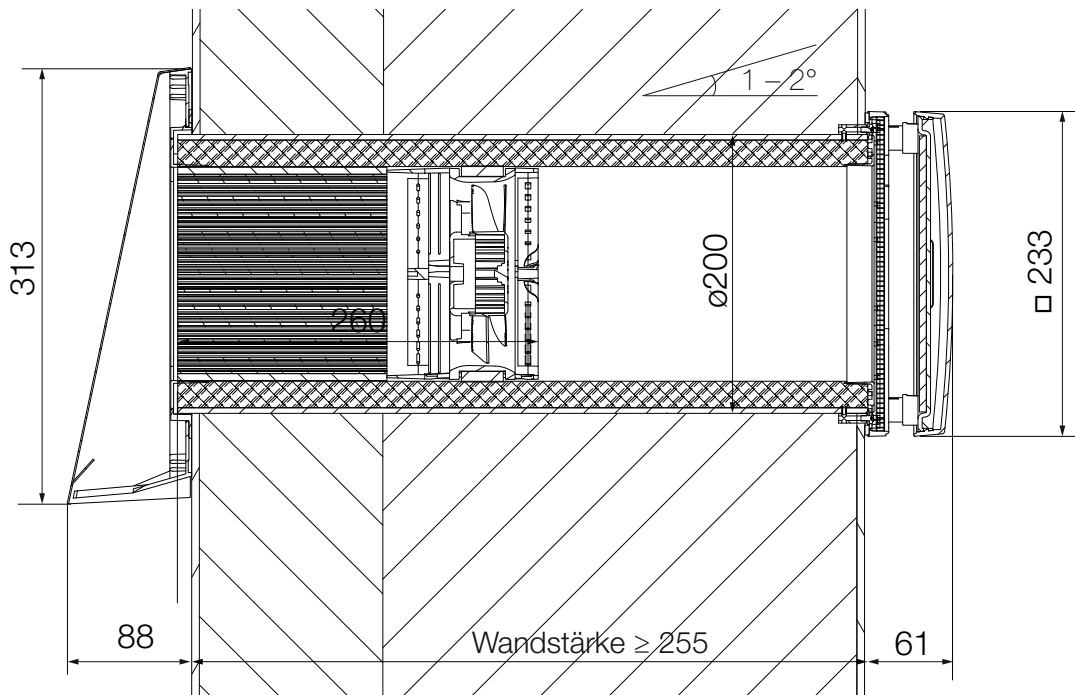

Remarks

To ensure that the system can be installed, observe the minimum clearances shown in the adjacent illustration.

Minimum wall thickness: 255 mm.

Minimum distances from centre axis core bore

- to components on the inner wall/loib: 250 mm circumferential
- to components on the outer wall 250 mm circumferential
Mind lintels, reveal edges, insulation thickness and possible
- between two ventilation units in the same room: 1.2 m.
- to other ventilation systems in the external area: 1.2 m.
- Recommendation: Mount the upper edge of the weather protection hood at the height of the lower edge of the lintel (optics on the façade).
- mount in the air volume flow of the room at approx. 1.80 m OKFFB optimally.

All assembly and operating instructions as well as further information can be found at www.inventer.de.



DXF / DWG / STP

inVENTer iV14-Zero Corner

iV14-Zero Corner inside complete system

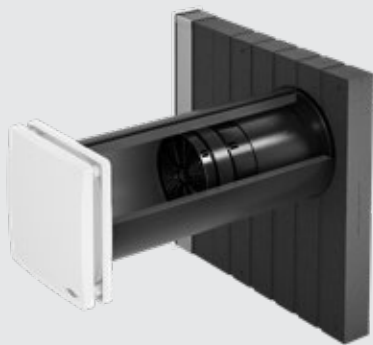

Decentralised ventilation system with heat recovery.

5-year manufacturer's warranty. Sound insulation device for renovation and subsequent installation with Corner duct as reveal variant.

Complete system for easy integration into the exterior wall.

- Virtually noiseless thanks to innovative soundproofing concept (patent pending)
- Standard sound level diff. up to 60 dB due to Inventin® insert
- Level 1: Sound pressure level only 13 dB (A)
- Patented inVENTron® technology: 87 % Heat recovery

External control via controller. Quick installation with Simplex: Installation block with pre-installed wall installation sleeve, integrated slope.

Components

- Insert with ceramic honeycomb heat accumulator and Inventin® sound insulation insert
- inVENTron®: Xenion® reversing fan with temperature monitor and wind pressure stabilizer, embedded in double air fin for flow rectification. Fan meets S3 classification according to DIN EN 13141-8.
- Internal panel with G4 filter, wall mounting sleeve, flat duct corner with integrated slope (incl. reveal grille)

Controller

- MZ-Home, sMove s4/s8, controller system inVENTer Connect

Accessories (optional)

- Filter unit for flat channel Corner, washable
- Pollen filter F5, activated carbon filter
- Wall mounting block D230 or Simplex R-D200
- Sound and wind protection accessories

External cover iV14-Zero Corner

Reveal grille



White: RAL9016
Grey: RAL9006
Anthracite: RAL7016
North: RAL7016

Inner cover iV14-Zero Corner:
Flair Zero (RAL9010)



Technical Specifications

| | | | |
|--|-----------|---|------------|
| Heat recovery [%] | 87 | Minimum wall thickness / Insulation [mm] | >270 / >70 |
| Air volume flow per unit [m³/h] | 8.5 - 29 | Diameter of wall opening [mm] | 225 |
| Exhaust air volume flow per unit [m³/h] | 17 - 58 | Diameter of wall mounting sleeve [mm] | 200 |
| Sound pressure level [dB (A)], distance 1 m | 13 - 29 | Power consumption [W] | 3 |
| Standard sound level difference $D_{n,e,w}$ [dB] | 55 - 60 | Volume flow rel. power consumption [W/(m³/h)] | 0.15 |
| Dimensions inner cover Flair [W x H, mm] | 233 x 233 | Protection class | IP20 |
| Dimensions of reveal grille [W x H, mm] | 70 x 512 | Input voltage [V DC]: | 6 - 16 |
| | | Energy efficiency class | A+ / A |

Installation diagram iV14-Zero Corner

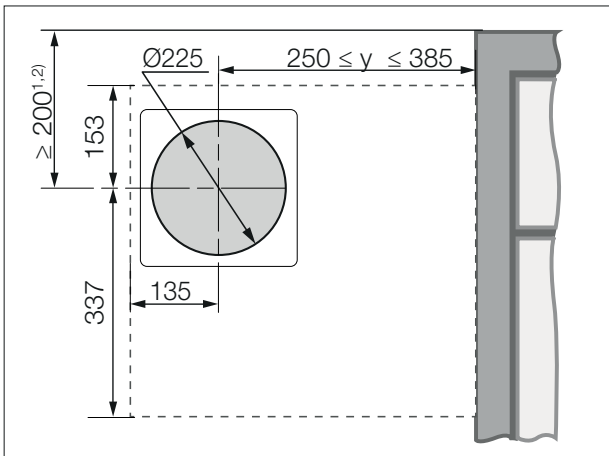
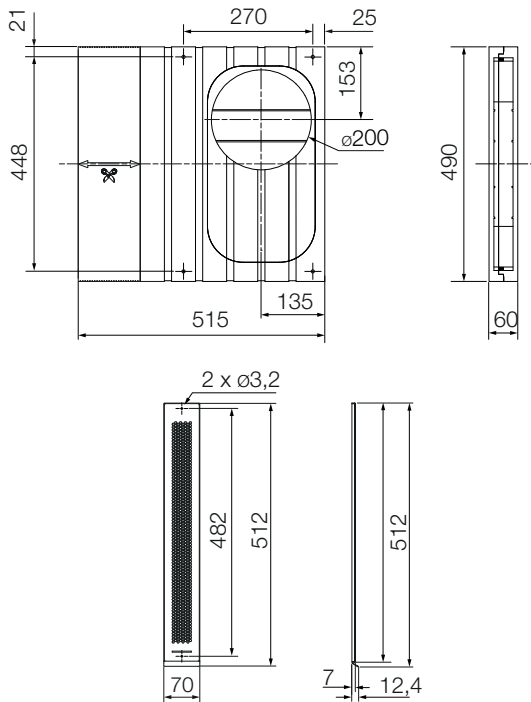
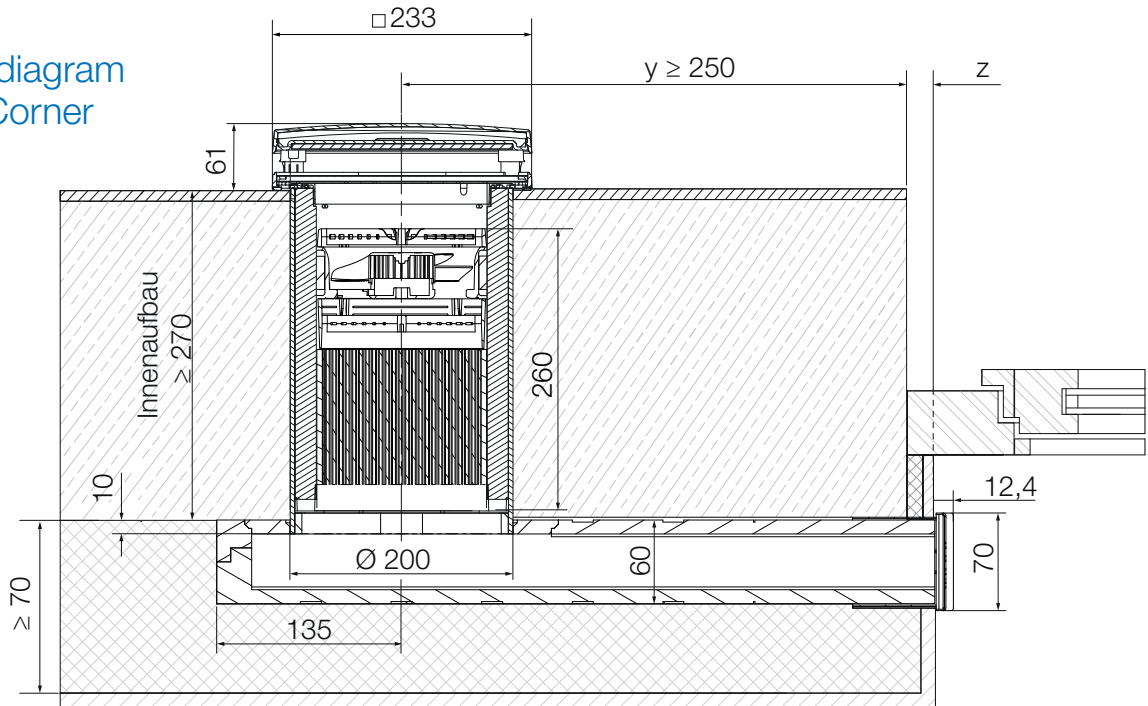

- 1) Minimum distance to components on the inner wall
- 2) Mind the insulation thickness and any roller shutters on the outer wall

Remarks

When installing, observe the minimum distances in order to ensure that the system can be installed and functions properly. Minimum internal structure: 270 mm (masonry and interior construction/ plaster). The flat duct can be lined with insulating material (e.g. inVENTer UBP Corner substructure boards).

Minimum distances from centre axis core bore

- Insulation thickness on flat duct: > 10 mm
 - to reveal (outside): 250 – 385 mm
 - to components on the outer wall/ lintel: 155mm
- Mind insulation thickness and possible roller shutters
- between two ventilation units in the same room: 1.2 m
 - to other ventilation systems in the external area: 1.2 m

Installation length of the flat duct:

$$L = (y + z) + 135, \text{ whereby } 250 \leq (y+z) \leq 385$$

All assembly and operating instructions as well as further information can be found at www.inventer.de.



DXF / DWG / STP

iV-Twin+ inside complete system



Decentralised ventilation system with 94% heat recovery. 5-year manufacturer's warranty. Single room unit for separate ventilation of individual rooms or supplementary system. Complete system for easy integration into the exterior wall. Does not require pairwise operation.

External control via controller. Control via separate controller with hygrostat or own ventilation zone is recommended.

Components

- 2 highly efficient ceramic heat accumulators in half cylinder design
- 2 reversing fans Mini-Xenion® in half cylinder design each with temperature monitor and wind pressure stabilizer, Incl. 2 Filter G3
- Wall mounting sleeve with vertical air volume flow separation
- Internal louvre with vertical air volume flow separation
- Driving rain proof weather protection hood with air volume flow separation wall mounting sleeve with vertical air volume flow separation

Controller

- MZ-Home, sMove s4/s8

Accessories (optional)

- Pollen filter F5, activated carbon filter
- Soundproofing accessories
- Wall mounting block D230 or Simplex R-D200

External cover iV-Twin+

Weather protection hood Flex Twin+

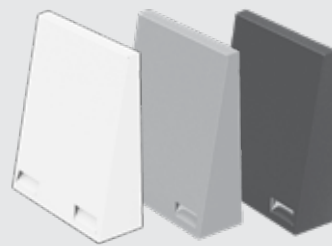

- White: RAL9016
- Grey: RAL9006
- North: RAL7011
- Anthracite: RAL7016

Inner cover iV-Twin+:

Flair Twin+ (RAL9010)



Technical Specifications

| | | | |
|---|-----------|---|--------|
| Heat recovery [%] | 94 | Minimum wall thickness [mm] | 270 |
| Air volume flow per unit [m³/h] | 5 - 23 | Diameter of wall opening [mm] | 225 |
| Exhaust air volume flow per unit [m³/h] | 10 - 45 | Diameter of wall mounting sleeve [mm] | 200 |
| Sound pressure level [dB (A)], distance 1 m | 20 - 44 | Power consumption [W] | 3 |
| Standard sound level difference $D_{n,e,w}$ [dB] | 45 - 56 | Volume flow rel. power consumption [W/(m³/h)] | 0.18 |
| Dimensions inner cover Flair [W x H, mm] | 233 x 233 | Protection class | IPX4 |
| Dimensions of weather protection hood [W x H, mm] | 279 x 313 | Input voltage [V DC]: | 6 - 16 |
| | | Energy efficiency class | A+ / A |

Installation diagram iV-Twin+

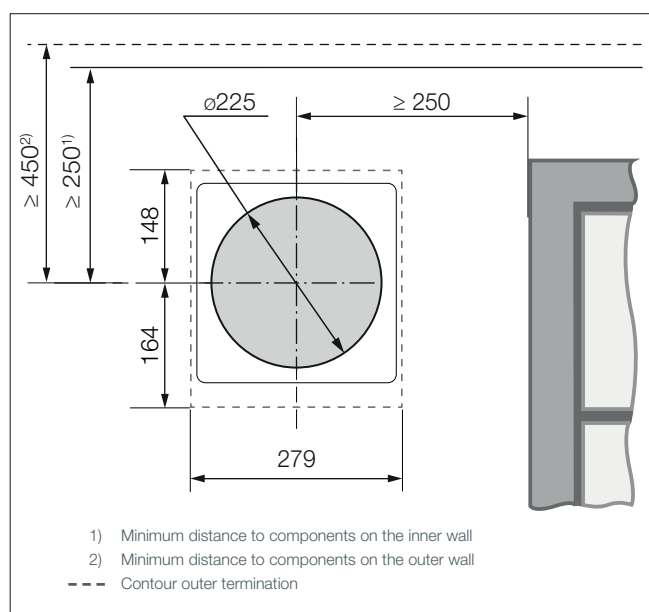
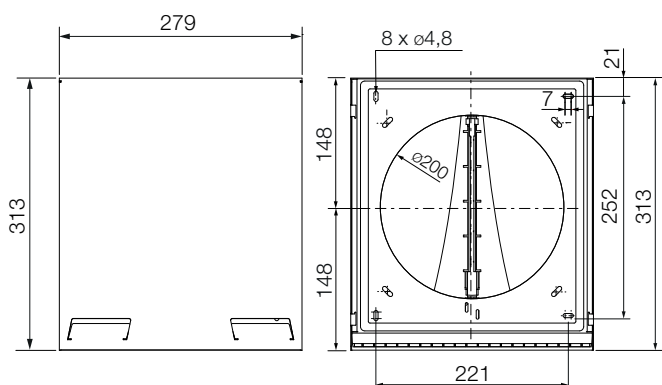
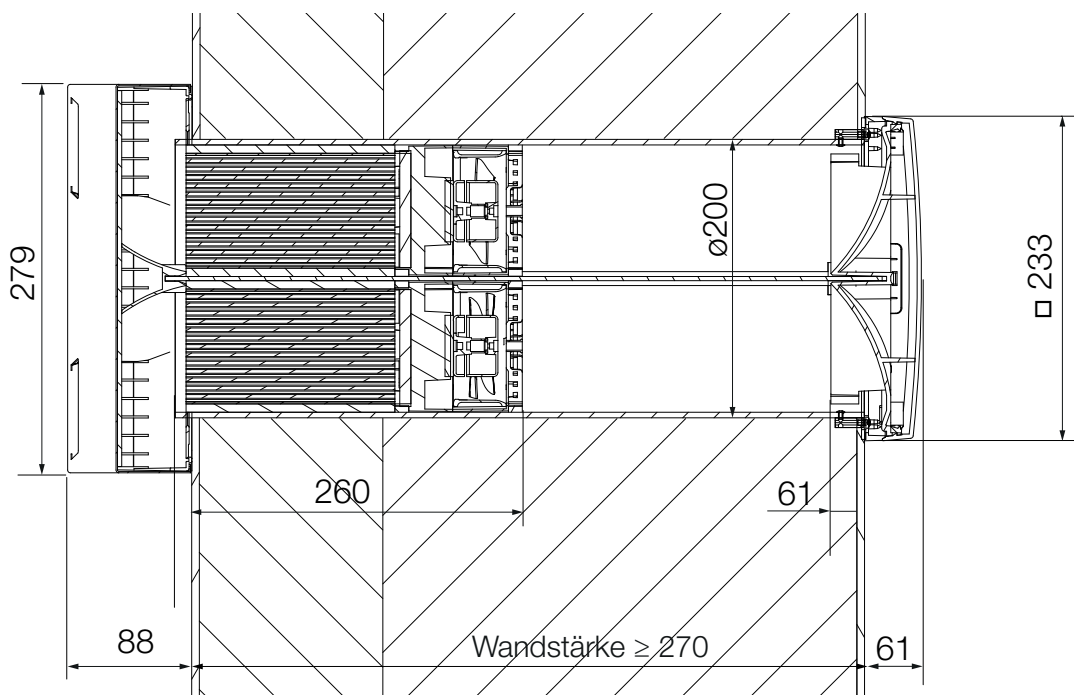

Remarks

To ensure that the system can be installed, observe the minimum clearances shown in the adjacent illustration.

Minimum wall thickness: 270 mm.

Minimum distances from centre axis core bore

- to components on the inner wall/loib: 250 mm circumferential
- to components on the outer wall 250 mm circumferential
Mind lintels, reveal edges, insulation thickness and possible roller shutters.
- between two ventilation units in the same room: 1.2 m
- to other ventilation systems in the external area: 1.2 m
- Recommendation: Mount the upper edge of the weather protection hood at the height of the lower edge of the lintel (optics on the façade).
- mount in the air volume flow of the room at approx. 1.80 m OKFFB optimally.

All assembly and operating instructions as well as further information can be found at www.inventer.de.



DXF / DWG / STP

inVENTer iV-Light

iV-Light inside complete system

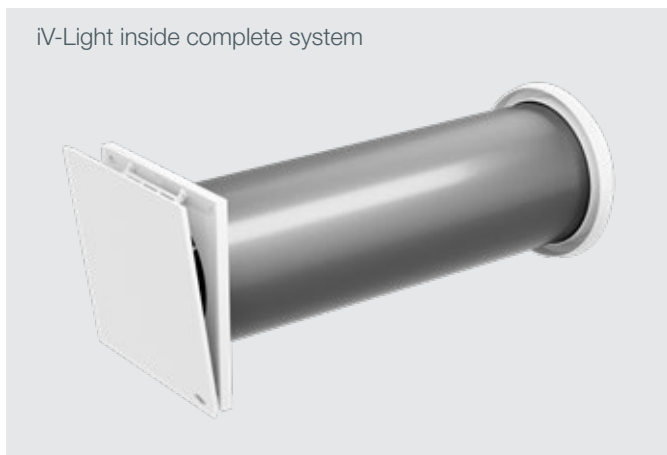

Decentralised ventilation system with heat recovery.
5-year manufacturer's warranty. Compact unit for new construction and renovation for easy integration in exterior walls.

External control via controller.

Quick installation with Simplex: Installation block with pre-installed wall installation sleeve, integrated slope.

Minimal operating costs thanks to low power consumption of 3 W and the possibility of user maintenance.

Components

- Insert with ceramic honeycomb heat regenerator
- inVENTron®: Xenion® reversing fan with temperature monitor and wind pressure stabilizer, embedded in double air fin for flow rectification, fans meet S3 classification according to DIN EN 13141-8, incl. G4 filter
- Wall mounting sleeve
- Internal panel
- Weather protection grille

Controller

- MZ-Home, sMove s4/s8, controller system inVENTer Connect

Accessories (optional)

- Pollen filter F5
- Sound and wind protection accessories
- Wall installation block D180 and Simplex R-D160

External cover iV-Light

Weather protection grille Light



White: RAL9016

Inner cover iV-Light



Technical Specifications

| | | | |
|--|-----------|--|--------|
| Heat recovery [%] | 84 | Minimum wall thickness [mm] | 290 |
| Air volume flow per unit [m ³ /h] | 5 - 21 | Diameter of wall opening [mm] | 180 |
| Exhaust air volume flow per unit [m ³ /h] | 10 - 42 | Diameter of wall mounting sleeve [mm] | 160 |
| Sound pressure level [dB (A)], distance 1 m | 18 - 36 | Power consumption [W] | 1 - 3 |
| Standard sound level difference $D_{n,e,w}$ [dB] | 34 - 47 | Volume flow rel. power consumption [W/(m ³ /h)] | 0.2 |
| Dimensions inner cover Light [W x H, mm] | 220 x 220 | Protection class | IP20 |
| Dimensions of weather protection hood [Ø, mm] | Ø 200 | Input voltage [V DC]: | 6 - 16 |
| | | Energy efficiency class | A+ / A |

Installation diagram iV-Light

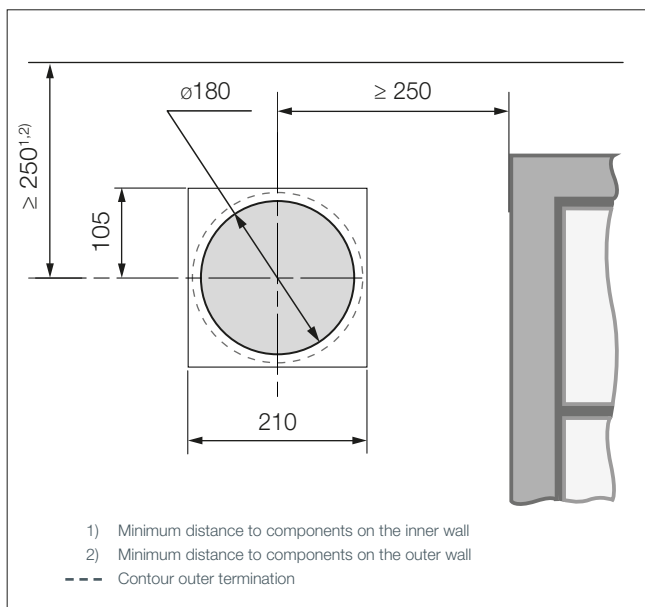
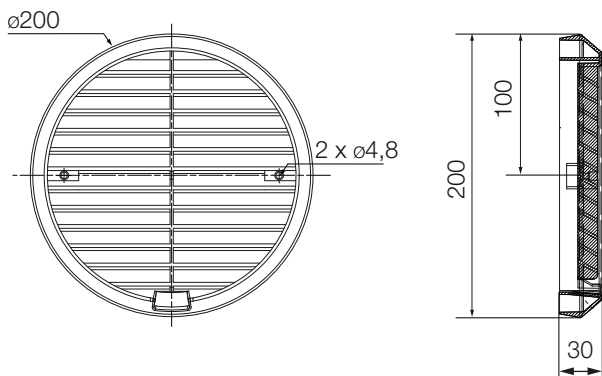
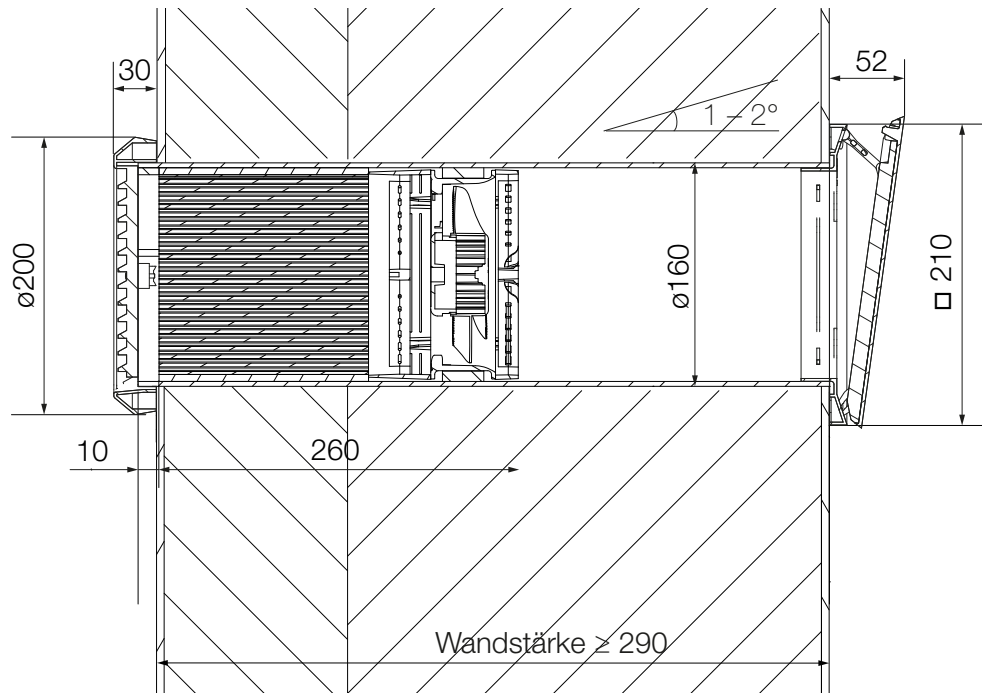

Remarks

To ensure that the system can be installed, observe the minimum clearances shown in the adjacent illustration.

Minimum wall thickness: 290 mm.

Minimum distances from centre axis core bore

- to components on the inner wall/loib: 250 mm circumferential
- to components on the outer wall 250 mm circumferential
Mind lintels, reveal edges, insulation thickness and possible roller shutters.
- between two ventilation units in the same room: 1.2 m
- to other ventilation systems in the external area: 1.2 m
- Recommendation: Mount the upper edge of the weather protection hood at the height of the lower edge of the lintel (optics on the façade).
- mount in the air volume flow of the room at approx. 1.80 m OKFFB optimally.

All assembly and operating instructions as well as further information can be found at www.inventer.de.



DXF / DWG / STP

inVENTer iV-Compact

iV-Compact inside complete system



Decentralised ventilation system with heat recovery. 5-year manufacturer's warranty.

Compact unit for new construction and renovation for easy integration in exterior walls with very thin walls (≥ 140 mm).

External control via controller.

Quick installation with Simplex: Installation block with pre-installed wall installation sleeve, integrated slope.

Minimal operating costs thanks to low power consumption of 3 W and the possibility of user maintenance.

Components

- Insert with ceramic honeycomb heat regenerator
- inVENTron®: Xenion® reversing fan with temperature monitor and wind pressure stabilizer, embedded in double air fin for flow rectification, fans meet S3 classification according to DIN EN 13141-8, incl. G4 filter
- Wall mounting sleeve
- Internal panel
- Driving rain proof weather protection hood

Controller

- MZ-Home, sMove s4/s8, controller system inVENTer Connect

Accessories (optional)

- Pollen filter F5
- Sound and wind protection accessories

External cover iV-Compact

Weather protection hood Compact



White: RAL9016
Grey: RAL9006

Inner cover iV-Compact:
Flair (RAL9010)



Technical Specifications

| | | | |
|--|-----------|--|--------|
| Heat recovery [%] | 72 | Minimum wall thickness [mm] | 140 |
| Air volume flow per unit [m ³ /h] | 10.5 – 29 | Diameter of wall opening [mm] | 180 |
| Exhaust air volume flow per unit [m ³ /h] | 21 - 58 | Diameter of wall mounting sleeve [mm] | 160 |
| Sound pressure level [dB (A)], distance 1 m | 21 - 44 | Power consumption [W] | 3 |
| Standard sound level difference $D_{n,e,w}$ [dB] | 32 | Volume flow rel. power consumption [W/(m ³ /h)] | 0.13 |
| Dimensions inner cover Flair [W x H, mm] | 233 x 233 | Protection class | IP20 |
| Dimensions of weather protection hood [W x H, mm] | 203 x 276 | Input voltage [V DC]: | 6 - 16 |
| | | Energy efficiency class | A |

Installation diagram iV-Compact

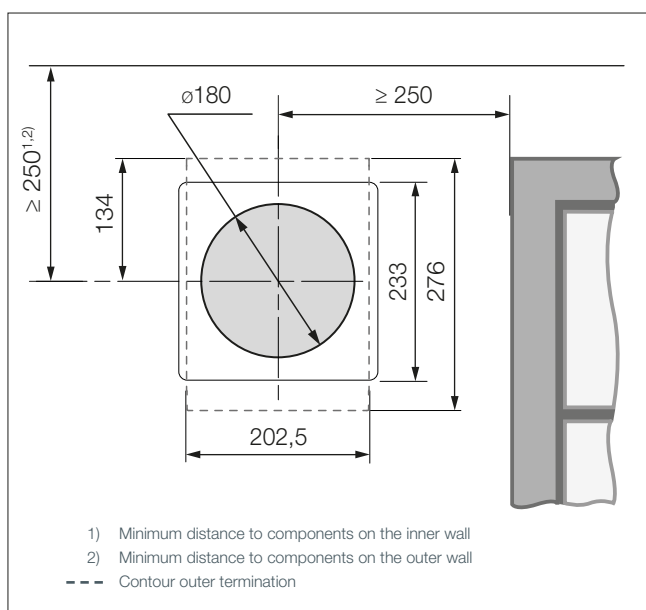
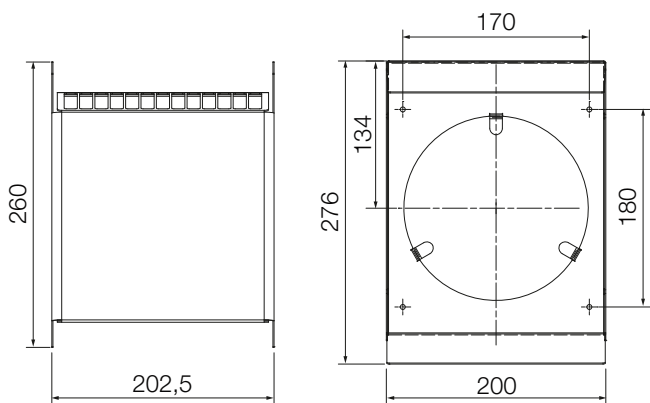
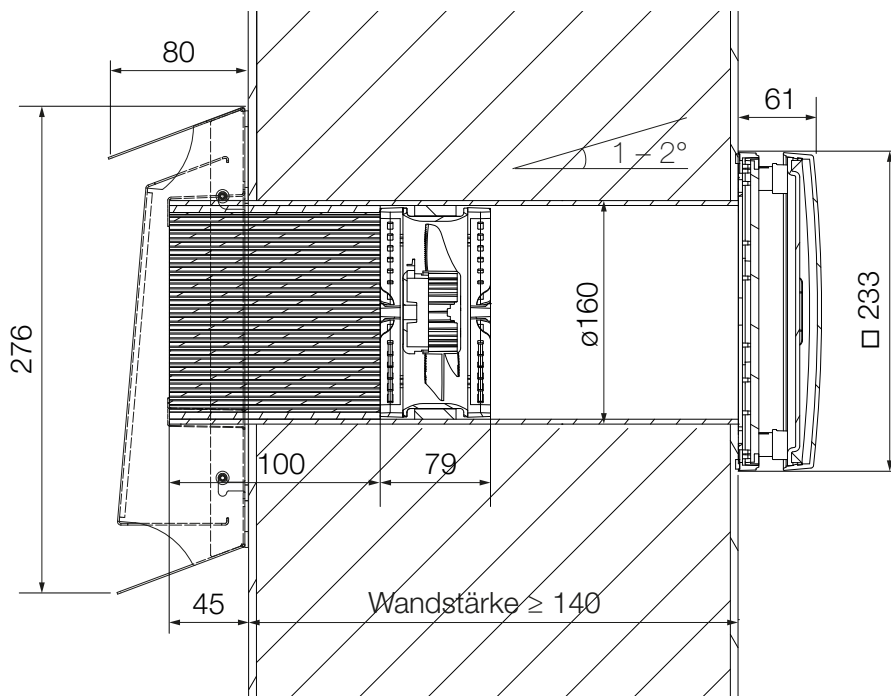

Remarks

To ensure that the system can be installed, observe the minimum clearances shown in the adjacent illustration.
Minimum wall thickness: 140 mm.

Minimum distances from centre axis core bore

- to components on the inner wall/loib: 250 mm circumferential
- to components on the outer wall 250 mm circumferential
Mind lintels, reveal edges, insulation thickness and possible roller shutters.
- between two ventilation units in the same room: 1.2 m
- to other ventilation systems in the external area: 1.2 m
- Recommendation: Mount the upper edge of the weather protection hood at the height of the lower edge of the lintel (optics on the façade).
- mount in the air volume flow of the room at approx. 1.80 m OKFFB optimally.

All assembly and operating instructions as well as further information can be found at www.inventer.de.



DXF / DWG / STP

inVENTer iV25

iV25 exploded view of complete system



- Highly efficient ceramic heat accumulator
- Reversing fan
- Wall mounting sleeve
- Internal panel
- Filter G3
- Driving rain proof weather protection hood

Controller

- MZ-Home, sMove s4/s8

Accessories (optional)

- Pollen filter F5, activated carbon filter
- Soundproofing accessories

Decentralised ventilation system with heat recovery.
5-year manufacturer's warranty.

Powerful unit for increased air volume flow requirements.

Complete system for easy integration into the exterior wall.

Components

External cover iV25

Weather protection cover Flex

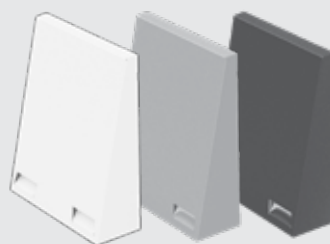

White: RAL9016

Grey: RAL9006

North: RAL7011

Anthracite: RAL7016

Inner cover iV25:
Classic (RAL9010)



Technical Specifications

| | | | |
|--|---------------|--|------------|
| Heat recovery [%] | Ø 72, max. 77 | Minimum wall thickness [mm] | 270 |
| Air volume flow per unit [m ³ /h] | 23.5 - 55 | Diameter of wall opening [mm] | 270 |
| Exhaust air volume flow per unit [m ³ /h] | 47 - 110 | Diameter of wall mounting sleeve [mm] | 250 |
| Sound pressure level [dB (A)], distance 1 m | 29 - 47 | Power consumption [W] | 2 - 5 |
| Standard sound level difference $D_{n,e,w}$ [dB] | 35 - 44 | Volume flow rel. power consumption [W/(m ³ /h)] | up to 0.16 |
| Dimensions of inner cover Classic [Ø, mm] | 290 | Protection class | IP20 |
| Dimensions of weather protection hood [W x H, mm] | 279 x 313 | Input voltage [V DC]: | 6 - 16 |
| | | Energy efficiency class | A / B |

Installation diagram iV25 with weather protection hood Flex

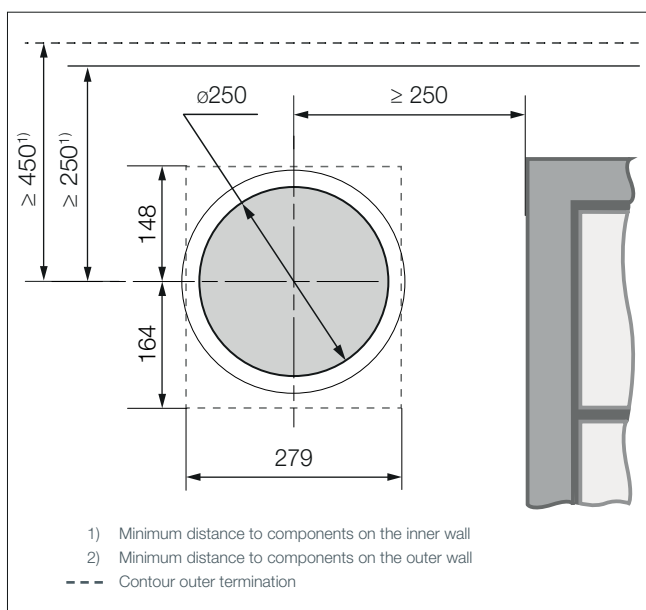
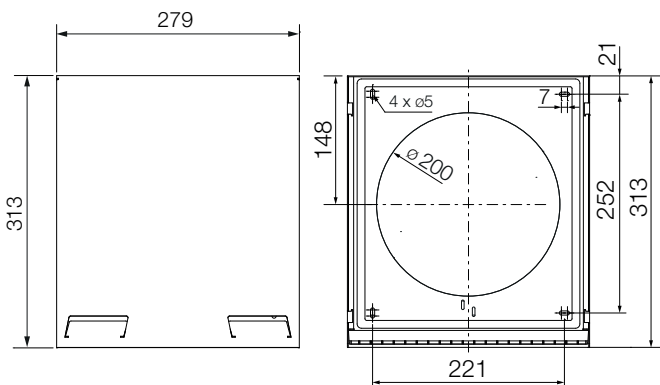
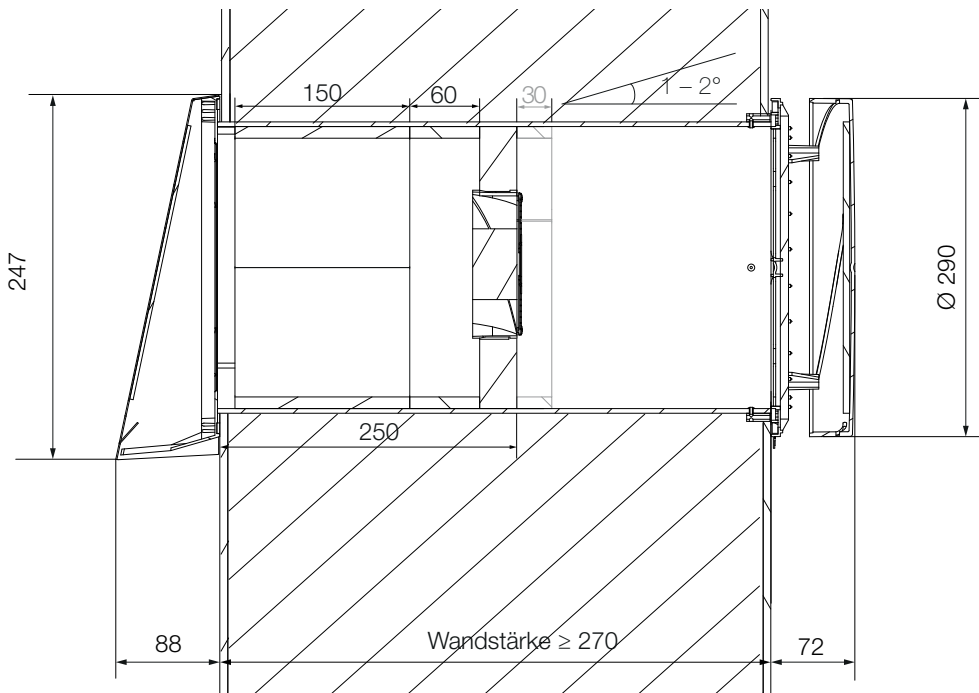

Remarks

To ensure that the system can be installed, observe the minimum clearances shown in the adjacent illustration.
 Minimum wall thickness: 270 mm.

Minimum distances from centre axis core bore

- to components on the inner wall/loib: 250 mm circumferential
- to components on the outer wall 250 mm circumferential
 Mind lintels, reveal edges, insulation thickness and possible roller shutters.
- between two ventilation units in the same room: 1.2 m
- to other ventilation systems in the external area: 1.2 m
- Recommendation: Mount the upper edge of the weather protection hood at the height of the lower edge of the lintel (optics on the façade).
- mount in the air volume flow of the room at approx. 1.80 m OKFFB optimally.

All assembly and operating instructions as well as further information can be found at www.inventer.de.



DXF / DWG / STP

inVENTer PAX

inVENTer PAX Interior view complete system



Application example PAX in a hotel room (top view)

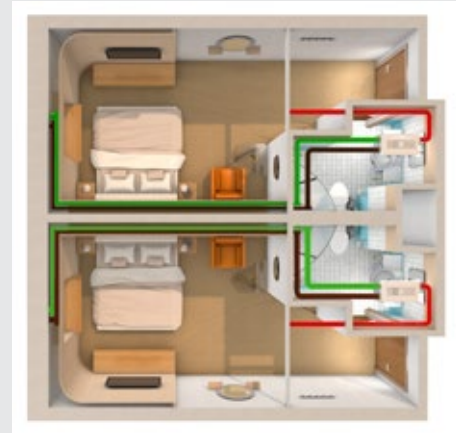

Ventilation system for increased sound insulation ventilation with heat recovery and automatic humidity monitoring. 5-year manufacturer's warranty. Suitable for new construction and renovation.

Installation in exhaust air rooms with moisture ingress. Connection directly to external wall or optionally via piping for ventilation of internal rooms with heat recovery. Can be installed in false ceilings. Complete unit for ventilation of micro apartments.

Integrated preheating coil and cross-flow heat exchanger. Operation directly on the unit or via remote control.

Auto-calibration of the air volume flow during initial commissioning.

Operating modes Normal, Buzzer, Eco and Comfort.

Components Basic Set

- Main module incl. radial fan, filter system G4, heating coil, cross-flow heat exchanger and control unit
- Insulated wall duct, flat weather protection hood
- Infrared remote control
- Silencer
- Connector

Accessories (optional)

- Spiral duct, L 995 mm
- Poppet valve supply air
- Silencer
- Connector Nipple & Sleeve
- Elbow 90° incl. lip seal
- T-piece incl. lip seal
- End cap tube
- Pipe system
- Fastening clip
- Dust filter set

Technical Specifications

| | | | |
|--|--------------------|--|-------------------|
| Heat recovery [%] | Ø 77, max. 80 | Dimensions of weather protection hood [W x H x D, mm] | |
| Air volume flow [m³/h] | 30 - 78 | Horizontally | 393 x 212 x 52 |
| Exhaust air volume flow [m³/h] | 90 | Vertically | 203 x 389 x 66 |
| Sound pressure level heat recovery [dB (A)] | 19 - 29 | Diameter of wall opening [mm] | 2 x 160 |
| Sound pressure level exhaust air [dB (A)] | 35 | Power consumption [W] | 3.5 - 25 |
| Standard sound level difference exhaust air space [dB] | 47 | Electric preheating coil [W] | max. 375 |
| Standard sound level difference fresh air space [dB] | 77 | Protection class | II |
| Dimensions of main module [W x H x D, mm] | 720 x 340 x 191 | Protection type | IP24 |
| | | Mains voltage [V AC], [Hz] | 230, 50 |
| | | Energy efficiency class | A |

Remarks

- Minimum clearance between two outer hoods and other ventilation components in the outside area: 1.2 m
- Minimum clearance to adjacent components: 250 mm
- Observe sound decoupling: Pipe systems and wall ducts must be designed with structure-borne sound insulation in mind (use a silencer downstream of the unit and between two rooms).
- Mount on a firm, level and permanently load-bearing surface.
- Connection with permanent wiring.
- Make sure that there is enough space to open the front panel, and ensure a visual view of the front panel.
- Connect each ventilation unit to its own outdoor and exhaust air connection.
- Maximum length of the pipe system: 10 m

inVENTer PAX Functionality

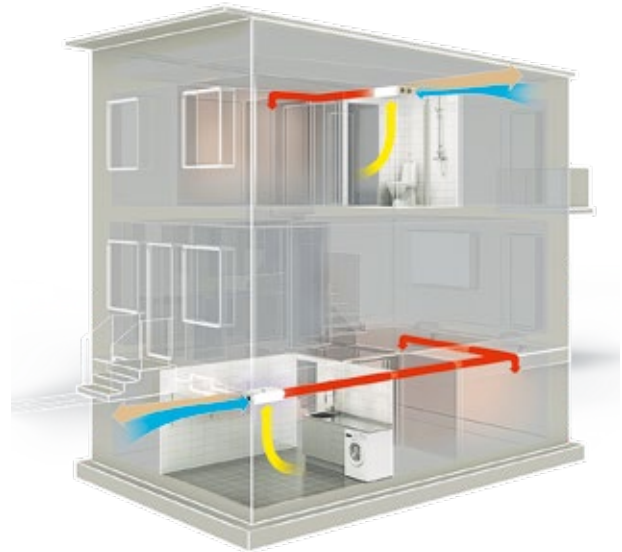

Installation with roof outlet

- Installation of the ventilation unit horizontally only.
- Minimum clearance to adjacent interior components: 85 mm
- The roof hood must surpass local snow heights and be rain-proof.
Minimum clearance between two outer hoods / to further air handling components in the exterior: 1.2 m
- Insulate external and exhaust air ducts from diffusion.
- Consider provisions for condensate drainage in external and exhaust air ducts.
- Wall mounting sleeves located in unheated areas must be insulated at the appropriate spaces.

Airflows at the PAX main module

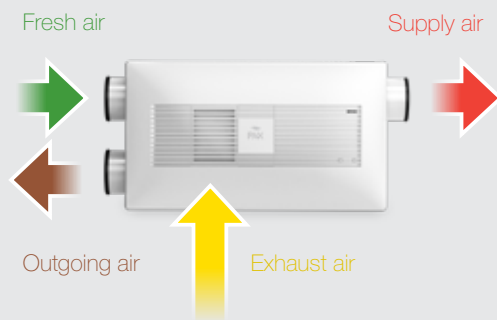

Schematic wall opening outside wall, horizontal installation

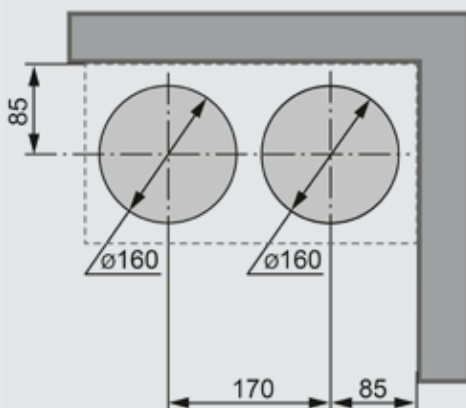

PAX weather protection hoods



Installation diagram inVENTer PAX

Schematic installation position: horizontal in false ceiling, side view

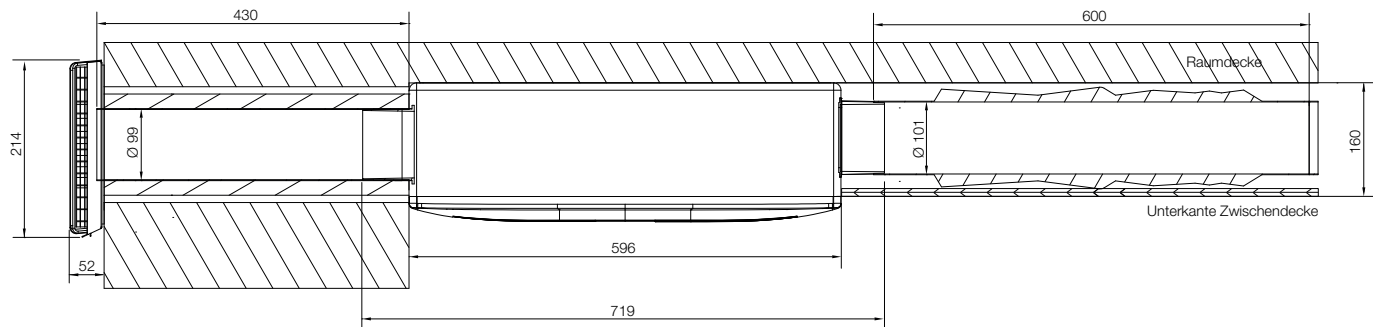

Schematic mounting position: Installation in ceiling, view from below

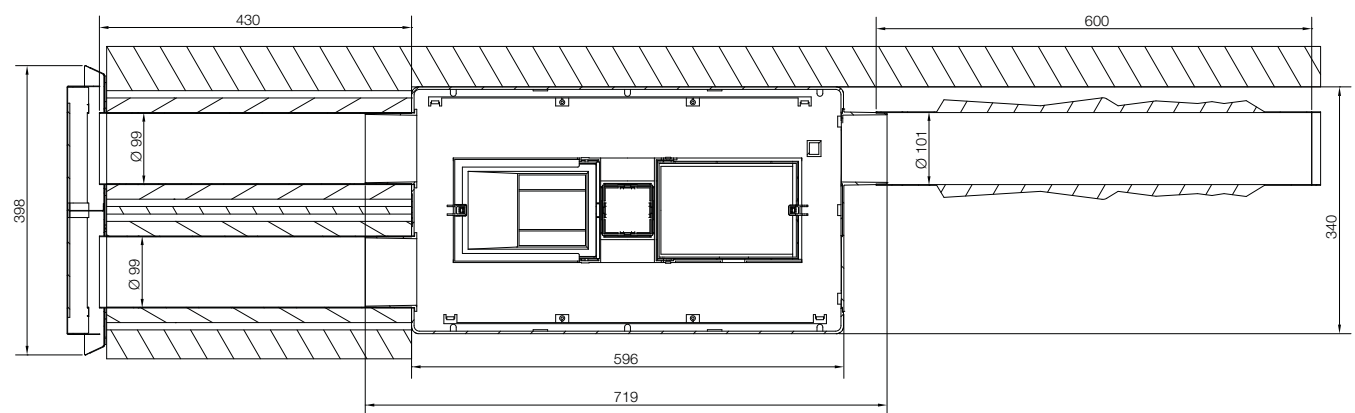

For your planning of the inVENTer ventilation systems, you can download DXF and DWG drawings as well as STP models of the ventilation units free of charge from our homepage www.inventer.de on the respective product pages.



Air volume flow-pressure curve

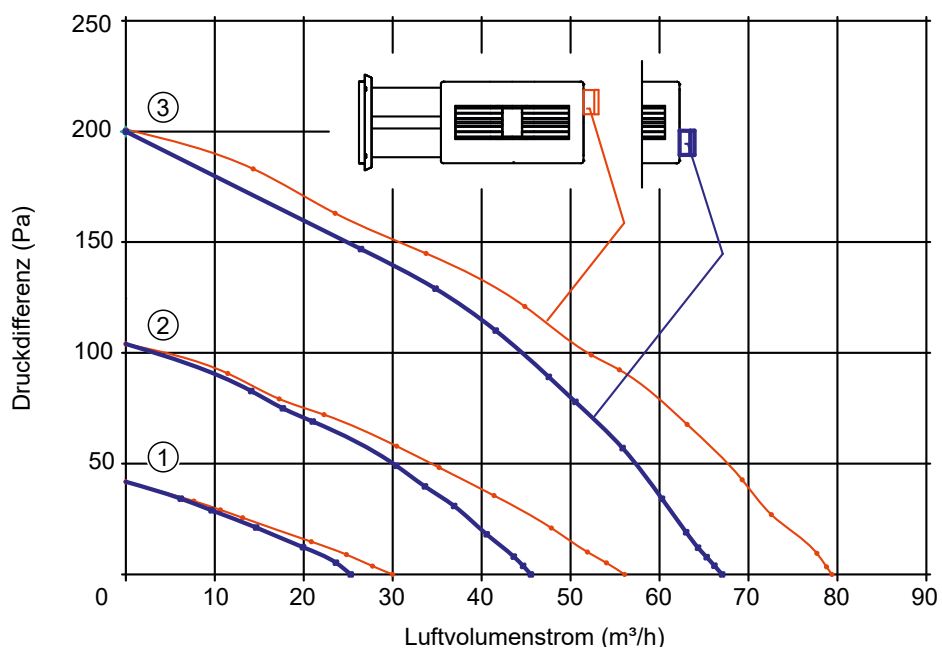



Overflow System USTS 100 Pulsar

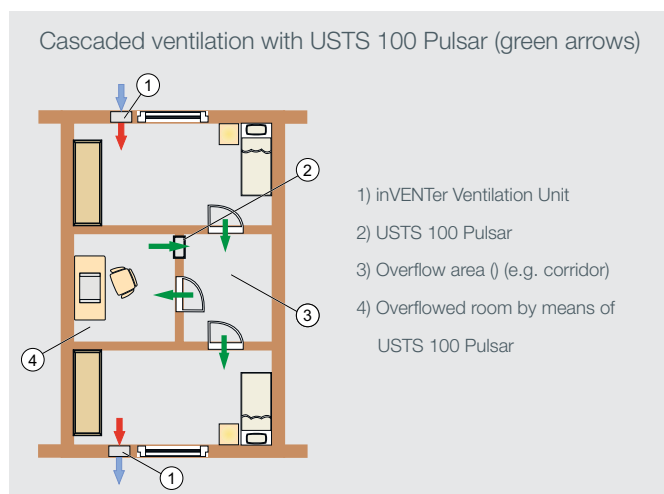
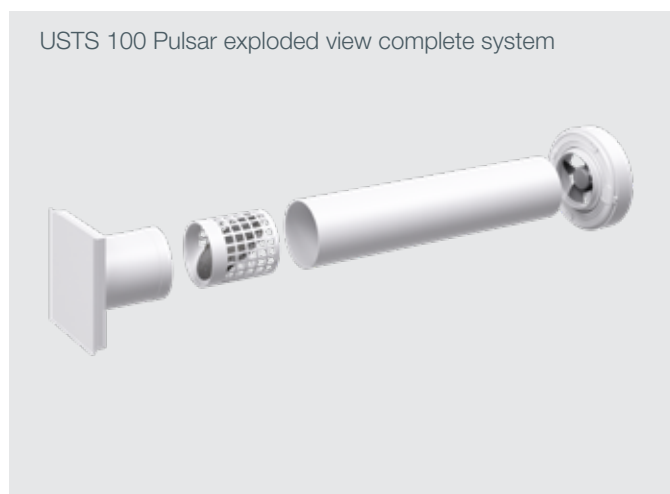

Ventilation system for active ventilation support from room to room for integration in interior walls.

Programming and control via Bluetooth using the "inVENTer Mobile" application. Not suitable for ventilation of interior sanitary rooms according to DIN 18017-3. Meets the mechanical safety requirements of 60335-8-20. Minimal operating costs thanks to low power consumption and the possibility of user maintenance. 5-year manufacturer's warranty.

The USTS 100 Pulsar operates without heat recovery. Cascade ventilation can be implemented in conjunction with the iV ventilation systems.

Components

- Multifunctional overflow fan
- Wall mounting sleeve
- Internal panel
- Filter cartridge with dust filter

Modes of operation

- Continuous ventilation
- Sensor-controlled (light sensor)
- Interval operation
- Overflow based on defined temperature limit value

| Overflow air volume flow rate $q_{v,ÜLD}$ [m³/h] | | 10 | 20 | 30 | 40 | 50 | 60 | 70 | 80 | 90 | 100 |
|--|------------------------------------|----|----|----|-----|-----|-----|-----|-----|-----|-----|
| Doors with grommets | Free minimum area $A_{ÜLD}$ in cm² | 25 | 50 | 75 | 100 | 125 | 150 | 175 | 200 | 225 | 250 |
| Laterally and top | | | | | | | | | | | |
| Doors without grommet | | 0 | 25 | 50 | 75 | 100 | 125 | 150 | 175 | 200 | 225 |

| Technical Specifications | |
|--------------------------------------|---------|
| Minimum wall thickness [mm] | 120 |
| Diameter of wall opening [mm] | 115 |
| Air volume flow [m³/h] | 30 |
| Power consumption [W] | 4 |
| Mains voltage [V AC], [Hz]: | 230, 50 |
| Alternative operating voltage [V DC] | 12 |
| Sound emission [dB (A)] | 17 - 20 |
| Protection type | 44 |
| Protection class | II |
| Dust filter class | G1 |

Download App
inVENTer Mobile:



You can find detailed information about the requirements for the operating system in the stores and on www.inventer.de

Installation diagram overflow system USTS Pulsar

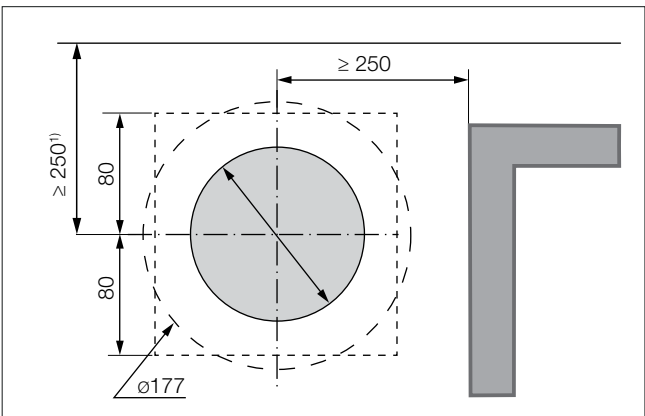
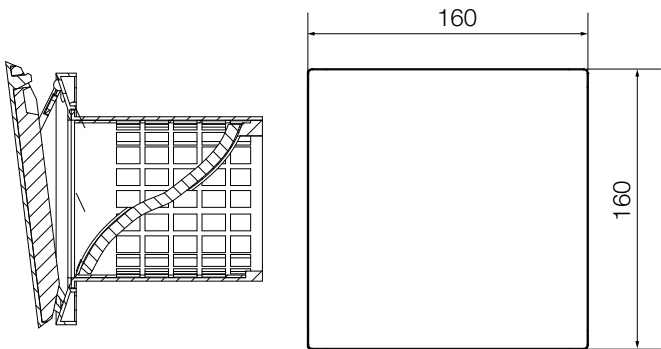
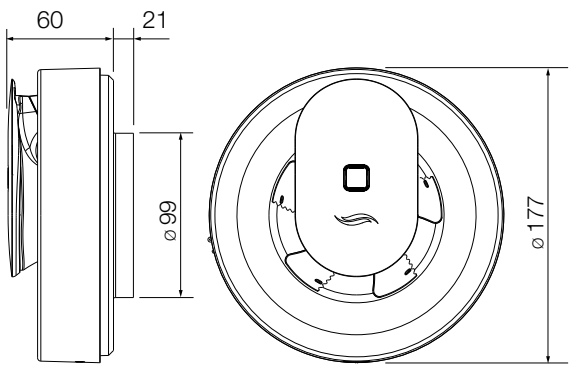
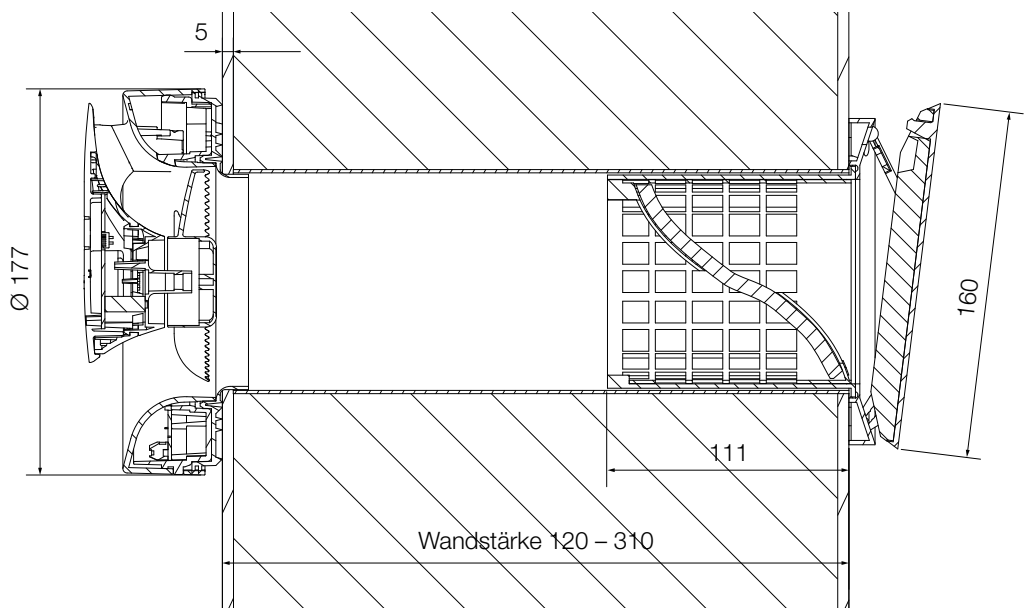



Remarks

To ensure that the system can be installed, observe the minimum clearances shown in the adjacent illustration.
 Minimum wall thickness: 120 mm.

Minimum distances from centre axis core bore

- to components on the inner wall/loib: 250 mm circumferential
- mount in the air volume flow of the room at approx. 1.80 m OKFFB optimally.

All assembly and operating instructions as well as further information can be found at www.inventer.de.

DXF / DWG / STP

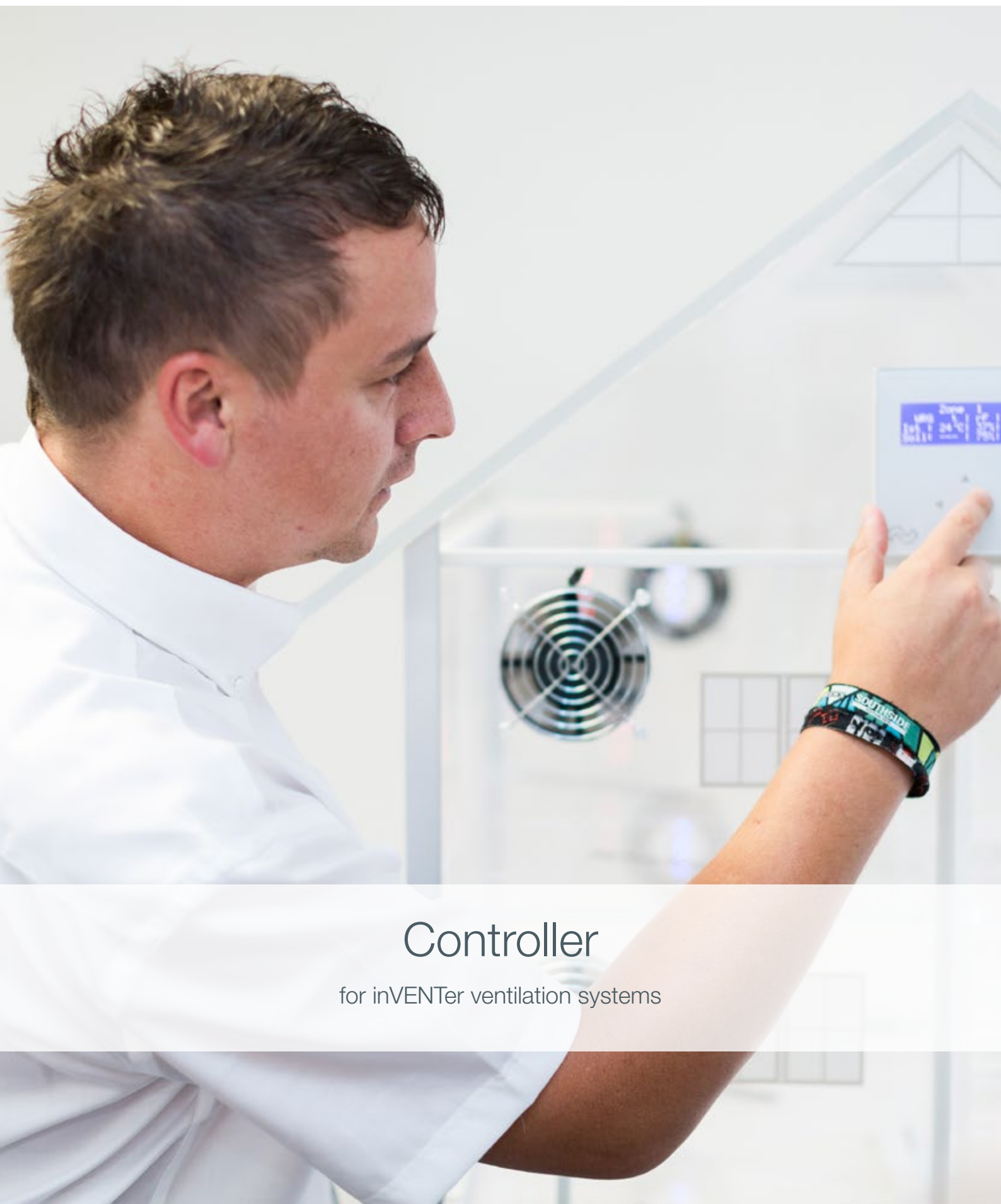

Controller

for inVENTer ventilation systems

sMove controller

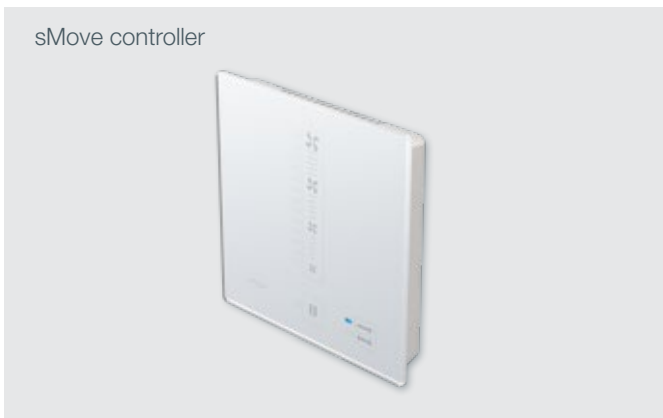

Controller for controlling the inVENTer ventilation units.
sMove s4 4x iV-Smart+, iV14-Zero, iV-Light, iV-Compact or 2x iV-Twin+, iV25
sMove s8 8x iV-Smart+, iV14-Zero, iV-Light, iV-Compact or 4x iV-Twin+, iV25
Switching power supply included (flush-mounted version / control cabinet).
Simultaneous operation and display interface through integrated illuminated displays. Operating modes heat recovery, ventilation and pause/stop. Simple switching between operating modes via capacitive buttons. Air volume flow adjustable in four pre-defined ventilation modes or infinitely variable control via slider controller. Boost function selectable over 15 minutes in all operating modes. With pause function for 1, 2, 4 or 8 hours (both versions). Can also be switched off completely (standard version only). Flat version: Deactivation lock. Operating hours counter available for all variants.
5-year manufacturer's warranty.

The sMove controller can be extended with additional sensors. An external interface allows the connection of a potential-free switching contact. This defines the behaviour of the ventilation system when the connected sensor is activated (ventilation or deactivation of all connected ventilation devices). Integration into an existing house control system via an analogue input is also possible.

Accessories (optional)

- CO₂ Sensor CS1
- Hygrostat HYG18 / Hygrostat HYG12
- Flush-mounted socket 60x66
- Flush-mounted socket 60x90
- Socket dry wall 68x61
- Socket wall mounted 70x87
- Round cable LiYY-O 3x0,75 (33m)

sMove s4/s8 controller

Technical Specifications

| | |
|---|------------------|
| Mains voltage [V AC], [Hz]: | 230, 50 |
| Operating voltage [V DC] | 24 |
| Power consumption while Standby [W] | < 1 |
| Max. power consumption [W] | s4: 10 s8: 20 |
| External switching contact (optional) | |
| Smoke exhaust monitor | Opener |
| Other sensors | Turnkey |
| Protection type | IP20 |
| Protection class | II |
| Dimensions control unit [W x H x D, mm] | 86 x 86 x 24 |

Maximum cable lengths

Operating voltage cable between power supply unit and controller:

max. 100 m

sMove s4 / star-shaped connection

Between controller and iV-Smart+ / iV14-Zero / iV-Light / iV-Compact max. 33 m

Between controller and iV25 / iV-Twin+ max. 25 m

sMove s4 / connection in series / between controller and last ventilation unit

Controller with 4 x iV-Smart+ / iV14-Zero / iV-Light / iV-Compact max. 15 m

Controller with 2 x iV-Smart+ / iV14-Zero / iV-Light / iV-Compact max. 25 m

Controller with 2 x iV25 / iV-Twin+ max. 15 m

sMove s8 / star-shaped connection

Between controller and iV-Smart+ / iV14-Zero / iV-Light / iV-Compact max. 33 m

Between controller and iV25 / iV-Twin+ max. 20 m

sMove s8 / connection in series / between controller and last ventilation unit

Controller with 8 x iV-Smart+ / iV14-Zero / iV-Light / iV-Compact max. 10 m

Controller with 2 x iV-Smart+ / iV14-Zero / iV-Light / iV-Compact max. 20 m

Controller with 2 x iV25 / iV-Twin+ max. 10 m

Example: Star-shaped connection of the ventilation units

(sMove S8 with control cabinet power supply)

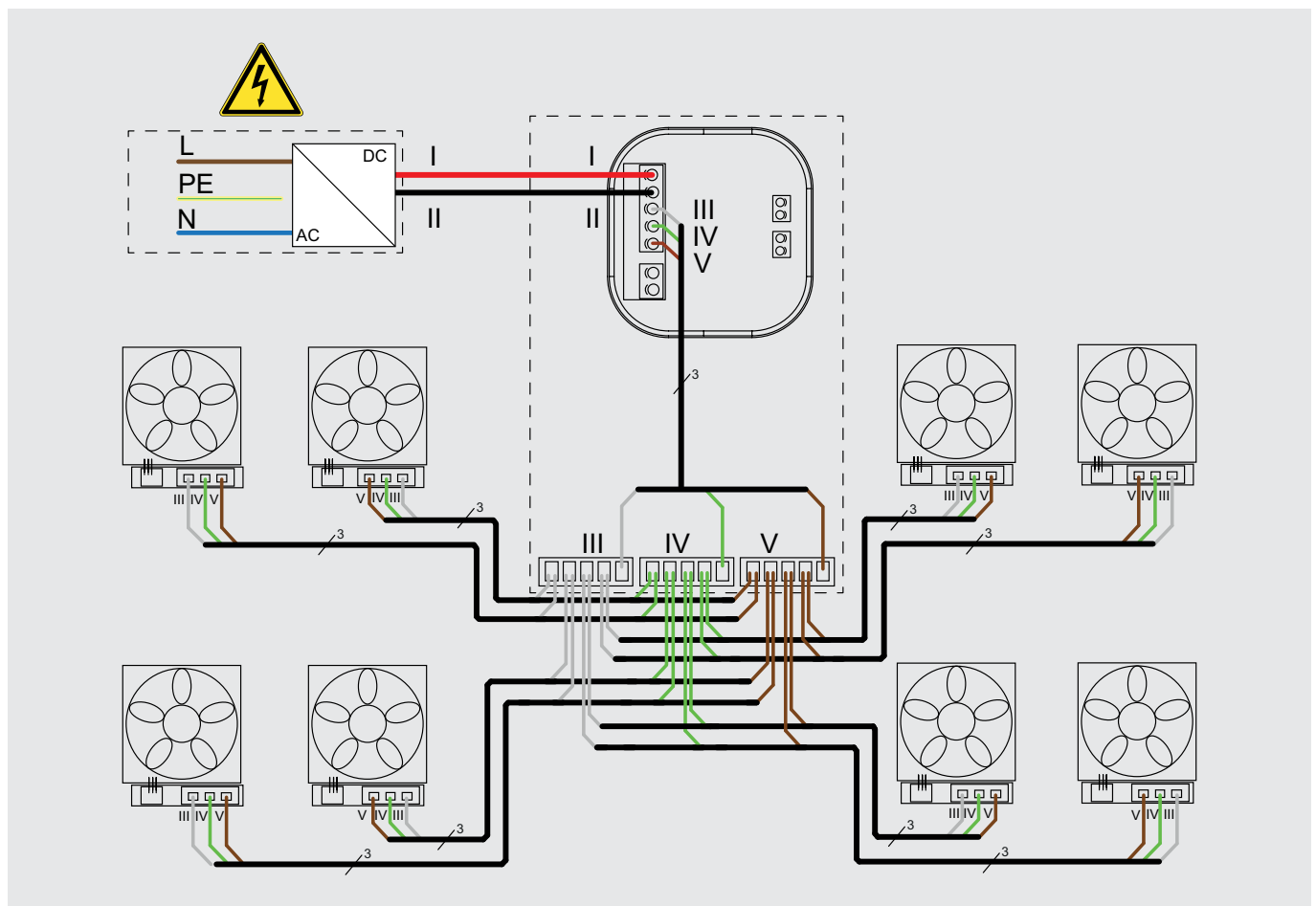

MZ-Home Controller

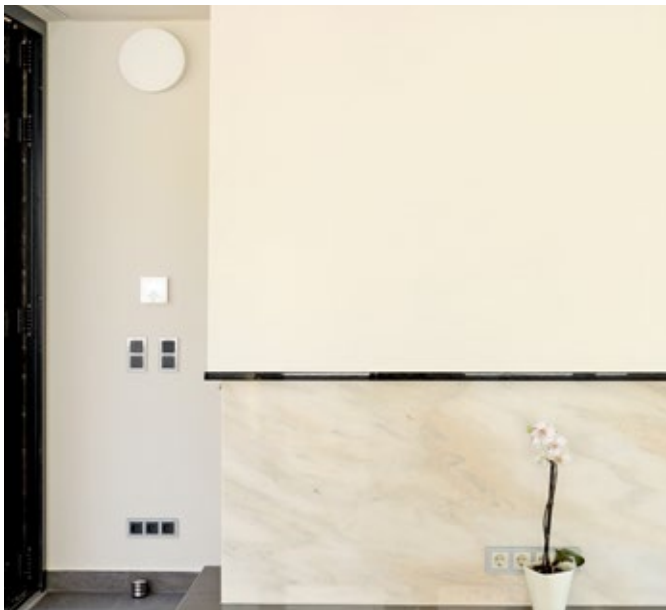

MZ-Home Controller

Multi-zone controller for control of up to 16 x iV14-Zero / iV-Smart+ / iV-Light / iV-Compact or 8 x iV-Twin+ / iV25 in max. 4 different ventilation zones. Definition of ventilation zones via associated Clust-Air® modules.

Basic version MZ-Home contains:

- Controller
- 1x Clust-Air® module incl. humidity and temperature sensor for automatic control
- Switching power supply for control cabinet installation

A ventilation zone comprises 2 - 4 x iV14-Zero / iV-Smart+ / iV-Light / iV-Compact or 1 - 2 x iV-Twin+ or 2x iV25.

Connection of up to 4 Clust-Air® modules in total.

5-year manufacturer's warranty.

Equipment and functions

- Weekly timer
- Capacity display for each zone
- External interface for integration into an existing house control system or for connection of a potential-free switch
- Filter exchange interval display
- Operating hours counter
- Operating modes: Heat recovery, ventilation, pause, dehumidification

Clust-Air®-Module

Module for the implementation of a zone control. Connection to operating unit of the MZ-Home for further control of up to 4 x iV14-Zero / iV-Smart+ / iV-Light / iV-Compact or 2 x iV-Twin+ / iV25.

Humidity/temperature sensor included. Further sensors can optionally be integrated at the external input.

Accessories (optional)

Clust-Air-Module CAM17

CO₂ Sensor CS1

Socket dry wall 68x61

Flush-mounted socket 60x66

Bus cable J-Y(ST)Y2x2x0.8 Lg

Round cable LiYY-O 3x0,75 (33 m)

Functionality Clust-Air technology

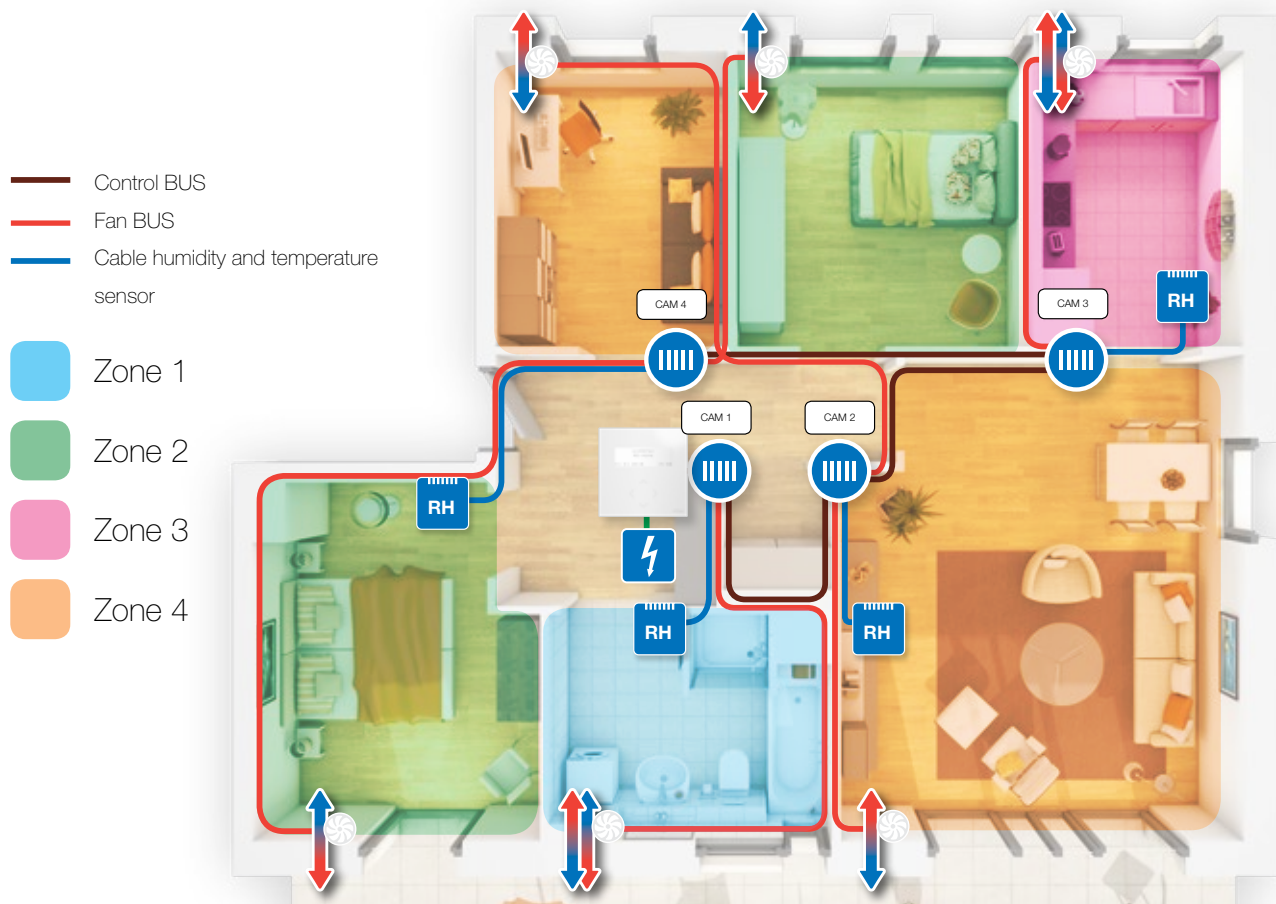

Controller

Planning information

- Division of the residential unit into max. 4 areas (zones) to be ventilated per controller MZ-Home
- Assign ventilation units operated in pairs to the same zone
- Connection of the Clust-Air modules CAM in a row
- Mounting humidity and temperature sensors in the air volume flow of the room

Maximum cable lengths

Operating voltage cable between power supply unit and controller:
max. 100 m

Control BUS

Star connection

Between CAM and iV-Smart+ / iV14-Zero max. 33 m

Between CAM and iV25 / iV-Twin+ max. 25 m

Connection in series / between controller and last ventilation unit

CAM with 4 x iV-Smart+ / iV14-Zero max. 15 m

CAM with 2 x iV-Smart+ / iV14-Zero max. 25 m

Controller with 2 x iV25 / iV-Twin+ max. 15 m

Technical Specifications

Power supply

Mains voltage [V AC], [Hz]: 230, 50

Output [V DC]: 24

Protection class / Protection type II / IP20

Controller

Operating voltage [V DC] 24

Control bus voltage [V DC]: 24

Power consumption max. [W] 0.5 (4 ventilation zones)

Power consumption while Stand-by [W] 2.5 (4 ventilation zones)

Dimensions [W x H x D, mm] 119 x 119 x 27.5

Technical Specifications

Clust-Air-Module CAM17

Operating voltage [V DC] 24

Control bus output voltage [V DC] 24; 4-pole

Fan bus output voltage [V DC] max. 16; 3-pole

Total breaking current [A] max. 0.8

Power consumption [W] max. 18

External switching contact (optional) Potential-free
Turnkey

Analogue input (optional)

Output voltage [V DC] 0 - 10

Resolution [Bit] 10

Schematic diagrams for cable routing

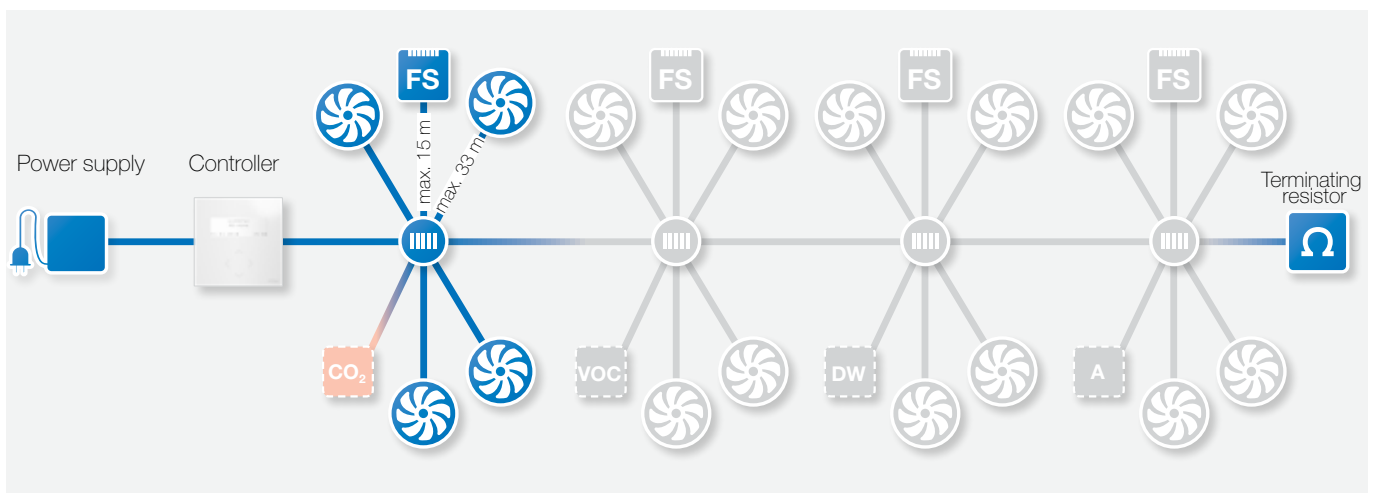
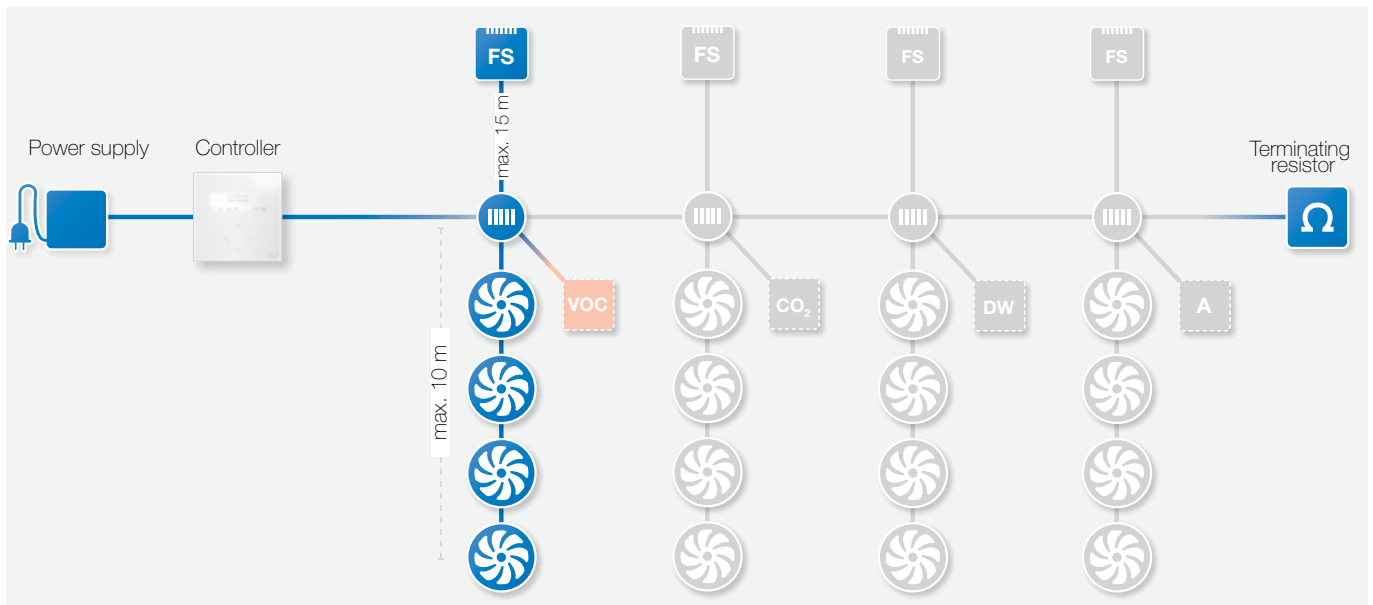

Example: Connection of ventilation units in star/row combination

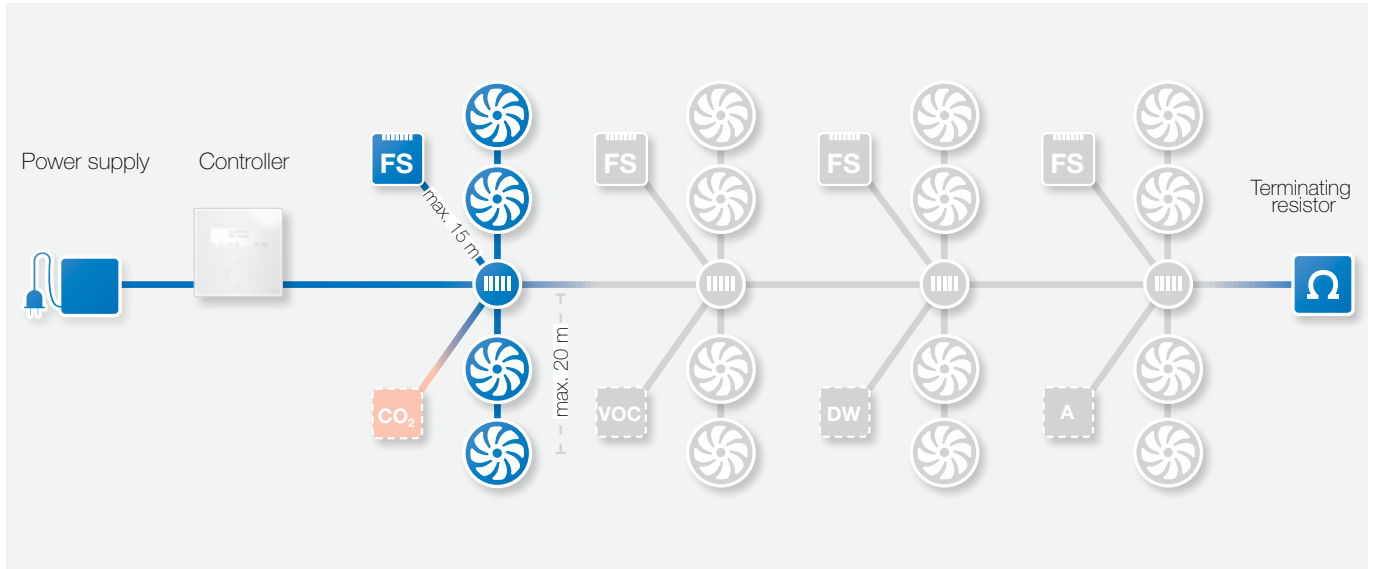

Example: Connection of ventilation units in a row

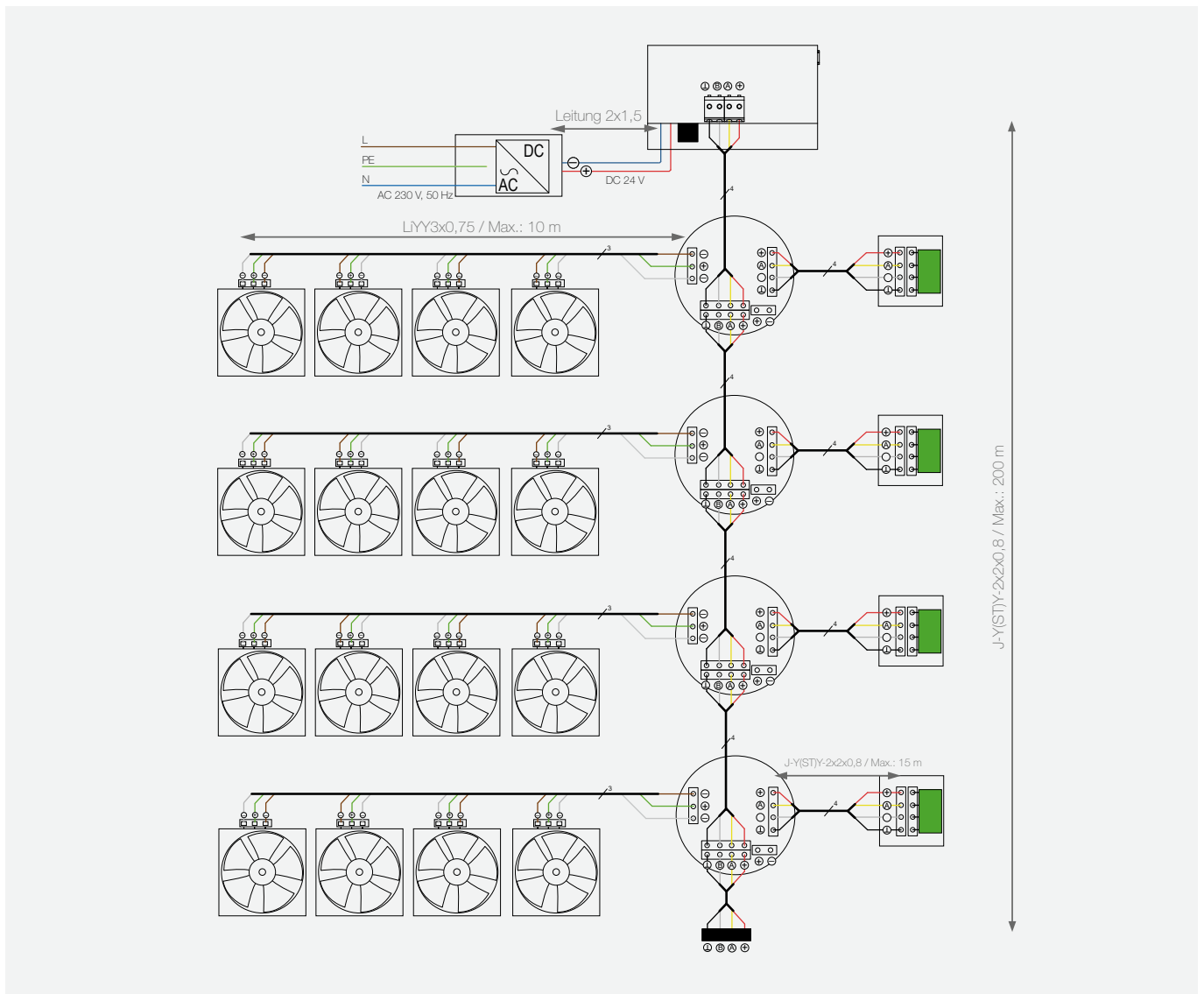

inVENTer Connect Controller System

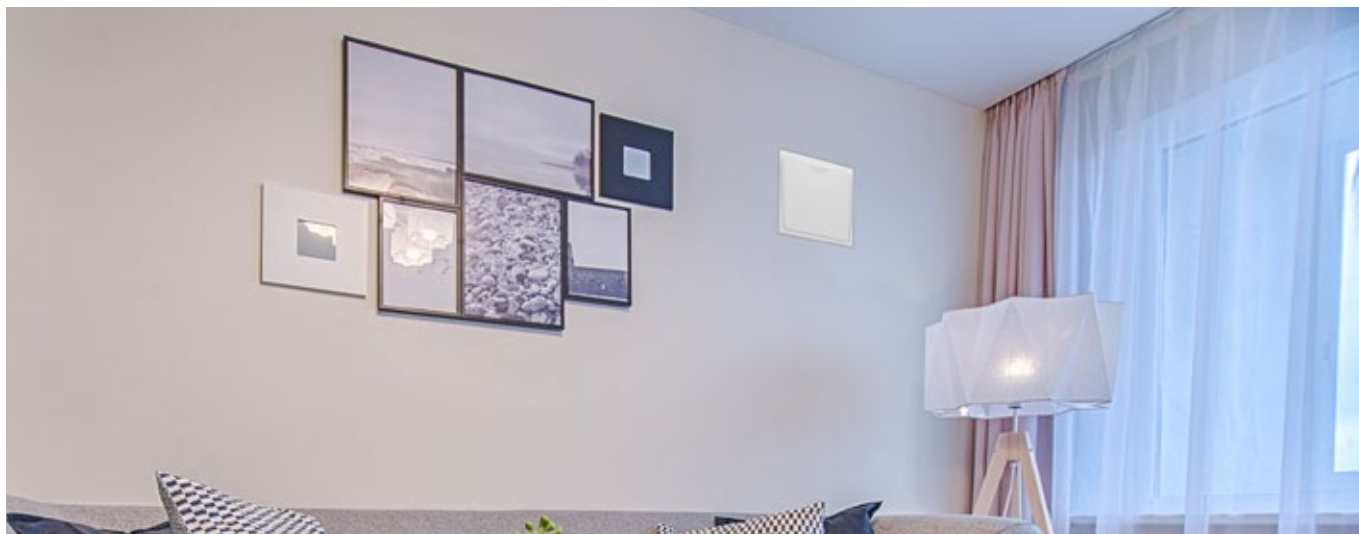

New wireless solution from inVENTer!

- Radio version for wireless control via 868 MHz radio network
- Control and programming with the app "inVENTer Mobile"
- Ventilation profiles for maximum comfort

Realisation

1. The controller system consists of the Connect inner panel and the Easy Connect e16 controller, as well as the Smartphone App inVENTer Mobile.
2. For implementation, the iV ventilation units iV14-Zero, iV-Smart+, iV-Light and iV-Compact are integrated into the external walls and fitted with the new Connect internal panel instead of the standard Flair / Flair SDE or Light internal panel.
3. Power supply: 230V mains voltage to the individual Connect inner panels. It is not necessary to wire the individual devices to each other!
4. Install the Easy Connect e16 controller as the control unit in the usage unit. Power supply: 230V mains voltage.
5. Optional: Equip ventilation zones with sensors (humidity/temperature sensors are battery-operated and can be freely positioned).
6. Commissioning with the App inVENTer Mobile (Android / iOS). Define ventilation zones from the individual devices and sensors.
7. Assign the corresponding ventilation profiles to the individual ventilation zones.

Remarks

- The flush-mounted version of the Connect inner panel is almost flush with the wall
- inVENTer Connect has its own 868 MHz network. An interference with the local WLAN networks is therefore impossible. A WLAN network is not required!
- The Easy Connect e16 controller can manage 16 devices/sensors in up to 4 ventilation zones.
- All sensors are optional, but an outdoor humidity/temperature sensor is required for full functionality (e.g. for summer operation).
- In bedrooms, work rooms and common rooms, CO2 monitoring is useful; alternatively, the CO2 value can also be measured in the overflow area (mixed air value).
- Communication between Smartphone App and Easy Connect e16 controller is via Bluetooth. During operation, basic functions can also be controlled directly via the keys of the Easy Connect e16 controller.

Inner panel Connect

Inner panel Connect



Internal panel for radio-based control and programming of decentralised ventilation systems iV-Smart+, iV14-Zero, iV-Light, iV-Compact. Basis for the integration and use of inVENTer Connect. Flush-mounted / surface-mounted versions. Automatic closing of the inner panel during switch-off or pause.

Replaces the standard inner panels Flair / Flair SDE / Flair Zero or Light on the respective devices.

Technical Specifications

| | |
|---|---------------------------------|
| Dimensions [W x H x D, mm] | 258 x 258 |
| Installation depth flush-mounted version [mm] | + 38 |
| Radio frequency [MHz] | 868 |
| Radio network range [m] | Open field: 100 Building: 30 |
| Mains Voltage [V AC] / [Hz] | 230 / 50 |
| Operating Voltage [V DC] | 24 |
| Fan bus output voltage controller [V DC] | 6.7 - 15.3 |
| Power consumption [W] | 12 |
| Protection Type / Protection Class | IP 52 / II |

Components

Internal insert with automatic closing flap and dust filter G4. Compatible with UP/AP R-D160 housing (iV-Smart+ / iV-Light / iV-Compact) or UP/AP R-D200 housing (iV14-Zero).

Mounting plate with power supply unit, shutter motor for automatic shutter, humidity / temperature sensor and radio technology 868 MHz

Accessories (obligatory)

Wall mounting sleeve R-D160x495 incl. housing IB Connect
Wall mounting sleeve R-D160x745 incl. housing IB Connect
Wall mounting sleeve R-D160x495 incl. housing IB Connect
Wall mounting sleeve R-D160x745 incl. housing IB Connect,
or wall installation system Simplex Connect

Controler Easy Connect e16

Control unit Easy Connect e16



Wireless controller for control and programming of up to 16x Connect internal panels (iV-Smart+, iV14-Zero, iV-Light, iV-Compact) or wireless sensors in max. 4 different ventilation zones. 5-year manufacturer's warranty.

Technical Specifications

| | |
|---|---------------------------------|
| Dimensions control unit [W x H x D, mm] | 88 x 88 x 9 |
| Radio frequency [MHz] | 868 |
| Radio network range | Open field: 100 Building: 30 |
| Mains voltage [V AC]/[Hz]: | 230/50 |
| Operating voltage [V DC] | 24 |
| Power consumption [W] | 1.5 |

Features

Automatic control of individual ventilation zones according to selected ventilation profiles

Demand-driven ventilation via room humidity and via carbon dioxide values, outside temperature and dew point control, if appropriate sensors are used.

Display with indication of air volume flow, ventilation modes, ventilation profiles, indoor humidity/temperature values, outdoor temperature value, indoor air quality, time, system messages, system warnings.

Setting and management of ventilation level, ventilation zones, ventilation profiles, filter change and maintenance intervals. Fast access via keypad.

External input for integration of additional sensors (e.g. pressure switches etc.).

Complete controller components

Control unit with display and mounting plate.

Radio technology 868 MHz for communication with up to 16 internal panels Connect or radio sensors.

Bluetooth module for access via app "inVENTer Mobile" (Android / iOS).

Interface for RS485 data cable as an alternative to the radio version.

Humidity/temperature sensor integrated.

Connection and communication Controller and inner panel Connect

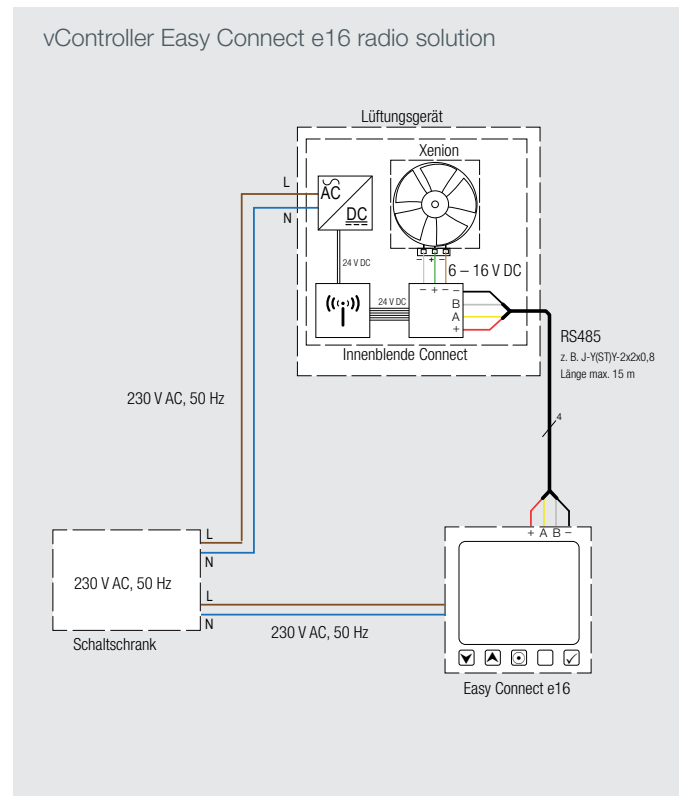
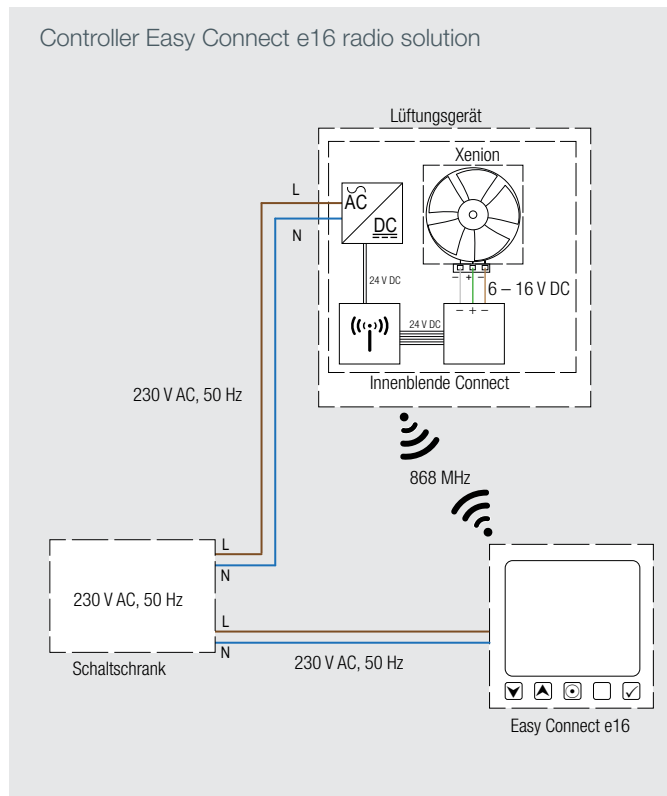

The inVENTer Connect controller platform can be supplemented with additional sensors for displaying and monitoring indoor and outdoor humidity/temperature values as well as CO₂ values. This makes extended demand-led ventilation possible.

Accessories (optional)

Humidity/temperature sensor FTS19-Connect indoor
 Humidity/temperature sensor FTS19-Connect outdoor
 CO₂-Sensor CS2-Connect

Ventilation profiles

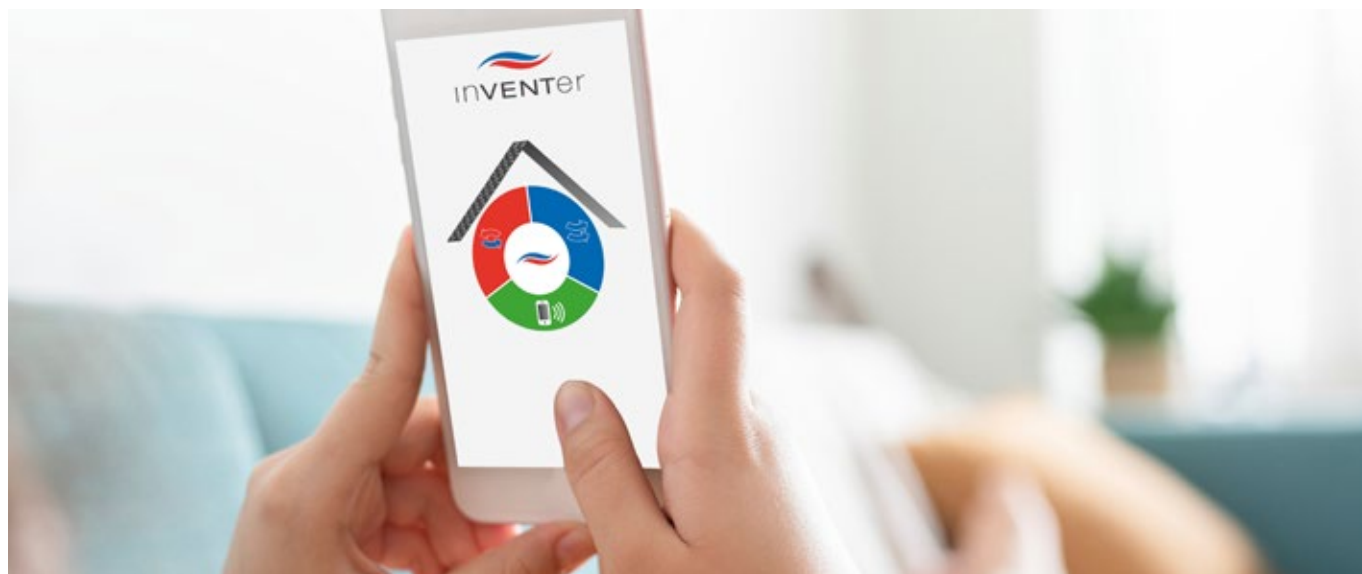

Ventilation profiles are assigned to the individual ventilation areas for maximum comfort and demand-driven ventilation. A ventilation profile is a programmable weekly timer with 3 variables:

- Time (7 days, 24 hours each)
- Ventilation level (levels 1 - 4 or pause)
- Ventilation mode (heat recovery or ventilation or pause)

The following ventilation profiles are pre-programmed with differentiation according to working day and weekend:



Bedroom

Consideration of falling asleep and sleeping times



Children's room

Consideration of children's falling asleep and sleeping times



Bathroom

Consideration of times-of-use



Living-room

Consideration of times-of-use



Kitchen

Consideration of cooking and meal times



Holiday mode

Basic ventilation when the user is absent

All ventilation profiles can be adapted to individual requirements. Default profiles, which can be programmed and saved according to individual requirements, are also available for maximum individualisation.

There are also special ventilation profiles that require an outdoor humidity/temperature sensor: Consideration of falling asleep and sleeping times



Basement ventilation with heat recovery

→ Dew point control



Basement ventilation

→ Dew point control



Summer operation

→ for automatic summer cooling in hot summer months



Exhaust air systems

w/o heat recovery

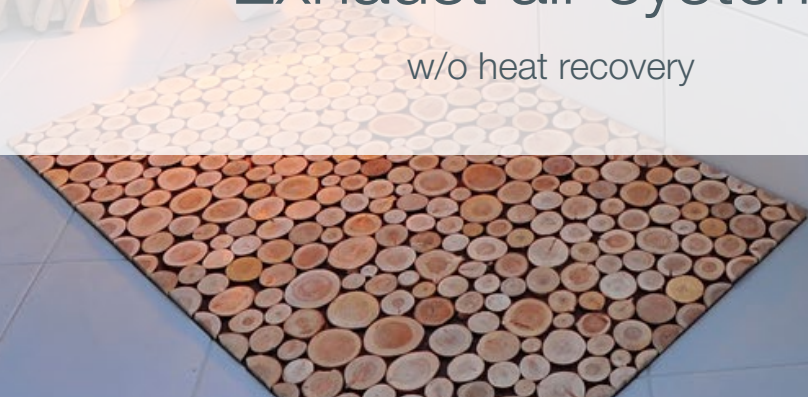

Wall Mounting Kit aV100

Wall mounting set aV100 Standard with Avio N100 / aV100 Corner with Pulsar

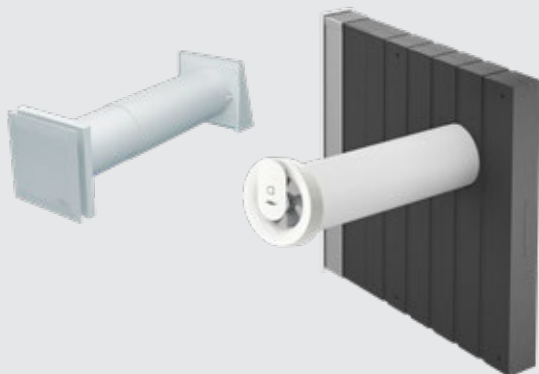

Technical Specifications

| | |
|--|---------------|
| Diameter of wall opening [mm] | 115 |
| Wall thickness [mm] | > 180 |
| Dimensions of weather protection hood [W x H, mm] | 154 x 157 |
| Dimensions of reveal grille [W x H, mm] | 70 x 512 |
| Dimensions of wall mounting sleeve [Ø, length, mm] | 103, 495/745 |
| Dimensions Corner channel [W x H, length, mm] | 60 x 490, 515 |

Wall opening Wall installation set aV100 Standard - Interior view

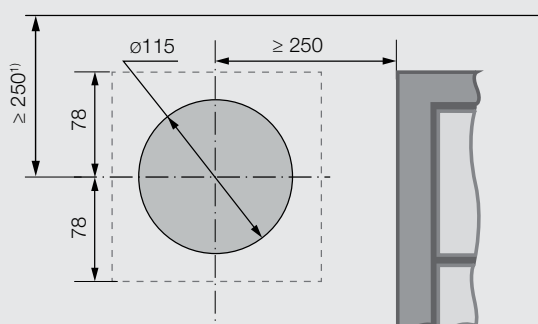

1) Minimum distance to components on the inner wall

Wall opening Wall installation set aV100 Corner

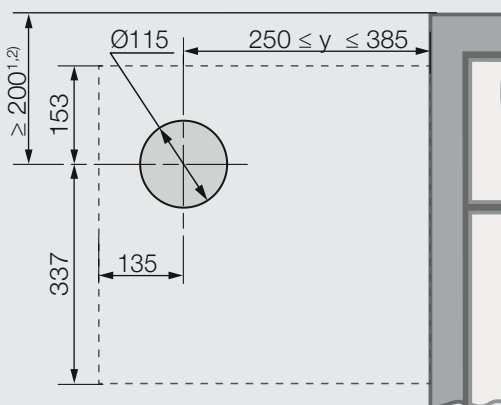

- 1) Minimum distance to components on the inner wall
- 2) Mind the insulation thickness and any roller shutters on the outer wall

Wall Mounting Kit aV100 Description

Wall mounting set for mounting the exhaust fans Avio N 100, Pulsar Basic, Pulsar and Aviant. Without heat recovery.

With integrated noiseless non-return damper. For installation in the outer wall.

With weather protection hood as outer wall termination. Alternatively Corner duct with stainless steel grille as reveal variant for a concealed external finish.

Remarks

When installing, observe the minimum clearances in Figures 2 and 3 to ensure that the system can be installed.

Mount in the air volume flow of the room. The mountable exhaust fans can be installed in the area 1 - 3 according to VDE 0100.

Observe the minimum frontal distance for cleaning the system. Minimum distance to other ventilation systems/components: 1.2 m

Insulation on the flat duct: min. 10 mm

All assembly and operating instructions as well as further information can be found at www.inventer.de

Exhaust Air Unit Avio N 100



Low-noise exhaust air unit for ventilation of damp rooms with outside window.

Wall installation in the wall installation set aV100 or installation in the false ceiling.

Overshoot time adjustable from 5 to 30 minutes. Integration of hygrostat HYG18 / HYG12 for humidity control additionally possible.

Install the ventilation unit in the air volume flow of the room. Integrated air flow cone for flow guidance for particularly quiet operation.

Independent control. Combination with light switch possible or separate operation via switch or push-button.

Dimensions

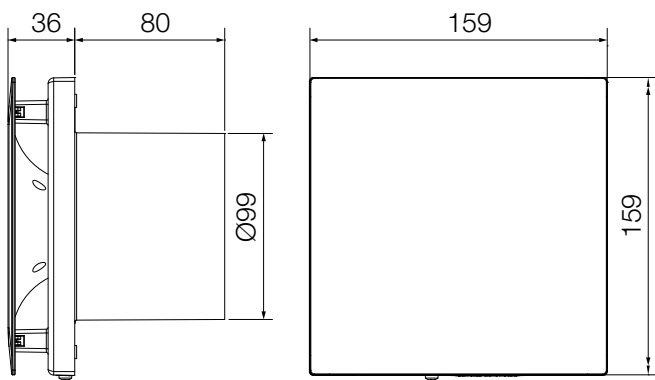

Technical Specifications

| | |
|---------------------------------------|-----------|
| Diameter of wall mounting sleeve [mm] | 100 |
| Exhaust air volume flow [m³/h] | 75 |
| Mains voltage [V AC], [Hz]: | 230, 50 |
| Power consumption [W] | 6.4 |
| Sound pressure level [dB (A)] | 28 |
| Dimensions of inner panel [W x H, mm] | 159 x 159 |
| Protection type | IP44 |
| Protection class | II |
| Protection range | 1 - 3 |

Exhaust air systems

Connection diagrams

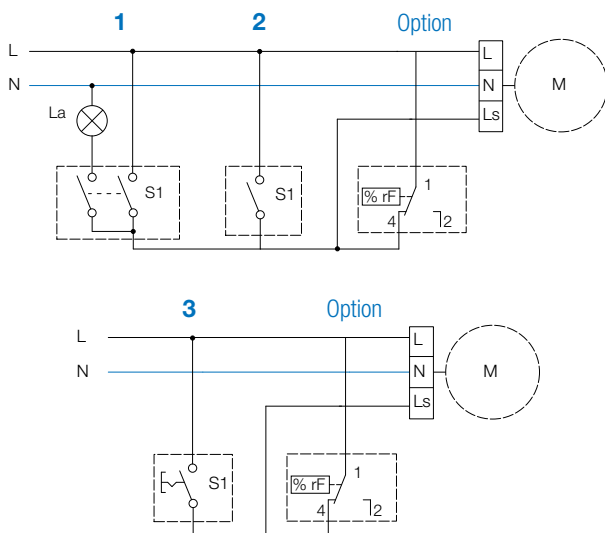

Air volume flow-pressure curve

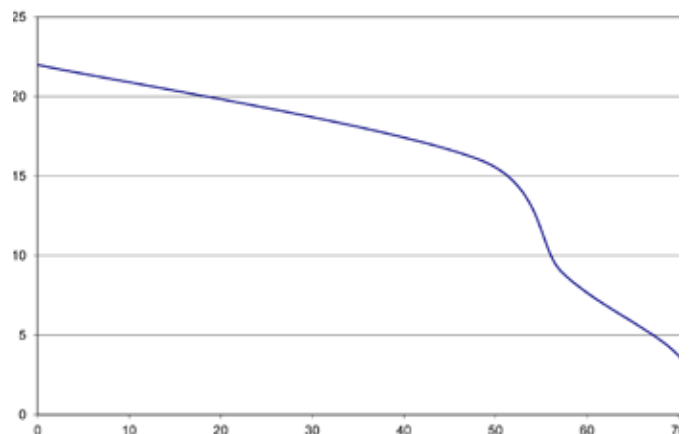

Exhaust Air Unit Pulsar Basic

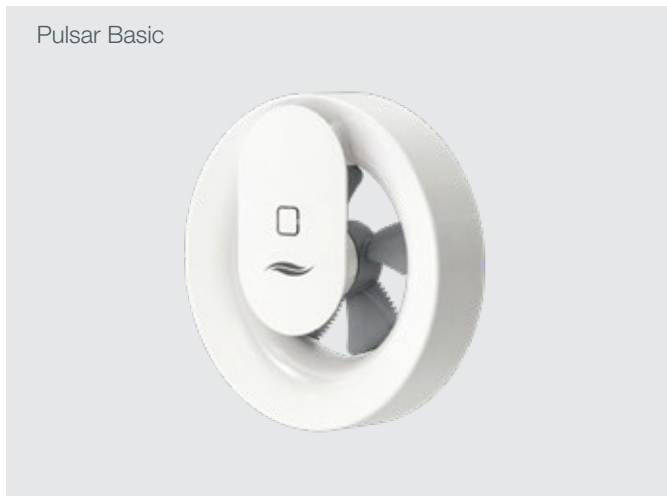

Low-noise exhaust air unit for wall installation with the wall installation set aV100 or installation in the false ceiling.

Easily accessible fan unit for easy cleaning. Meets mechanical safety requirements according to DIN EN 60335-2-80. May be installed in areas 1 to 3 in bath and shower rooms according to VDE 0100.

Autonomous control. Sensor for automatic humidity monitoring. Boost function for peak humidity loads.

Light sensor for ventilation in changing lighting conditions.

With 15 minute time delay.

Permanent operation for continuous ventilation possible.

5-year manufacturer's warranty.

Dimensions

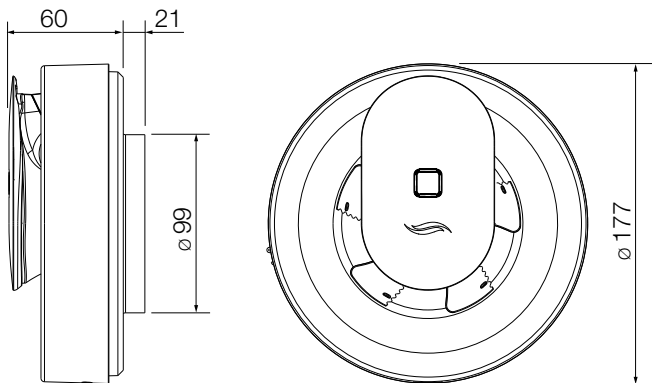

Technical Specifications

| | |
|---------------------------------------|--------------|
| Diameter of wall mounting sleeve [mm] | 100 - 140 |
| Exhaust air volume flow [m³/h] | 110 |
| Input voltage [[V AC, Hz / V DC] | 230, 50 / 12 |
| Power consumption [W] | 4 |
| Sound pressure level [dB (A)] | 17 - 20 |
| Protection type | IP44 |
| Protection class | II |
| Protection range | 1 - 3 |

Connection diagrams

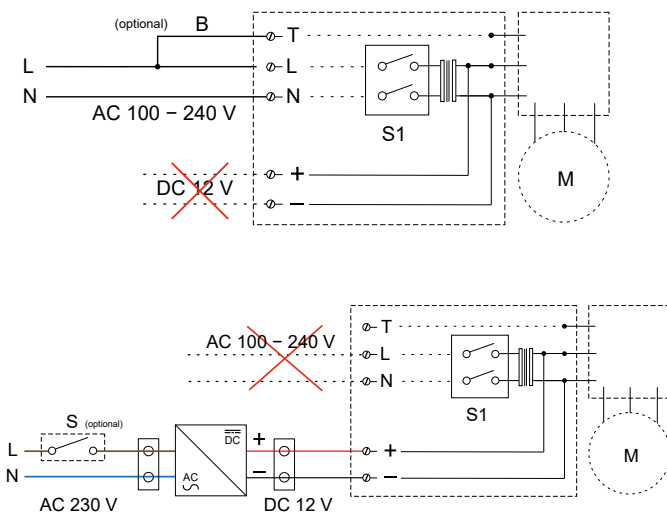

Air volume flow-pressure curve

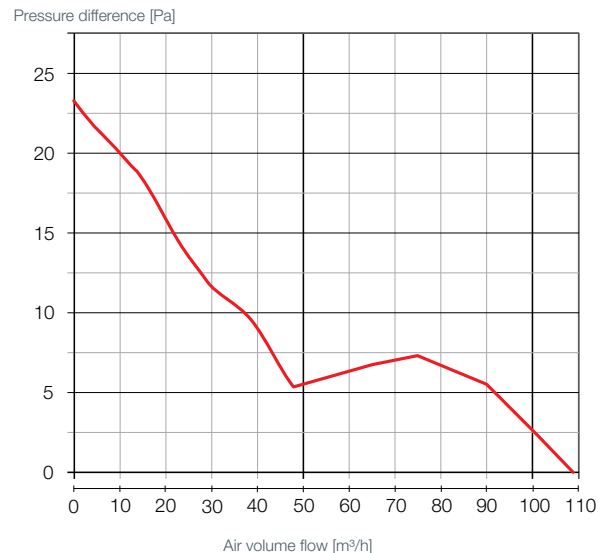

Exhaust Air Unit Pulsar



Fig. 1: Pulsar

Low-noise exhaust air unit for wall installation with the wall installation set aV100 or installation in the false ceiling. With app control (iOS, Android). Integrated humidity sensor and light sensor.

Control of ventilation intensity and settings for humidity and light sensor, time delay and pause times via "inVENTer Mobile"

Power supply via mains voltage (230 V, 50 Hz) or safety extra-low voltage (12 V DC) possible. Power supply unit for safety extra-low voltage connection optionally available.

Meets mechanical safety requirements according to DIN EN 60335-2-80. May be installed in areas 1 to 3 in bath and shower rooms according to VDE 0100..

5-year manufacturer's warranty.

Download App inVENTer Mobile:



You can find detailed information about the requirements for the operating system in the stores and on www.inventer.de

Dimensions

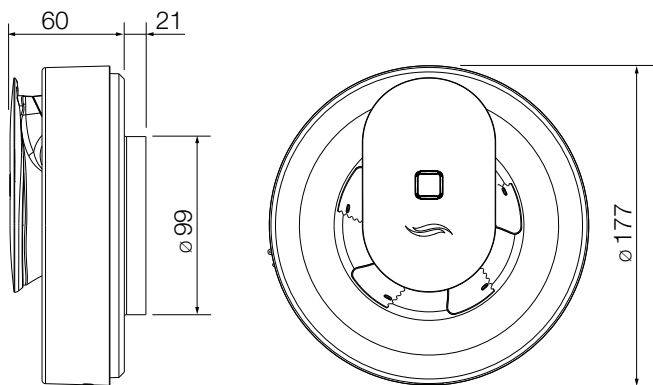

Technical Specifications

| | |
|---------------------------------------|--------------|
| Diameter of wall mounting sleeve [mm] | 100 - 140 |
| Exhaust air volume flow [m³/h] | 110 |
| Input voltage [[V AC, Hz / V DC] | 230, 50 / 12 |
| Power consumption [W] | 4 |
| Sound pressure level [dB (A)] | 17 - 20 |
| Protection type | IP44 |
| Protection class | II |
| Protection range | 1 - 3 |

Exhaust air systems

Connection diagrams

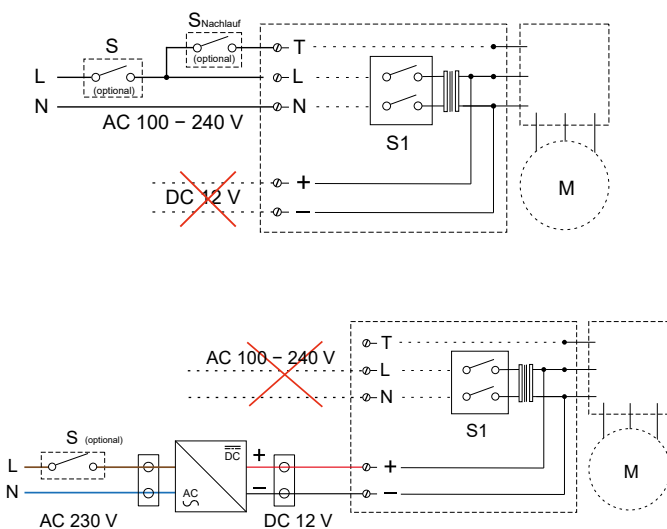

Air volume flow-pressure curve

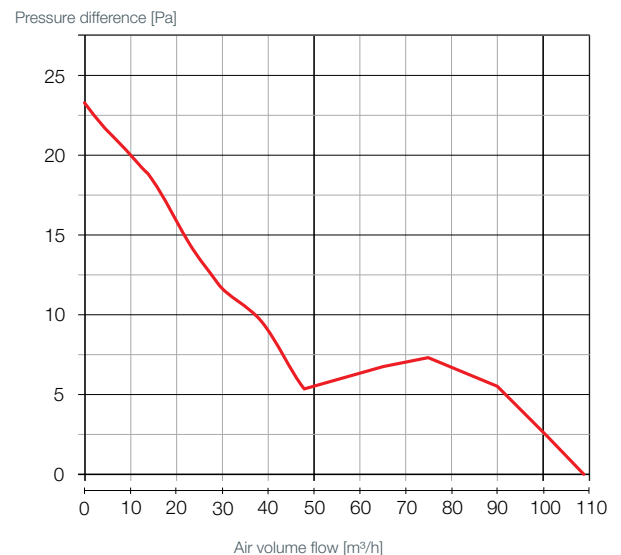

Exhaust Air Unit Aviant



Low-noise exhaust air unit for wall installation with the wall installation set aV100 or installation in the false ceiling.

Easily accessible fan unit for easy cleaning. Meets mechanical safety requirements according to DIN EN 60335-2-80. May be installed in areas 1 to 3 in bath and shower rooms according to VDE 0100..

Autonomous control. Sensor Trio: Damp, light, odour
Target gases of the odour sensor: Methane, Hydrogen, Isobutane, Ethanol

Adjustment of the sensor sensitivity.

Basic ventilation cycles at 26 hour in idle mode

Permanent operation for continuous ventilation possible.

5-year manufacturer's warranty.

Download App
inVENTer Mobile:



You can find detailed information about the requirements for the operating system in the stores and on www.inventer.de

Dimensions

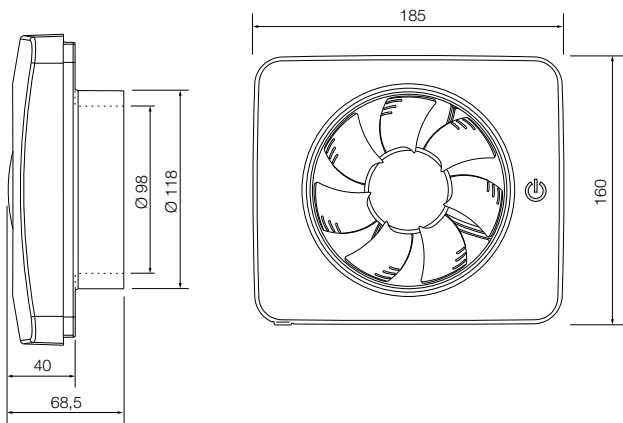

Technical Specifications

| | |
|---------------------------------------|-------------------|
| Diameter of wall mounting sleeve [mm] | 100 / 125 |
| Exhaust air volume flow [m³/h] | 95 / 115 (w/o IB) |
| Mains voltage [V AC], [Hz]: | 230, 50 |
| Power consumption [W] | 5 |
| Sound pressure level [dB (A)] | 17 - 20 |
| Protection class | IP44 |
| Protection class | II |
| Protection range | 1 - 3 |

Connection diagrams

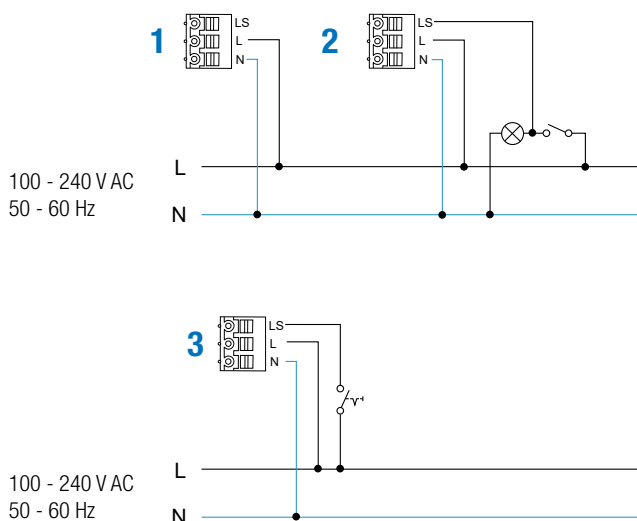

Air volume flow-pressure curve

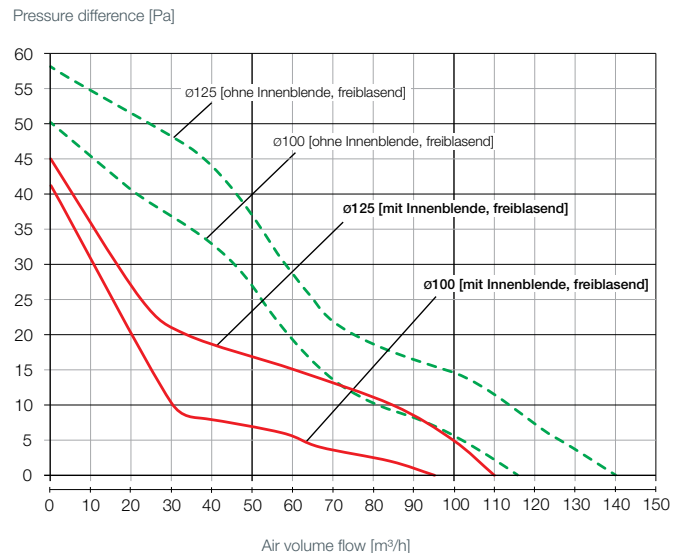

Exhaust Air Unit Aventus



Exhaust air unit for ventilation of interior damp rooms without external window (DIN 18017-3). Without heat recovery. Autonomous control. Suitable for extracting exhaust air to the outside or integration in exhaust air system (multi-storey). Automatic demand-driven air volume flow control via sensors. Permissible installation in area 1 in bath and shower rooms according to VDE 0100.

Installation in supply duct, ceiling or on the wall possible. Optionally with secondary room connection. Selectable control electronics with overrun function and switch-on delay. Also available with humidity sensor.

Fan insert with exhaust air volume flow:

- Single-stage 60 m³/h
- Two-stage 30/60 m³/h (suitable for permanent operation)
- Single-stage 100 m³/h

5-year manufacturer's warranty.

Components

- Fan insert with fan, G2 dust filter and internal screen
- Time delay control and switch-on delay
- Optional: Humidity sensor, second room connection, fire protection accessories
- Fan housing with leak-proof non-return damper
- Available housing variants:
 - Flush-mounted (UP) Radial
 - Flush-mounted (UP) Radial fire protection
 - Flush-mounted (UP) Radial Slim
 - Surface-mounted (AP) Axial

Technical Specifications

| | |
|---|-----------------|
| Dimensions housing Aventus UP [W x H x D, mm] | 255 x 255 x 105 |
| Dimensions housing Aventus UP Slim [W x H x D, mm] | 245 x 245 x 83 |
| Dimensions Housing Aventus UP Fire protection [W x H x D, mm] | 255 x 255 x 95 |
| Dimensions housing Aventus AP [W x H x D, mm] | 260 x 260 x 130 |
| Dimensions of inner panel [W x H, mm] | 260 x 260 |
| Exhaust air volume flow [m³/h] | max. 100 |
| Mains voltage [V AC], [Hz]: | 230, 50 |
| Power consumption [W] | 7 - 24 |
| Sound pressure level [dB (A)] | 30 - 46 |
| Protection Type / Protection Class | IPX5 / II |

Accessories (optional)

Hygrostat HYG18 / HYG12, aV100 Wall installation set, Mounting Bracket MB1, Fire dampers, Inner Panel second room
Fire protection components meet class K90 according to DIN EN 18017-3

Air volume flow-pressure curve

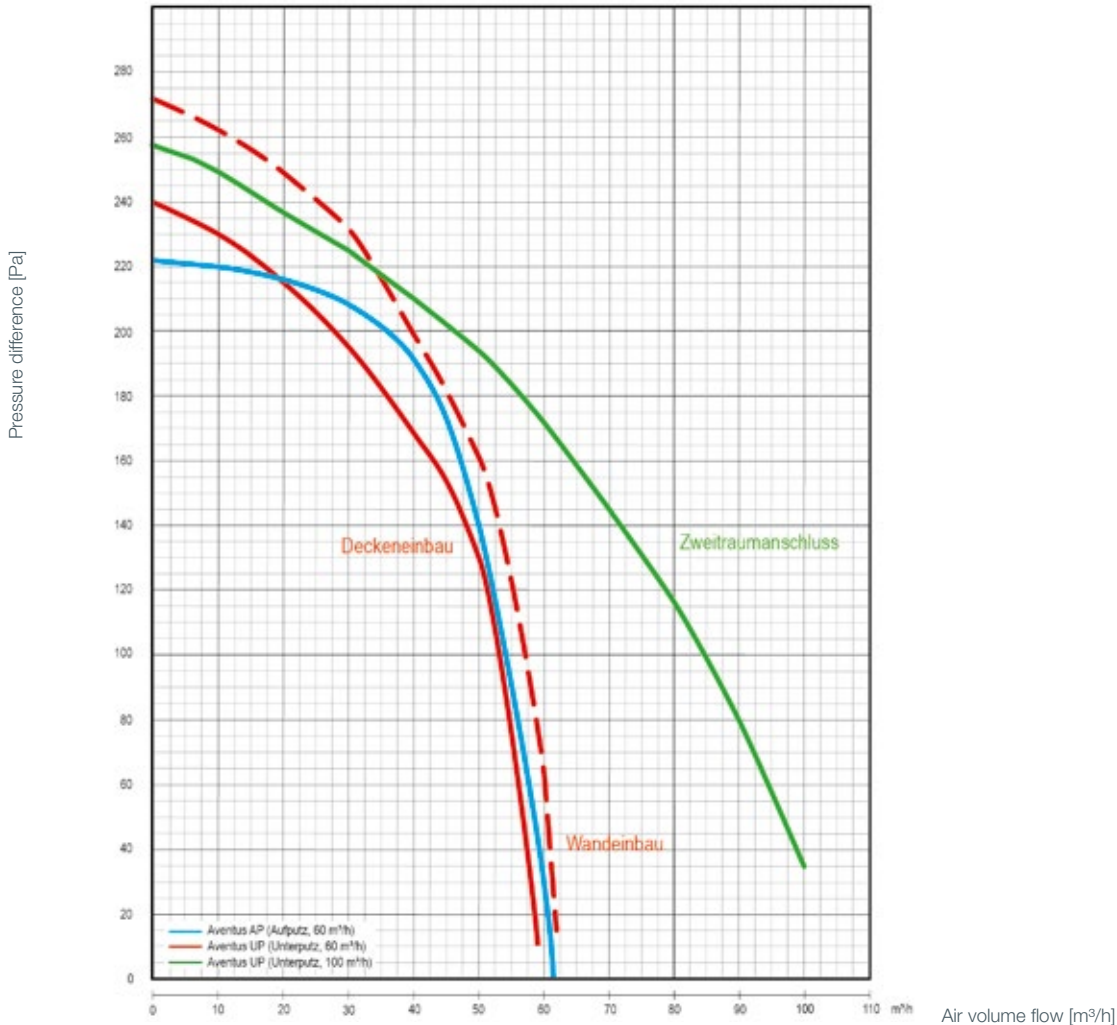

Notes on ventilation planning according to DIN EN 18017-3

Air Volume Flows

Systems for the ventilation of sanitary rooms such as bathrooms and restrooms can be designed for the following minimum air volume flows (depending on the type of design and mode of operation):

40 m³/h: To ensure sufficient ventilation, this air volume flow must be discharged over a period of at least 12 hours per day.

60 m³/h: The air volume flow can be reduced to 0 m³/h if it is ensured that a further 5 m³ of air is discharged from the room to be ventilated via the ventilation unit or exhaust air valve after each switch-off.

According to DIN EN 18017-3, the air volume flow can be up to 15 % below the scheduled volume flow when several ventilation units are operated simultaneously in the supply shaft and due to external influences.

After-flow openings

For optimum functioning of the exhaust air unit and to avoid negative pressure in the room, it must be ensured that the extracted air volume can flow into the supply air.

Supply air: Each internal room to be ventilated must have an unclosable air vent with a free cross-section of at least 150 cm² in order to ensure an adequate supply of air.

Exhaust air: The exhaust air should be exhausted as close as possible to the ceiling into the riser pipe or directly to the outside. In bathrooms, the exhaust air and supply air units must be positioned in such a way that no draughts (air volume flows above 0.2 m/s) occur in the zone occupied by the user.

The air intake openings can be designed as simple fresh air diffusers, e.g. aV100 ALD. From an energetic point of view, it is recommended that ventilation units with heat recovery be provided as air inlet openings.

Integration of the Aventus into central supply ducts (storey building)

- Use of the two-stage fan insert.
- When dimensioning the vertical main line, assume that all connected units have full capacity at the same time.
- When several apartments on one floor are connected to one main pipe, fire dampers are required on the ventilation units.
- The riser/connecting pipe, including the necessary branch pieces and its diameter, must be dimensioned according to the number of floors and devices using the string diagrams. Distortions, narrowed cross-sections or a blow-out pipe of more than 1.5 m above the top unit lead to increased pressure losses. This must be compensated by a larger diameter of the riser pipe.
- Exhaust air ducts must be tight, stable and made of fire-resistant material (DIN 4102:A) for more than two full storeys. They must be designed or thermally insulated in such a way as to prevent damage caused by condensation. The exhaust pipe must be routed over the roof!
- To prevent the transmission of structure-borne noise, the main pipe (supply shaft) must be fixed with noise-damping pipe clamps. The design and installation of the ventilation systems must comply with the building acoustics requirements.
- Provide cleaning openings with tight closures so that the exhaust air ducts can be cleaned easily. A sufficient number of

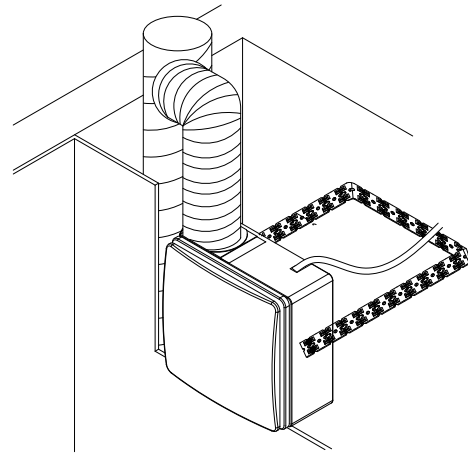

cleaning openings must be guaranteed. Screw-in cleaning caps are not permitted.

- Connect a maximum of two ventilation units per floor to a common supply shaft.
- No other rooms in an apartment may be connected to a ventilation unit which vents the bathroom and restroom.
- When connecting to the pipe system, the bending radius (R) must not be less than the pipe diameter (DN)!

String diagrams for dimensioning the Aventus AP surface-mounted variants

Prerequisite: Floor height: 2.75 m
Roof exit: 1.50 m



Air volume flow 60 m³/h - Pressure difference 88 Pa

2 exhaust air units per floor

1 exhaust air unit per floor

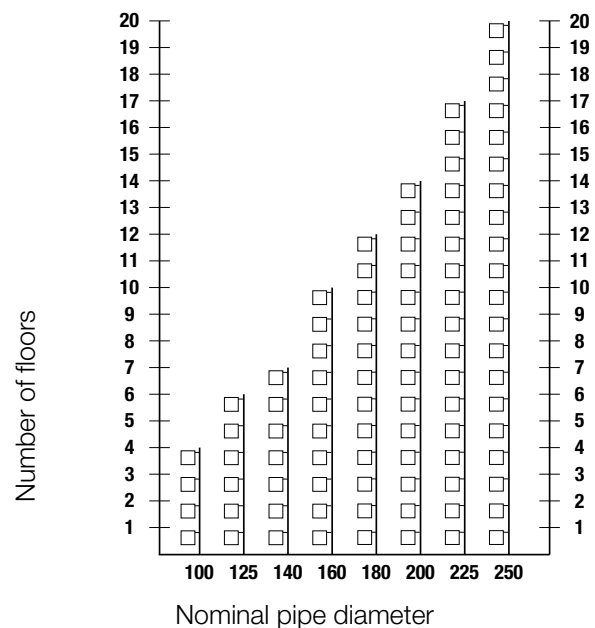
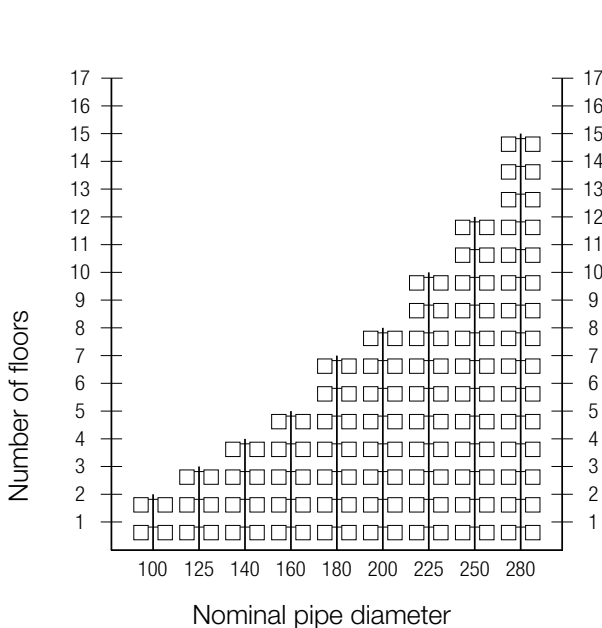

String diagrams for dimensioning the Aventus AP flush-mounted variants



Prerequisite: Floor height: 2.75 m
Roof exit: 1.50 m

Air volume flow 60 m³/h - Pressure difference 118 Pa

2 exhaust air units per floor

1 exhaust air unit per floor

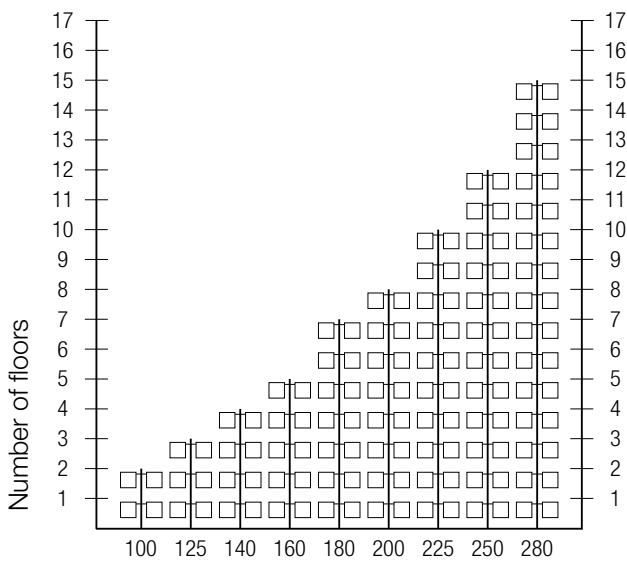

Nominal pipe diameter

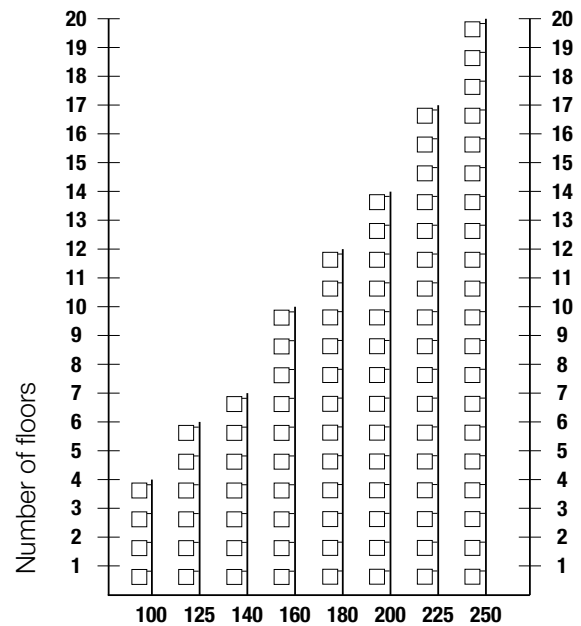

Nominal pipe diameter

Air volume flow 100 m³/h - Pressure difference 60 Pa

2 exhaust air units per floor

1 exhaust air unit per floor

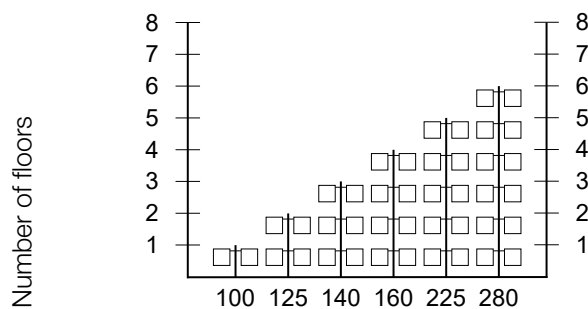

Nominal pipe diameter

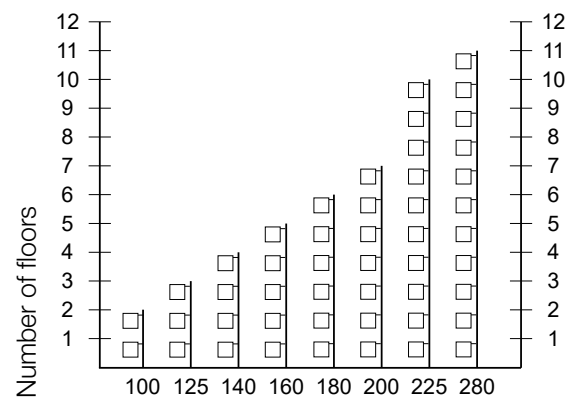

Nominal pipe diameter

Fresh Air Diffuser aV100 ALD



NaV100 ALD Interior view complete system

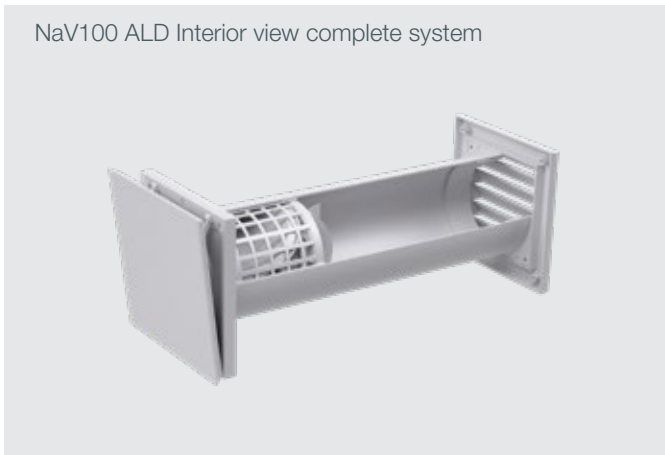

Technical Specifications

| | |
|---|-----------|
| Minimum wall thickness incl. plaster [mm] | 150 |
| Diameter of wall opening [mm] | 115 |
| Diameter of wall mounting sleeve [mm] | 103 |
| Air volume flow [m³/h at 4 Pa] | 7 - 15 |
| Air volume flow [m³/h at 8 Pa] | 14 - 22 |
| Standard sound level difference [dB] ¹ | 33 - 49 |
| Dimensions of inner cover [W x H, mm] | 160 x 160 |
| Dimensions of weather protection grille [W x H, mm] | 150 x 150 |

¹⁾ depending on sound insulation accessories

Fresh air diffuser for controlled supply air post-flow in decentralised exhaust air systems without heat recovery. For new construction and renovation for easy integration into exterior walls. Alternatively Corner duct with stainless steel grille as reveal variant for a concealed external finish.

Components

- ALD insert with insulated angled inner panel
- Filter cartridge with dust filter G1 and wind protection.
- Circular wall mounting sleeve
- Weather protection louvre with lamella opening

Accessories (optional)

- Pollen filter G3, Flicker filter F7
- Wall mounting block D120 or Simplex R-D103
- Soundproofing accessories

Resistance characteristic

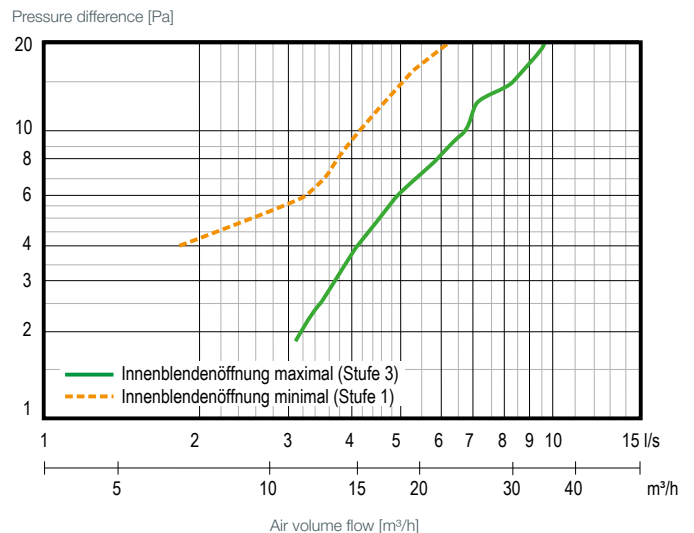

Fresh Air Diffuser aV100 ALD Plus



aV100 ALD Plus Interior view complete system

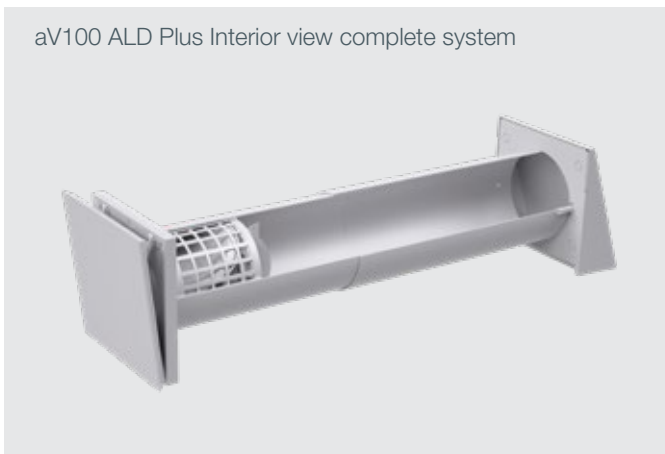

Technical Specifications

| | |
|---|-----------|
| Minimum wall thickness incl. plaster [mm] | 150 |
| Diameter of wall opening [mm] | 115 |
| Diameter of wall mounting sleeve [mm] | 103 |
| Air volume flow [m ³ /h at 4 Pa] | 7 - 15 |
| Air volume flow [m ³ /h at 8 Pa] | 14 - 22 |
| Standard sound level difference [dB] ¹ | 34 - 48 |
| Dimensions of inner cover [W x H, mm] | 160 x 160 |
| Dimensions of weather protection hood [W x H, mm] | 154 x 157 |

¹⁾ depending on sound insulation accessories

Fresh air diffuser for controlled supply air post-flow in decentralised exhaust air systems without heat recovery. For new construction and renovation for easy integration into exterior walls. Alternatively Corner duct with stainless steel grille as reveal variant for a concealed external finish.

Components

- ALD insert with insulated angled inner panel
- Filter cartridge with dust filter G1 and wind protection.
- Circular wall mounting sleeve
- Weather protection hood with protective grille (rainproof)

Accessories (optional)

- Pollen filter G3, Flicker filter F7
- Wall mounting block D120 or Simplex R-D103
- Soundproofing accessories

Resistance characteristic

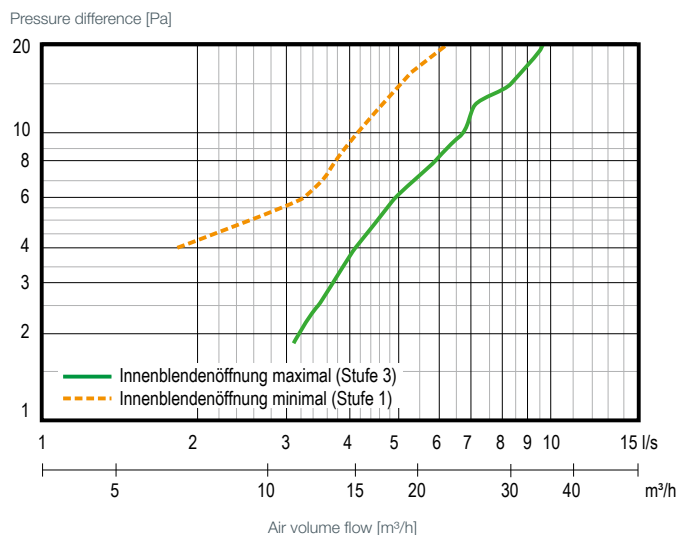

Fresh Air Diffuser aV160 ALD Light

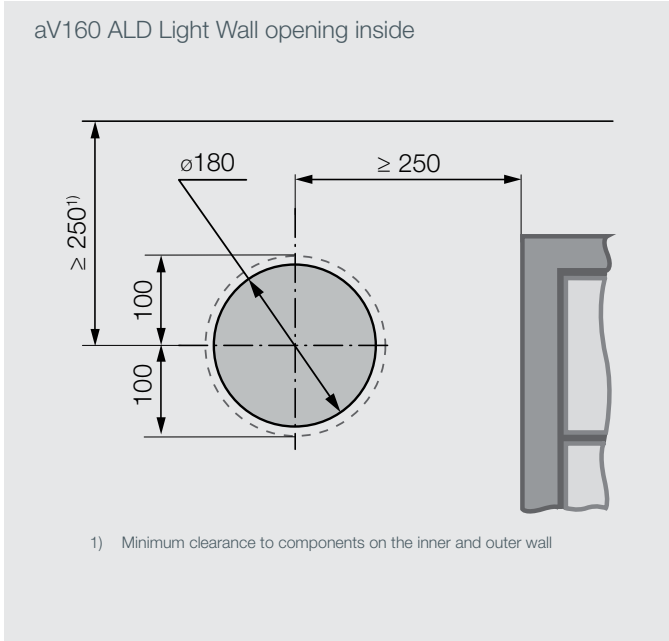

Technical Specifications

| | |
|--|-----------|
| Minimum wall thickness incl. plaster [mm] | 150 |
| Diameter of wall opening [mm] | 180 |
| Diameter of wall mounting sleeve [mm] | 160 |
| Air volume flow [m³/h at 4 Pa] | 12 - 18 |
| Air volume flow [m³/h at 8 Pa] | 18 - 24 |
| Standard sound level difference [dB] ¹⁾ | 51 - 52 |
| Dimensions of inner cover [W x H, mm] | 180 x 180 |
| Dimensions of weather protection grille [ø, mm] | 200 |

¹⁾ depending on sound insulation accessories

Fresh air diffuser for passive supply air post-flow in decentralised exhaust air systems without heat recovery. Sound insulation variant for new construction and renovation for easy integration into external walls. Later upgrade to ventilation system iV-Light possible (for wall thickness ≥ 290 mm).

Components

- ALD insert with insulated square inner panel, lockable by pressure actuation. Supply air regulation in stages.
- Filter cartridge with dust filter G1 and wind protection.
- Circular wall mounting sleeve \varnothing 160 with sound insulation lining
- Circular weather protection grille with lamella opening and fastening claws for quick installation

Accessories (optional)

- Pollen filter G3, Flimmer®-Filter F7
- Wall mounting block D180 or Simplex R-D160

Resistance characteristic

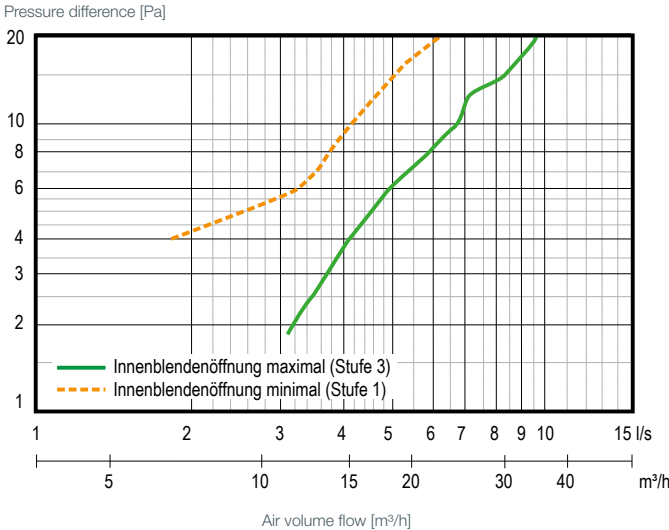

Fresh Air Diffuser aV160 ALD Plus

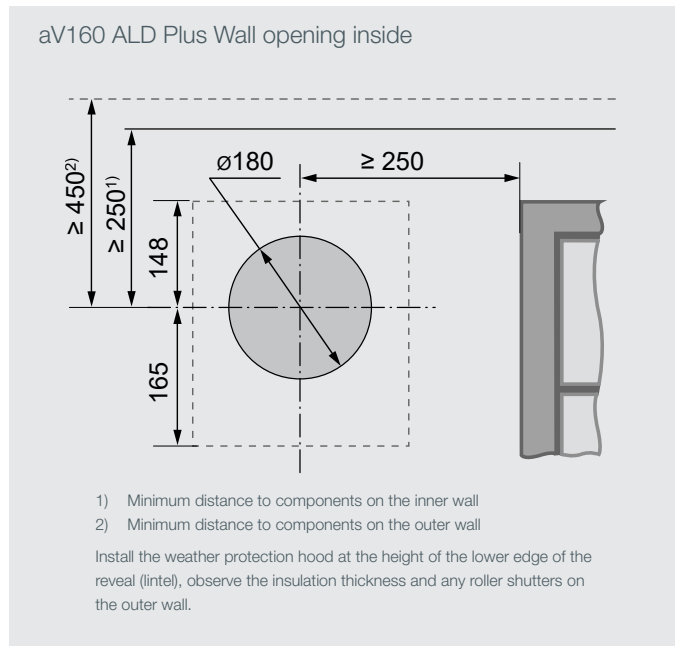

Technical Specifications

| | |
|--|-----------|
| Minimum wall thickness incl. plaster [mm] | 150 |
| Diameter of wall opening [mm] | 180 |
| Diameter of wall mounting sleeve [mm] | 160 |
| Air volume flow [m³/h at 4 Pa] | 13 - 17 |
| Air volume flow [m³/h at 8 Pa] | 19 - 23 |
| Standard sound level difference [dB] ¹⁾ | 54 - 55 |
| Dimensions of inner cover [W x H, mm] | 180 x 180 |
| Dimensions of weather protection hood [W x H, mm] | 279 x 313 |

¹⁾ depending on sound insulation accessories

Fresh air diffuser for passive supply air post-flow in decentralised exhaust air systems without heat recovery. Sound insulation variant for new construction and renovation for easy integration into external walls. Later upgrade to ventilation system iV-Light possible (for wall thicknesses ≥ 270 mm).

Components

- ALD insert with insulated square inner panel, lockable by pressure actuation. Supply air regulation in stages.
- Filter cartridge with dust filter G1 and wind protection.
- Circular wall mounting sleeve \varnothing 160 with sound insulation lining
- Weather protection hood with protective grille (rainproof)

Accessories (optional)

- Pollen filter G3, Flimmer®-Filter F7
- Wall mounting block D180 or Simplex R-D160

Resistance characteristic

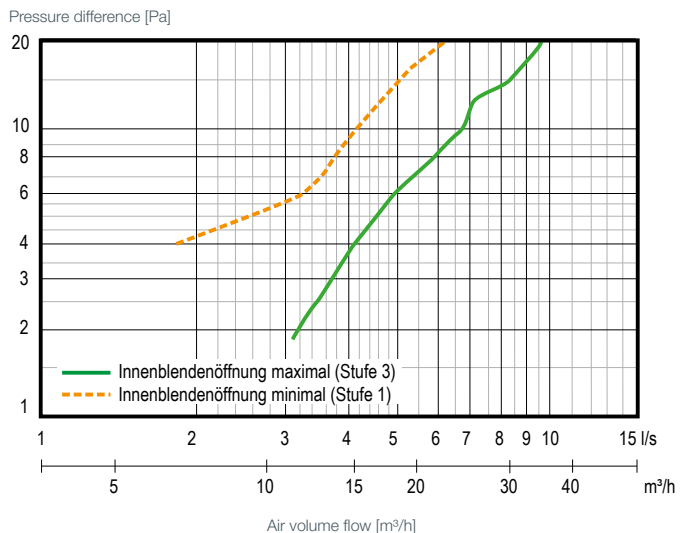



Accessories

for inVENTer products

inVENTer accessories

Soundproofing

Sound-insulating insert

For reducing external noise. Special foam as insert in wall mounting sleeve. For ventilation units iV-Smart+, iV14-Zero, iV-Light, iV-Twin+, iV25, and aV100 ALD.

Sound protector SPR

Insulating element to reduce external and fan noise by deflecting the air volume flow. Installation in wall mounting sleeve. For ventilation units iV-Smart+, iV14-Zero, iV-Light and iV-Twin+.

Sound insulation insert SDE

For increased running smoothness. For use in Classic interior panel.

Dust filter

Dust filter (set of 2)

For inner panel Flair or Flair Zero. Washable, durable. Incl. filter rings. Filter class G4.

Dust filter (set of 2)

For Light interior panel. Washable, durable. Filter class G4.

Dust filter (set of 2)

For Classic inner panel. Washable, durable. Filter class G3.

Dust filter (kit for 1 unit)

For fan insert of the ventilation unit iV-Twin+. Washable, durable. Filter class G3.

Dust filter (set of 2)

For filter cartridge aV100 ALD / aV100 ALD. Washable, durable. Filter class G1.

Dust filter Aventus (1)

For ventilation unit Aventus. Disposable filter. Filter class G2.

Pollen filter

Pollen filter (set of 2)

For inner panel Flair or Flair Zero. For use during pollen flight times. Disposable filter. Incl. filter rings. Filter class F5.

Pollen filter (set of 2)

For Classic inner panel. For use during pollen flight times. Disposable filter. Filter class F5.

Pollen filter (kit for 1 unit)

For fan insert of the ventilation unit iV-Twin+. For use during pollen flight times. Disposable filter, filter class F5.

Pollen filter (set of 2)

For filter cartridge aV100 ALD / aV100 ALD. For use during pollen flight times. Disposable filter, filter class G3.

inVENTer accessories

Activated carbon filter

Activated carbon filter (set of 2)

For inner panel Flair or Flair Zero. Disposable filter. Incl. filter rings.

Activated carbon filter (set of 2)

For Classic inner panel. Disposable filter.

Activated carbon filter (kit for 1 unit)

For fan insert of the ventilation unit iV-Twin+. Disposable filter.

Flimmer Filter

Flimmer Filter

For filter element for aV100 ALD / aV100 ALD Plus. Three-dimensional high-performance filter with insert Ø 94 mm, length 101 mm. Durable disposable filter, filter class F7.

Windbreak

Windbreak insert R-D160 Disposable filter, filter class F5.

For installation in wall mounting sleeve iV-Smart+, iV14-Zero or iV-Light. Additional protection against strong wind.

Windbreak insert R-D100

For installation in wall mounting sleeve aV100 Additional protection against strong wind.

Sockets for controllers

Socket for wall mounting 70 x 87

For sMove s4 and s8 controllers, Ø 70 mm, depth 87 mm.

Flush-mounted socket 60 x 90

For sMove s4 controller, Ø 60 mm, depth 90 mm.

Flush-mounted socket 60 x 66

For sMove s4, s8, and MZ-Home controllers, Ø 60 mm, depth 66 mm.

Dry wall socket socket 68 x 61

For sMove s4, s8, and MZ-Home controllers, Ø 68 mm, depth 61 mm.

inVENTer accessories

Sensors



Hygrostat HYG12

External room hygrometer for automatic regulation of humidity. Extension of the basic controllers sMove s4 and sMove s8 / in connection with the exhaust fans Aventus and Avio N 100. Adjustment of the limit value by means of a setpoint wheel.
Sensor housing 81 x 81 x 28 mm (W x H x D). Surface mounting.



Hygrostat HYG18

External room hygrometer for automatic regulation of humidity. Digital display to show the relative room humidity and temperature. Extension of the basic controllers sMove s4 and sMove s8 / in connection with the exhaust fans Aventus and Avio N 100. Setting of the limit value and the switching hysteresis by means of the rotary knob.
Sensor housing 81 x 81 x 29 mm (W x H x D). Surface mounting.



CO₂ Sensor CS1

Room sensor for background monitoring of carbon dioxide values for extended assurance of indoor air quality. Extension of the basic controllers sMove s4 and sMove s8 /

Extension of the automatic control function of the controller MZ-Home within a ventilation zone (connection to the corresponding Clust-Air-Module®).

Measured parameter: Carbon dioxide (CO₂)

Measuring range: 0 – 2000 ppm

NDIR sensor measurement method

Sensor housing 84.5 x 84.5 x 25 mm (W x H x D). Surface mounting.

Chimney guard ZP4

A safety device that enables a ventilation system to be operated simultaneously with a room air-dependent fireplace. Extension for inVENTer controllers. With temperature sensor and smoke tube adapter.

Measured parameter: Differential pressure

Measurement method: Differential pressure determination from 45 °C (furnace heated)

Sensor housing ZP4 UP 160 x 160 x 70 mm (W x H x D) (flush-mounted version)

Sensor housing ZP4 Plus UP 180 x 180 x 65 mm (W x H x D) (flush-mounted version with touch display)

Sensor housing ZP4165 x 165 x 70 mm (W x H x D) (dry wall version)

Front panel 180 x 180 mm

Warranty Overview

from 01.01.2016 onwards

inVENTer's manufacturer warranties

The inVENTer's manufacturer warranties cover premature product wear for the following products for the specified period:

Manufacturer's warranty 5 years

- Reverse fans and fans
- Exhaust fans and Aventus fan insert
- Electronic components (controllers, sensors, electronic accessories)
- Wall mounting sleeves iV/aV ventilation systems
- PAX main module

Manufacturer's warranty 30 years

- Ceramic unit of heat accumulators

The following warranty conditions apply:

The warranty only covers demonstrable material or manufacturing defects.

- The warranty period commences with the date of purchase.
- The proper installation according to the respective assembly and operating instructions must be carried out by an appropriately qualified specialist company.
- Costs other than the reimbursement of defective components will not be assumed (no assumption of shipping, transport, conversion/disassembly or planning costs).
- Upon registration of the warranty claim, the respective components become the property of inVENTer GmbH.
- If the product in question is no longer manufactured at the time the defect is reported, a similar product with the same basic function can be supplied.
- Once the guarantee has been fulfilled, it is not renewed, nor is it extended.
- The registration of a warranty claim is required within the warranty periods listed above.
- For third-party products, the warranty conditions of the respective manufacturer apply.

Warrantor

inVENTer GmbH, Ortsstraße 4a, 07751 Löberschütz, Germany

Legal warranty 2 years

Of course, the manufacturer's warranty does not limit the statutory warranty. However, this warranty is merely supplementary. The warranty does not affect the warranty for 24 months for all defects that were present at the time of purchase.

Contact person

Our central service department is your contact for the inVENTer manufacturer's warranty or guarantee:

inVENTer GmbH

Abteilung Technischer Service

Ortsstraße 4a

D-07751 Löberschütz

Phone: +49 36427 211-310

Email: service@inventer.de

www.inventer.de/garantie

inVENTer GmbH
Ortsstraße 4a
D-07751 Löberschütz

E-Mail: info@inventer.de
Web: www.inventer.eu



Version: 08/2019
No liability accepted for printing errors.

Ecological Building Systems

For sales and full technical support, please contact Ecological Building Systems or visit www.EcologicalBuildingSystems.com

