



# inVENTer

Installation instructions

## sMove



## Control unit



## Trademarks, copyrights and property rights

inVENTer® is a registered trademark of inVENTer GmbH.

The copyright to this document remains with the manufacturer.  
Rights to all content and images: © inVENTer GmbH 2022.

All trademarks used in this document are the property of their respective manufacturers and are hereby acknowledged.

## Disclaimer

This documentation represents a translation of the original German installation instructions. Information on how to access the installation instructions must be provided to the user (tenant, owner, property management, etc.) after completion of the installation. The content of this documentation has been checked for compliance with the described components. Nevertheless deviations may still occur, therefore no guarantee of compliance can be provided.

This documentation describes the functionality of the standard scope. For reasons of clarity, the documentation does not support to cover all details on all types of the product and cannot cover every conceivable scenario for installation and assembly.

The illustrations in this document may differ slightly from the design of the product that you have purchased. The same functionality is ensured despite any design deviations.

This documentation is updated regularly. Necessary corrections and appropriate supplements are always included in subsequent editions. The latest version can be found at [www.inventer.de/downloads](http://www.inventer.de/downloads).

## Company information

Publisher:

inVENTer GmbH	Phone: +49 (0) 36427 211-0
Ortsstraße 4a	Fax: +49 (0) 36427 211-113
07751 Löberschütz	E-mail: <a href="mailto:info@inventer.de">info@inventer.de</a>
Germany	Web: <a href="http://www.inventer.de">www.inventer.de</a>

CEO: Annett Wettig  
VAT ID number: DE 815494982  
Jena District Court HRB 510380

## Table of contents

<b>1</b>	<b>User and safety instructions .....</b>	<b>4</b>
1.1	User information.....	4
1.2	Safety instructions.....	5
<b>2</b>	<b>System overview: sMove controller .....</b>	<b>7</b>
2.1	Construction.....	8
2.2	Function .....	8
<b>3</b>	<b>Electrical connection .....</b>	<b>10</b>
3.1	Terminal assignments .....	11
3.2	Cabling.....	12
3.3	Jumpers .....	14
<b>4</b>	<b>Preparing for installation.....</b>	<b>15</b>
4.1	Principle sketches: Connection options for ventilation devices.....	15
4.2	Installation dimensions.....	16
<b>5</b>	<b>Installation.....</b>	<b>17</b>
5.1	Routing wires and attaching the mounting box .....	17
5.2	Connecting the switching power supply unit.....	18
5.3	Distributing fan cables.....	19
5.4	Installing the operating unit .....	20
<b>6</b>	<b>Technical data.....</b>	<b>23</b>
<b>7</b>	<b>Scope of supply.....</b>	<b>23</b>
<b>8</b>	<b>Accessories and spare parts.....</b>	<b>24</b>
<b>9</b>	<b>Troubleshooting .....</b>	<b>25</b>
<b>10</b>	<b>Guarantee and warranty .....</b>	<b>26</b>
<b>11</b>	<b>Service.....</b>	<b>26</b>

## 1 User and safety instructions

Thank you for purchasing this high quality product from inVENTer!

This section provides an overview of the basic safety precautions for safe and proper operation of your control unit.

### 1.1 User information

#### Safety and warning instructions

The safety and warning instructions in these installation instructions have a uniform structure and are marked with a symbol on the left side of the instruction. A signal word in front of the text also indicates the hazard level. If several hazard levels exist, the highest level safety instruction is always used.

The safety and warning instructions contain the following information:



**SIGNAL WORD: Type and origin of the danger.** Possible consequences of the danger! Measures to avoid the danger.

The signal word indicates the severity of the potential danger unless the preventive measures are taken:



**DANGER** means: Imminent danger of serious injury or death.



**WARNING** means: Possible danger of serious injury or death.



**CAUTION** means: Direct danger of minor/significant injury.



**NOTICE** Means: Direct or possible risk of property damage due to an adverse event/state.

If you see these signs, ensure you observe the described measures to prevent possible hazards and/or damage.

#### Other symbols used in this documentation

In addition to the safety instructions, the following symbols are used:



This symbol indicates practical and useful tips for handling your ventilation system.



Before each step, any additional tools and materials required for the activity are listed.



The graphics in Section 6: Installation show the interior wall.

- ▶ **Action required:** This prompts the user to perform a specific action.
- ⇒ **Check the results:** This requires you to check the results of the action you have performed.
- 👁️ **Action focus:** To be taken into account in the corresponding assembly step.

## 1.2 Safety instructions

The installation instructions are part of your sMove control and must be available at all times (see [www.inventer.de/downloads](http://www.inventer.de/downloads)). When handing the system to a third party, the information regarding access to the installation instructions must be handed over also.

Before performing any work on the equipment/system, read the installation instructions carefully and observe all notices that refer to the installation process in this section. Also note the safety instructions that precede the described handling instructions. Non-observance of safety instructions could result in injury and/or property damage.

#### Intended use



The sMove control unit (also referred to in the further text as "controller" or "sMove controller") must only be used to control decentralised iV ventilation devices with heat recovery (iV-Smart+, iV14-Zero, iV-Light, iV-Compact [Xenion fan in each case], iV14-MaxAir, iV-Office product series [Xenion EFP fan in each case] and the iV-Twin+ product series [Mini-Xenion fan]) from inVENTer GmbH.

Specifically, the following must be used:

- The sMove controller for controlling the inVENTer ventilation devices with heat recovery integrated into the system.
- The sensor technology paired with the controller (HYG18 humidistat, HYG12 humidistat, CS1 CO2 sensor or pressure monitor) for the delivery of temperature, humidity and CO2 values to the sMove controller, which in turn uses these values to control the inVENTer ventilation devices with heat recovery.

#### Requirements for intended use

- Always observe the relevant standards, regulations and guidelines when installing the equipment / system. In particular also applicable building regulations, fire safety regulations and accident prevention regulations of the employers' liability insurance association.
- Use the devices integrated into the ventilation system only in accordance with the applications that are described in this documentation and only in conjunction with the components that are recommended, approved and named by inVENTer GmbH in this documentation. Changes or modifications to the devices are not permitted.
- Before starting work, you should have a project plan showing the number of ventilation devices, the location of the ventilation devices, the ventilation principle (cross ventilation, single room ventilation, extract ventilation) and the associated controllers. The exact positioning of the individual devices and control units must be checked at the installation site and, if necessary, adapted to the local conditions with the involvement of the responsible planner or user.
- Your ventilation system is exclusively designed for use in ambient temperatures between -20 and 50°C.
- Trouble-free and safe operation of the equipment/system depends upon proper transportation, proper storage and installation as well as careful operation and maintenance.
- These installation instructions are only valid in conjunction with the installation and operating instructions of the corresponding ventilation device with heat recovery and supplement these. All legal notices that are listed in the respective installation instructions also apply without restriction to this document.

-  • **DANGER:**  
**The unit may only be installed by a qualified electrician.**
  - When laying the power cable, observe the requirements of protection class II.
  - Connect all devices of a ventilation system to the same circuit breaker.
  - Route and connect cables only while in a voltage-free state!
  - The mains supply must correspond to the specifications on the type plate.
  - Before working on electrical installations, disconnect all affected units from the power supply.
  - Check before making any drill holes whether there are wires in the drilling area.
-  • **WARNING:** For joint operation of a ventilation device with fireplaces, safety measures must be taken to prevent a negative pressure from developing in the building. The responsible chimney sweep and/or building planner decides which measures need to be carried out.
-  • **NOTICE:** Ensure adequate contact between the wires when connecting the sMove controller.
- **NOTICE:** Laying cables whose sheathing is not resistant to plastering under plaster leads to short circuits and cable fire! Lay cables without a plaster-resistant cable sheath in the conduit.
- **NOTICE:** The use of too small a cable cross-section leads to too great a voltage drop and/or contact is not guaranteed!  
 Use wire ferrules with collars to connect braided wires.
- **NOTICE:** The unit has scratch-sensitive plastic surfaces. Do not touch the components with oily and/or dirty hands. Avoid contact with sharp or pointed objects, e.g. rings.
- When using several ventilation devices controlled by several controllers, you must ensure that the ventilation devices are synchronised with each other.

Any kind of use other than the intended use will exclude all liability claims.

### Improper use

The sMove controller is intended exclusively for the control of the ventilation devices specified in the section on intended use. Any other use is strictly prohibited.

### Qualified personnel

The equipment/system may only be set up, operated and cleaned in conjunction with this documentation and the documentation for the controllers.

Installation, electrical connection and commissioning of the equipment/system may only be performed by qualified personnel. Qualified personnel within the meaning of the safety notices in this documentation are persons who are authorised to install, put it into operation and identify equipment, systems and circuits in accordance with established safety procedures.

### Conformity

The ventilation device complies with the technical safety requirements and standards of electrical appliances for domestic use. It conforms to current European Union and United Kingdom directives. The full text of the EU declaration of conformity is available at the following Internet address: <https://www.inventer.de/downloads/>.

## 2 System overview: sMove controller

The sMove controller is an electronic control unit for controlling inVENTer® ventilation devices with heat recovery. It is available in the variants s4 or s8, each in two versions (standard or flat).

Each sMove controller can control the following maximum number of ventilation devices:

Ventilation units from the product series	Count sMove 4	Count sMove 8
with Xenion fan	4	8
with Xenion EFP/Mini-Xenion fan	2	4

It features a visually discreet, timeless and flat design as well as easy installation. The controller is operated by touching the capacitive button and the slide control on the control panel. Integrated indicator lights mean that the control panel acts simultaneously as a visual feedback / display for the user.

The sMove controller can be used either as a base control unit or with additional sensors connected.

When used as a base control unit, there is a choice of operating modes for the ventilation device and the air flow can be set steplessly or at 4 predefined levels.

An external interface allows the scope of functions to be expanded:

- Demand-based ventilation via sensor technology (humidistat, CO2 sensor, VOC sensor<sup>1)</sup> [NO]), or
- Integration of a safety device (e.g. pressure monitor, [NC]) with simultaneous operation of the ventilation devices with fireplaces.
- Integration of the sMove controller into an existing building management system via an analogue input

### Components

- Mounting plate
- Operating unit
- Switching power supply unit<sup>2)</sup>
- Mounting box (optional)

### Versions

The sMove controller is available in standard and flat versions. In both versions, the external interface can be configured either as an external switching contact or as an analogue input.

**Flat version:** The controller switches off the ventilation device for 1 hour when in "Off" mode. The ventilation device then continues to operate using the previously saved operating mode and ventilation level. The use of the Flat version is recommended in areas where it is desirable not to turn off the ventilation system in order to protect against moisture build-up.

**Standard version:** The sMove controller switches the ventilation device off completely when in "Off" mode. For the ventilation device to work again, a ventilation level must be selected.

<sup>1)</sup> VOC = volatile organic compounds

<sup>2)</sup> optionally as a flush-mounted or DIN rail switching power supply unit

## 2.1 Construction

The sMove controller consists of a mounting plate for installation on the interior wall and a control unit. The control unit contains the controller electronics and the control panel (acrylic glass cover). A switching power supply unit (flush-mounted or control cabinet mounting) for power supply is also included in the scope of delivery of the sMove controller.

The control panel on the surface of the control unit serves as the operating and display surface.

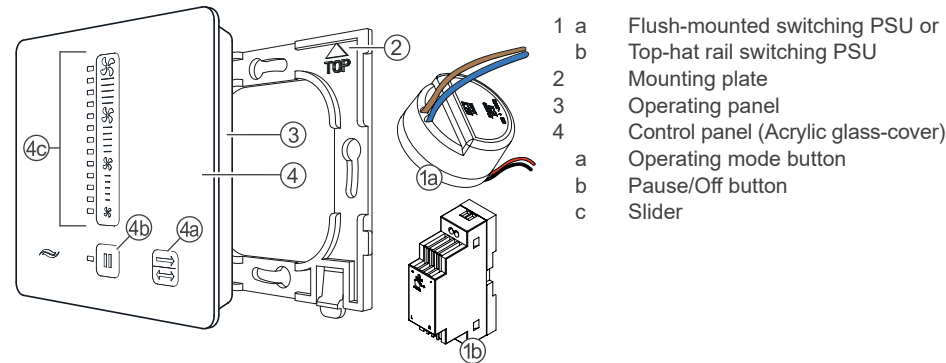

Figure 1: Front view of sMove controller

## 2.2 Function

The sMove controller is a control unit for decentralised ventilation devices with heat recovery from inVENTer GmbH. Where these are connected, the information determined at the controller via the sensor technology is incorporated into the control of the ventilation device.

### sMove controller without connected external interface

If no sensor is connected and the controller is not integrated into the home control system, the operating mode and the intensity of the air volume flow can be set on the sMove controller.

The heat recovery and ventilation modes can easily be set by repeatedly touching the Mode button. The operating modes Pause (optionally 1h, 2h, 4h or 8h) and OFF are switched on or off by repeatedly pressing the Pause/Off button.

The ventilation device can also be switched off completely by holding down the Pause/Off button (standard version only). The boost function can be selected by holding down the top fan symbol on the slider.

There are four preset ventilation levels (fan symbols on the slider) for the ventilation devices which define the rotational speed of the fans and therefore the units' air flow. These are fixed and cannot be changed:

- Level 1 – 25 %
- Level 2 – 35 %
- Level 3 – 50 %
- LED10 - 70 %
- Level 4 – 100 %

The air volume flow can also be changed continuously by means of the slider.

### sMove controller with connected external interface

The external interface is a bi-functional port on the back of the operating unit. It enables  
 A: the connection of a sensor with potential-free switching contact (NO/ NC contact), or  
 B: Use as an analogue input for the integration of the ventilation system into an existing building management system.

#### A: Interface configured as external switching contact (sensor system)

If sensors are connected to the sMove controller, the range of the controller's functions increases and this also allows demand-based ventilation alongside manual ventilation, or the integration of a safety device.

All functions of the controller without connected sensors are available (manual control).

The sensor used must have a potential-free relay contact as its output.

The function settings of the interface are adjusted via the jumper on the back of the operating unit.

Sensor	Switch	Limit value exceeded	Limit value not reached
CO <sub>2</sub> sensor	Make contact (NO)	Switch all ventilation devices connected to the controller to ventilation mode, ventilation level 3 (50 %).	Switch all ventilation devices connected to the controller to the originally set operating mode and ventilation level.
VOC sensor			
Humidistat			
Pressure sensor (4 Pa)	Break contact (NC)	Switch all ventilation devices connected to the controller to OFF mode.	

#### • Connection of an external normally open contact, (NO):

If the pre-defined limit (cannot be changed on the controller) is exceeded, the sensor relays this to the controller. This then switches all connected ventilation devices to ventilation mode with a pre-defined air flow of 50%.

The function remains active until the corresponding parameter falls below the pre-set limit again. Then all ventilation devices connected to the controller switch to the originally set operating mode and ventilation level.

#### • Connection of a safety device, (NC):

The external interface is used to integrate safety devices, e.g. a 4 Pa pressure sensor, into the ventilation system while simultaneously operating the ventilation system with fireplaces.

If this interface is used in conjunction with an external pressure sensor (4 Pa pressure sensor), the air pressure indoors is continuously monitored. As soon as this exceeds the safety-relevant limit, the sensor transmits this to the controller. This then switches all connected ventilation devices off. The function remains active until the air pressure drops below the safety-relevant limit again. Then all ventilation devices connected to the controller switch to the originally set operating mode and ventilation level.

### sMove controller with connected external interface

#### B: Interface configured as analogue input (building control system)

If the interface is used as an analogue input, the ventilation device can be integrated into an existing building management system. To do so, a predefined DC voltage level is set in the home automation control unit, depending on the desired function.

Depending on the control voltage, the ventilation and heat recovery modes are available in ventilation stages 1 - 4, as well as switching off the connected ventilation devices. (for control voltages, see section 3.3: Electrical connections – jumpers).

## 3 Electrical connection



### DANGER

#### Exposed electrical components.

Electric shock and injury due to live components (230V, 50Hz)!

- Before working on electrical installations, disconnect all affected equipment from the power supply.
- Observe the requirements for protection class II when laying the power supply cable. Do not lay live cables.
- Lay the mains connecting cables and signal cables separately.
- Guide the system components of the ventilation system to the same automatic safety device.

**Installation and connection must only be performed by qualified and trained personnel.**



### NOTICE

#### Insufficient cable cross-section.

Excessive voltage drop and/or contact cannot be guaranteed!

Only use the following cable cross-sections:

- Power cable: 1.5 mm<sup>2</sup>
- Fan BUS: min. 0.75 mm<sup>2</sup> – max. 33 m length with star-shaped connection of the fans
- Operating voltage cable: 0.75 – 1.0 mm<sup>2</sup>



The terminals on the back of the control unit are finger-operated, spring-loaded terminals. The terminals have a connection capacity of 0.1 to 1.0 mm<sup>2</sup>. They are suitable for solid and braided wires.

The use of wire ferrules is not necessary. If wire ferrules are used, they must increase the cross-section. Their material thickness is not included.

## 3.1 Terminal assignments

Connector	Terminal	Meaning	Colour	
Switching power supply unit				
Power cable/ Input cable for switching power supply unit	AC/L	Phase	Brown	
	AC/N	Neutral conductor	Blue	
Controller operating voltage Output cable for switching power supply unit	+ 24 V	Controller operating voltage	Red	
	GND (⊥)		Black	
Rear view of sMove controller operating unit				
Connecting terminal, 5-pole, spring-loaded terminal	Controller operating voltage	GND (⊥)	Controller operating voltage	Black
		+ 24 V		Red
	Fan BUS connection	DIR1 (III)	Direction signal 1	White
		VOU+ (IV)	Fan operating voltage	Green
Connecting terminal, 2-pole spring-loaded terminal	External interface (optional)	SC1	Switching contact 1, analogue (+)	–
		SC2	Switching contact 2, analogue (-)	–
Jumpers, each 2-pin (Jumper)	NO	plugged	2	on circuit: Normal operation
				on circuit: Ventilation, level 3
	NC	plugged		on circuit: OFF
				on circuit: Normal operation
–	–	not plugged	1	Only for service settings

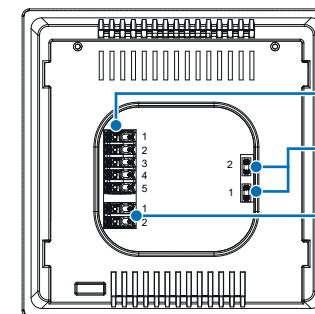

- 1 Connection terminal 8-Pin
- 2 2-Pin plug for jumper (function anment external interface)
- 3 Connection terminal, 2-pole (external interface)
  - potential free switching contact, or
  - analogue control line 0 ... 10 V DC)

### 3.2 Cabling

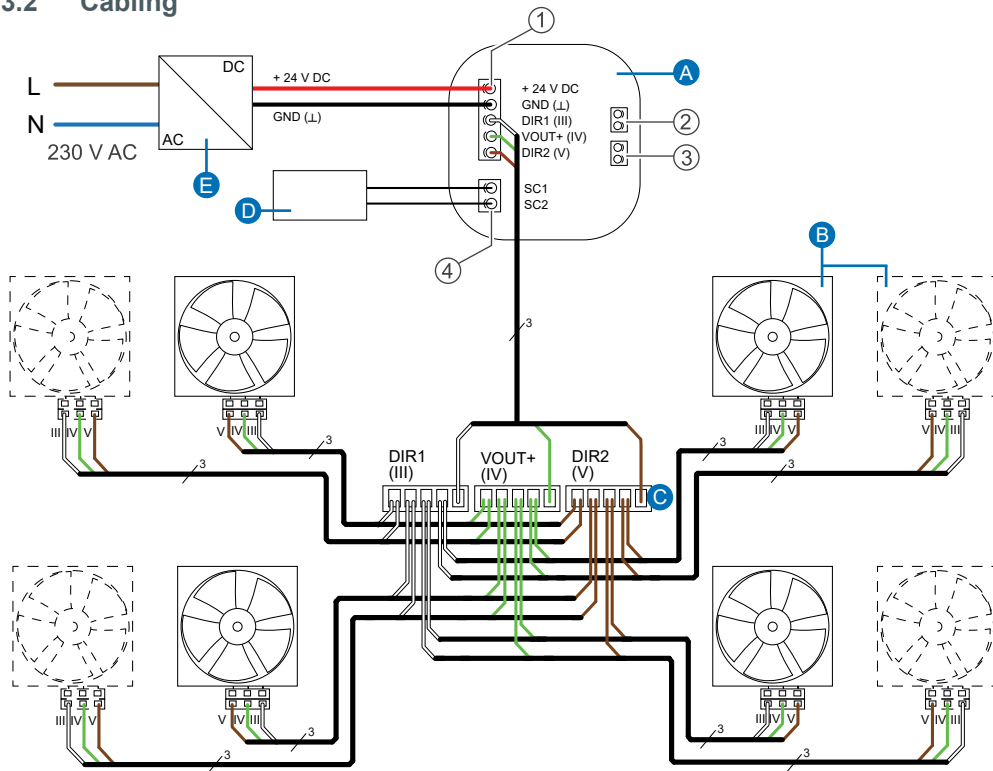

Figure 2: Connection example for sMove controller

#### Components

##### A Rear sMove control unit

- ① Connection terminal, 5-pole (fan BUS)
- ② Jumper, 2 x 2-pin
- ③ Jumper service settings
- ④ Connection terminal, 2-pole (external interface)

##### B Fans

- C Connection terminals, 5-pole (fan BUS distribution)
- D Sensor technology (optional)
- E Switching power supply unit



If the sMove s8 is connected in conjunction with a flush-mounted switched-mode power supply, we recommend distributing the cables between the controller and the fan in a separate mounting box.

#### Maximum cable lengths

Cable	Cross-section/cable type and cabling		Maximum length (controller ... last connected unit)
Operating voltage	2x 1.0 mm; 24 V DC	between switching power supply unit and operating unit	100 m
Fan BUS	LiYY3x0.75; 6 ... 16 V DC		
	Ventilation units with <b>Xenion reversible fan</b>		
		Star-shaped connection	33 m
		Connection in series (2 units)	25 m
		Connection in series (4 units)	15 m
	sMove s8 only	Connection in series (8 units)	10 m
Ventilation units with <b>Xenion-EFP / Mini-Xenion reversible fans</b>			
	Star-shaped connection	25 m	
	Connection in series (2 units)	15 m	
sMove s8 only	Connection in series (4 units)	10 m	



### 3.3 Jumpers

Jumper 2 is used to assign the function of the external interface when a potential-free switching contact is connected (safety device: opener / other sensors: closer) as well as in the case of integration into a house control system.



The position of the jumper may only be changed in a de-energised state.

#### Function assignment depending on the switching contact

		NO (closer)	NC (opener)	Sensor
Position of jumper 2		Function with switch actuation / switching		
	attached	Normal operation	OFF (chimney function)	<b>NO contact:</b> Safety device (4 Pa)
	not attached	Ventilation Ventilation level 3	Normal operation	<b>Closer:</b> Humidistat CO <sub>2</sub> VOC
		Interface as analogue input		

The 2-pin connector for jumper 2 is located on the rear of the operating unit. Jumper 2 is not plugged in at the factory and is located in the accessory bag of the controller. It must be plugged in if required. Jumper 1 is used for service settings and must be left in the delivery state for the controller to function correctly.

If, in the case of an sMove controller being replaced, for example, a pressure sensor (safety device) with normally open contact is connected, it must be configured as normally closed contact (switch with changeover contact) or, if this is not possible, it must be replaced with a (pressure) sensor with normally closed contact.

It is not possible to connect a potential-free switch and an analogue input simultaneously. A connected analogue input always has priority over a potential-free switching contact. If a safety device is integrated, it has priority over other connected sensors.

If jumper 2 is not plugged in and the sMove controller is connected to a home control system, the following DC voltages must be set:

Function	Control voltage [V DC]
Ventilation level 3	$0.00 \leq U \leq 0.25$
Ventilation level 4	$0.75 \leq U \leq 1.25$
Ventilation level 2	$1.75 \leq U \leq 2.25$
Ventilation level 1	$2.75 \leq U \leq 3.25$
OFF	$3.75 \leq U \leq 4.25$
Heat recovery ventilation level 1	$4.75 \leq U \leq 5.25$
Heat recovery ventilation level 2	$5.75 \leq U \leq 6.25$
Heat recovery ventilation level 3	$6.75 \leq U \leq 7.25$
Heat recovery ventilation level 4	$7.75 \leq U \leq 8.25$

## 4 Preparing for installation

- Read the "Installation" and "Electrical connection" sections carefully before installation to avoid installation errors. The installation and connection of the entire ventilation system must be carried out by qualified and trained personnel.
- Before and during installation, note the safety regulations in order to avoid electrical accidents.
- Check the delivery for completeness and transport damage upon receipt using the delivery note. Report missing items immediately.
- Only install all ventilation system devices intended for indoors
  - on finished and flat interior walls.
  - in rooms which are free from aggressive or corrosive gases and extreme dust exposure.
- The sMove controller is installed on the interior wall via a mounting box. Recommended installation height: 1.50 m floor to lintel height (reachability for operation)

### 4.1 Principle sketches: Connection options for ventilation devices

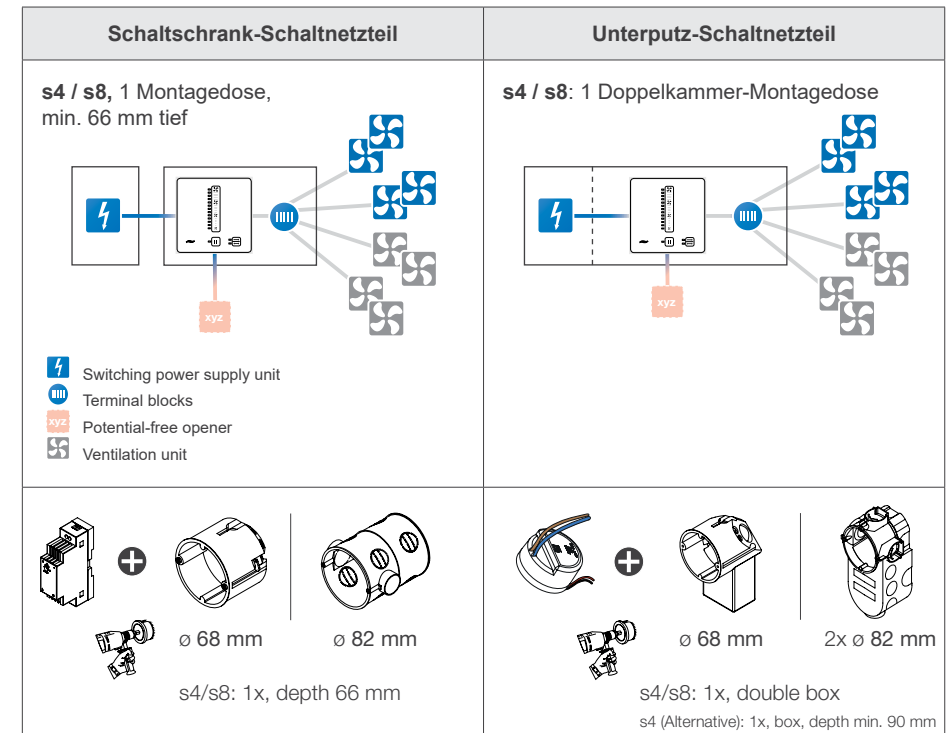



## 4.2 Installation dimensions

Designation	Width [mm]	Height [mm]	Depth [mm]	Ø [mm]
Mounting boxes				
Wall opening for flush-mounted box 60x66	–	–	66	82
Wall opening for flush-mounted plaster-board box 68x61	–	–	61	68
Wall opening for flush-mounted box 60x90 (masonry box 66 mm incl. plaster compensation ring 24 mm)			≥ 95	82
Wall opening for flush-mounted dual-chamber box	–	–	68	2x 82
Wall opening for flexible flush-mounted plasterboard box	–	–	61	68
Switching power supply unit				
s4 control cabinet switching power supply unit	25 (1.5 HP)	93	56	–
s8 control cabinet switching power supply unit	76.5 (4.5 HP)			
Flush-mounted switching power supply unit		33		54

Table 1: Installation accessories and installation dimensions

## 5 Installation



### DANGER

#### Exposed electrical components.

Electric shock and injury due to live components (230V, 50Hz)!

- **Installation and connection must only be performed by qualified and trained personnel.**

### 5.1 Routing wires and attaching the mounting box

#### Requirements:

- The milled holes for the mounting box(es) on the interior wall are created.
- Route the wires needed to connect the controller to the installation site:
  - **Power cable** between control cabinet and installation site:  
Flush-mounted switching power supply unit: AC 230 V, 50 Hz  
Control cabinet switching power supply unit: DC 24 V
  - **Fan BUS**, 3-wire, route between ventilation device wall opening and controller installation site.
  - Optional when sensor connected:  
Power cable to the installation site of the external sensor  
Signal cable, 2-wire, between the controller installation site and installation site of the external sensor
- Lay the cables at the mounting location of the controller and at the mounting location of the junction box in the respective mounting box.
- Install the mounting box on the interior wall.

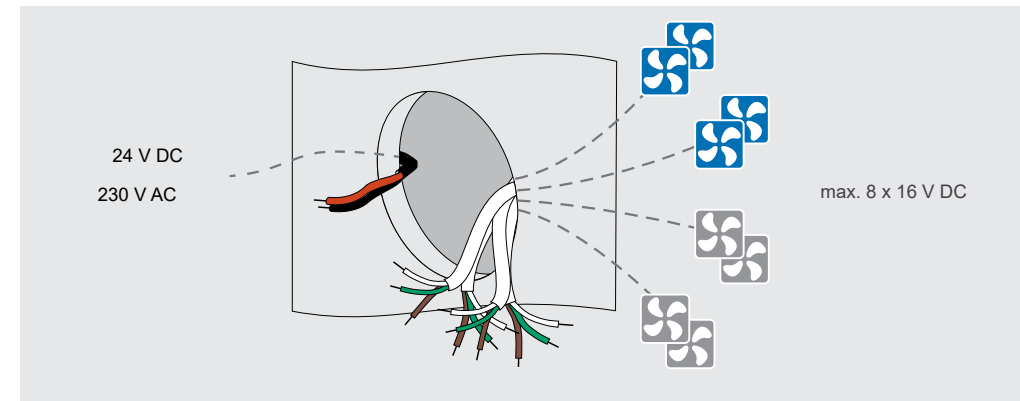

## 5.2 Connecting the switching power supply unit



Flush-mounted switching power supply unit: Terminal blocks, 2-pole

### Requirements:

- The cables are routed to the installation site.
- The mounting box is attached.

### Control cabinet switching power supply unit

- ▶ Secure the switching power supply unit to the control cabinet's DIN rail.
  - sMove s4: It requires 1.5 HP of space.
  - sMove s8: It requires 4.5 HP of space.

- ▶ Connect the switching power supply unit:

- Attach the phase conductor to terminal L
- Attach the neutral conductor to terminal N
- Attach the (red) wire to the (+) terminal.
- Attach the (blue) wire to the (-) terminal.

⇒ The control cabinet switching power supply unit is connected.

### Flush-mounted switching power supply unit

The flush-mounted switching power supply unit is placed in the lower area of the double-chamber mounting box.

- ▶ Connect the **power supply unit input wires** (blue/ brown) using the terminal blocks:

- Connect the phase conductor (brown) to wire L.
- Connect the neutral conductor (blue) to wire N.

- ▶ Place the power supply unit in the lower cavity area of the mounting box.

👁️! The switching power supply unit output wires extend into the interior.

⇒ The flush-mounted switching PSU is connected.

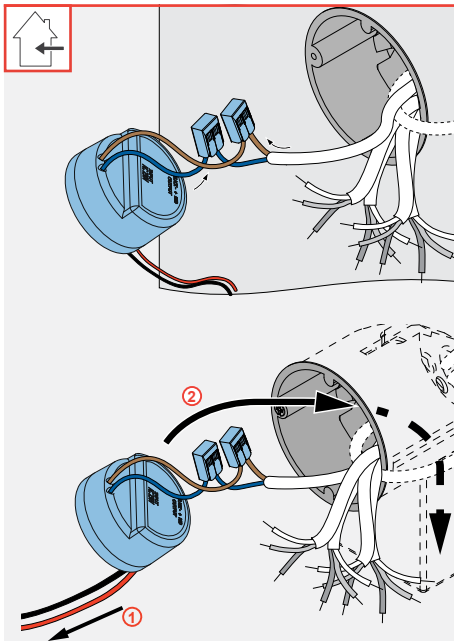
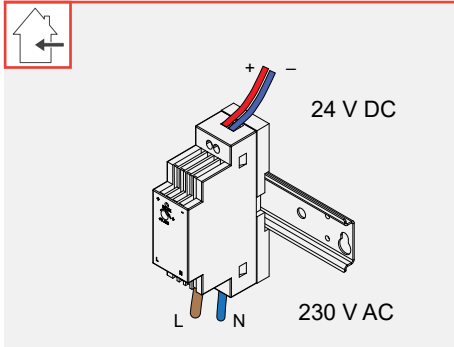

## 5.3 Distributing fan cables

We recommend the star-shaped connection of fans to the sMove controller. The distribution of wires to the fan in this case takes place within the prepared mounting box using 5-pole connection terminals. Alternatively, the fans can be connected in sequence. In this case, no distribution takes place. The fan BUS is attached directly to the terminal on the operating unit. Note the connection capacity of the screw terminal of no more than 1.5 mm<sup>2</sup>.



Stripping tool, crimping tool, fan BUS connecting cable, 3-wire, terminal blocks (5-pole (3x), included scope of supply)

### Requirements:

- The switching power supply unit is attached.

- ▶ Connect the fan BUS cables to a terminal block, 5-pole, as follows:

The wire ends

- of the same colour
- ventilation devices operated in pairs attach together with one pole of a terminal block

⇒ A maximum of 4 poles are occupied with 1 wire each.

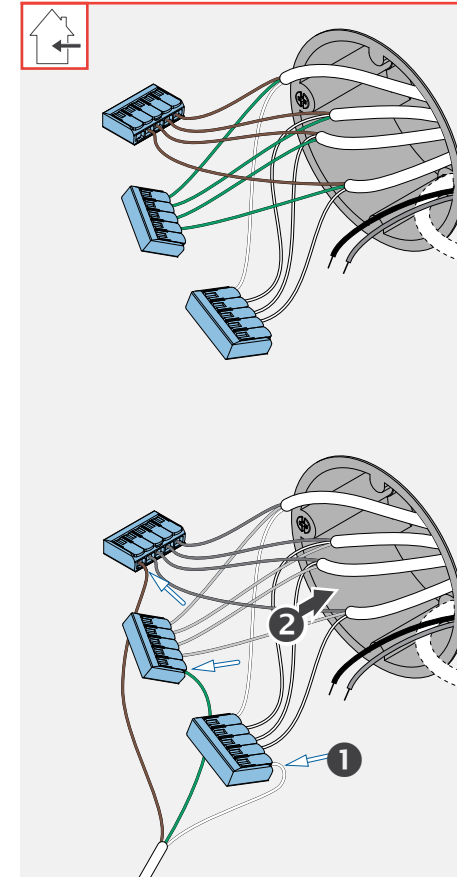

- ▶ Attach the wire ends of the additional connecting cable, 3-wire, to the terminal block of the corresponding colour (1).

- ▶ Place the connected terminal blocks in the mounting box (2).

⇒ The connecting cable extends out of the mounting box.

⇒ The fan cables are distributed.

### 5.4 Installing the operating unit

The control unit is mounted on the prepared controller mounting box. The fan cables are in the box and are already distributed in it. Depending on the installation scenario, the switching power supply is located in the control cabinet or in the lower area of the mounting box.

*To connect an optional sensor, e.g. CO<sub>2</sub> sensor or to a home automation system, follow the instructions in grey italics.*



Stripping tool; crimping pliers; screwdriver

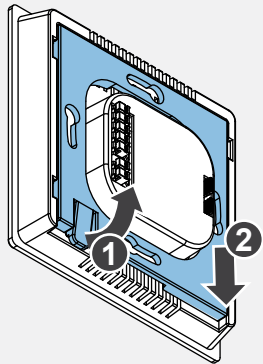

**Requirements:**

- The switching power supply unit is attached.
- The fan wires are distributed.

- ▶ Pull the lever on the lower right side of the operating unit backwards (1).
- ▶ Slide the base plate downwards as far as the stop (2).

⇒ The operating unit is unlocked.

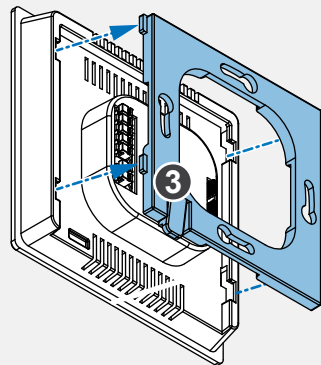

- ▶ Remove the base plate from the operating unit (3).

⇒ The base plate has been removed from the operating unit.

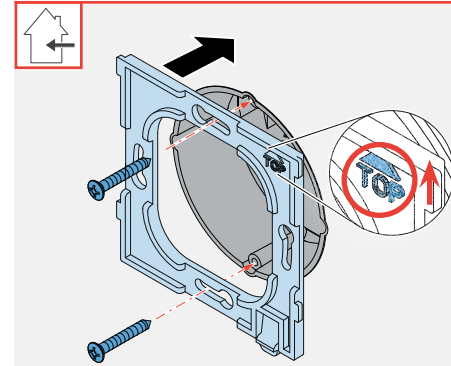

- ▶ Screw the operating unit base plate to the box using fixing screws.

👁️ **!** The arrow above the lettering TOP is pointing upwards.

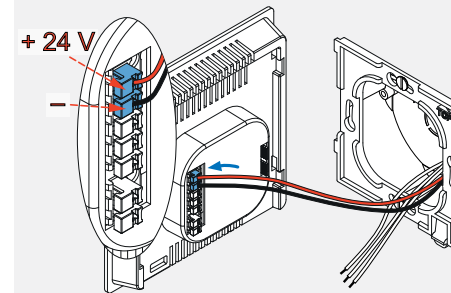

**!** **NOTICE:** If the terminals are connected incorrectly, the sMove controller or connected components will not work!

- Ensure the correct terminal assignment when connecting the cables.

- ▶ Attach the cables to the back of the operating unit:

- **Operating voltage cable**, 2-core, in the two upper poles of the 5-pole connection terminal:
  - Red wire (+) to the first connecting pole
  - Black wire (L) to the second connecting pole;
- **Fan BUS**, 3-wire, in the three lower poles of the connection terminal;
  - DIR1 (III) in the third connection pole
  - VOUT+(IV) in the fourth connection pole
  - DIR2 (V) in the fifth (lower) connection pole;
- Optional: **Sensor cable**, 2-wire, to the 2-pole connection terminal.

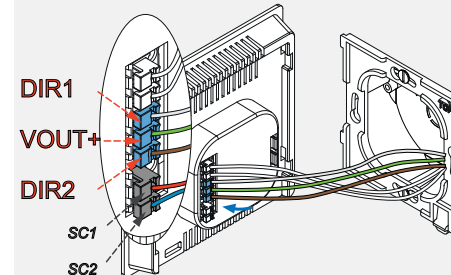

Terminal	Meaning	Colour
+ 24 V	Supply voltage 24 V DC	Red
L	GND	Black
DIR1	Direction signal 1	White
VOUT+	Fan operating voltage	Green
DIR2	Direction signal 2	Brown
SC1 (+)	External interface	
SC2 (-)	(optional sensor)	



**NOTICE: If the jumper on the circuit board is set incorrectly, the controller will not have the desired function!**

- Note the position of the jumper.

- ▶ Plug in jumper 2 (above, in the accessory bag) so that the desired function is activated (see Electrical connection - jumpers).

Interface	Jumper 2	Function during switching
Pressure sensor (opener <sup>1)</sup> )	closed (plugged in)	OFF
Other sensors (closer)	open (not plugged in)	Ventilation level 3
Analogue	open (not plugged in)	Integration into building control system



<sup>1)</sup> For retrofitting, observe the information on the pressure sensor, page 14 - Jumper position.

- ▶ Turn the operating unit around.
  - ⇒ The cables are directed towards the mounting box.
- ▶ Mount the operating unit behind the guides on the base plate.
  - 👁️! The ventilation slots are directed upwards and downwards.
  - 👁️! The positions of the receptacle for the control unit lock and the lever on the base plate match.

- ▶ Slide the operating unit downwards as far as the stop.
  - ⇒ The operating unit should snap audibly into place.

⇒ You have installed the sMove controller.

## 6 Technical data

Feature	Value
Protection class (DIN EN 61140) / Type of protection (DIN EN 60529)	IP20 / II
Switching power supply unit input voltage / mains voltage [V AC] [Hz]	220 ... 240 / 50 ... 60
Switching power supply unit output voltage / Controller operating voltage [V DC]	24
Power consumption in standby [W]	2.5
Max. power consumption [W]	18
Output voltage fan BUS [V DC]	6 ... 16
External switching contact (optional)	
Safety device	Potential-free break contact
Other sensor technology	Potential-free make contact
Operating temperature [°C]	5 ... 50
Electrical protection area (in accordance with VDE 0100)	Outside protection areas 0 ... 2
Conformity	 

## 7 Scope of supply

### Standard components

All standard components are also available as spare parts. Contact your local distributor to order accessories for your controller.

Component	Item number
sMove s4 controller - Standard or Flat, each incl. switching power supply unit	1001-2006
sMove s8 controller - Standard or Flat, each incl. switching power supply unit	1001-2007

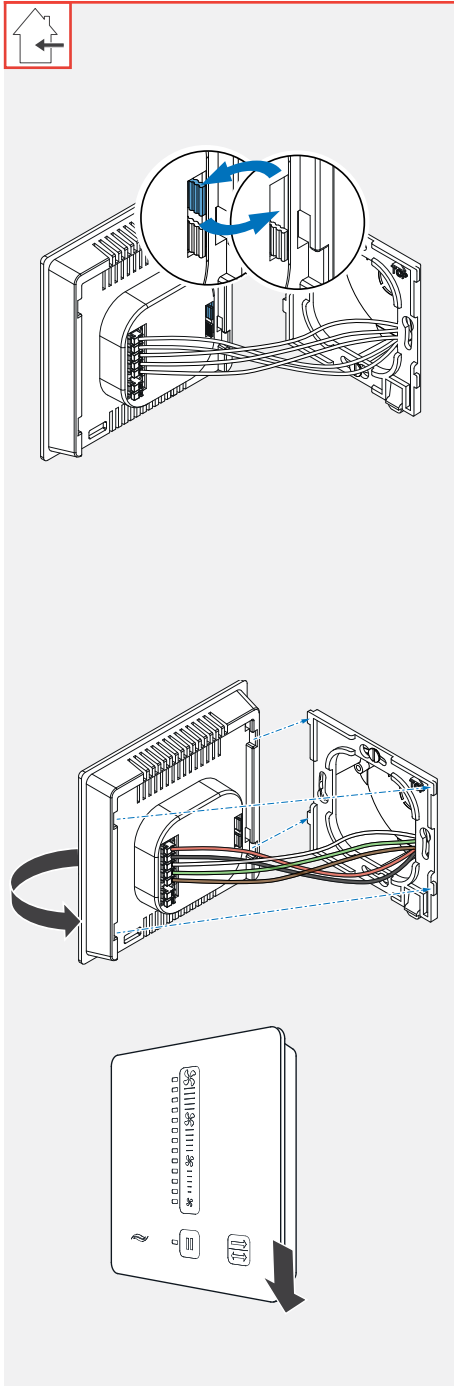

## 8 Accessories and spare parts

Contact your local distributor to order accessories for your ventilation system.

Component	Item number
<b>Operating unit</b>	
sMove operating unit	3002-0396
<b>Sensor technology (optional)</b>	
CO <sub>2</sub> sensor CS1	1004-0145
HYG12 humidistat	1002-0015
HYG18 humidistat	1002-0044
<b>Switching power supply units</b>	
Switching power supply unit Nt17-s4 (for DIN rail installation)	3002-0274
Switching power supply unit Nt17-s8 (for DIN rail installation)	3002-0275
Flush-mounted PSU NT18-s4	3002-0318
Flush-mounted power supply unit NT17-Mz/s8	3002-0267
<b>Installation accessories</b>	
Hollow wall box 68x61 (s4/s8 with switching power supply unit)	1003-0084
Hollow wall box 60x66 (s4/s8 with switching power supply unit)	3002-0244
Flexible hollow wall box (s4/s8 with flush-mounted power supply unit)	1003-0150
Dual-chamber flush-mounted box incl. dividing wall (s4/s8 with flush-mounted power supply unit)	1003-0149
Flush-mounted box 60x90 incl. compensating ring (s4 with flush-mounted power supply unit)	1003-0104
Round cable LiYY-O 3x0.75 (33m)	1004-0020

## 9 Troubleshooting

Fault	Possible cause	Remedy
Incorrect function with connected interface	Upper jumper incorrectly/ not attached	Check the upper jumper on the back of the operating unit control: <ul style="list-style-type: none"> <li>attached: OFF for opener (pressure sensor)</li> <li>not plugged in: Ventilation operating mode, level 3 with closer (humidistat, CO<sub>2</sub> sensor)</li> </ul>
Fans not working	Pressure sensor connected as closer (e.g. exchange operating unit)	Conversion of the pressure sensor as a normally closed contact (changeover contact) or, if necessary, replacement with a pressure sensor with a normally closed contact.
Controller not working	Operating unit is incorrectly/ not connected	Check wiring.
	No electrical contact.	Check cables. Ensure cables are stripped sufficiently (approx. 8.5 mm).
Indicator lights do not light up	Faulty controller.	Replace controller.
	There is no power.	Check power supply.
Slide control defective		Replace controller

If you cannot eliminate the fault, please contact our technical customer service. Information as to how, can be found in section 11: Service

## 10 Guarantee and warranty

### Guarantee:

The guarantee refers to the defect-free condition of the product at the time of purchase and covers all defects that were present at the time of purchase. Failure to observe the intended use will invalidate all guarantee claims.

Outside Germany, the national guarantee provisions of the country in which the system is sold apply. Please contact the distributor for your country.

### Warranty:

inVENTer GmbH provides a five-year warranty for electronic components. This covers premature product wear.

### Guarantee and warranty claims:

Further information about the guarantee is available at [www.inventer.de/garantie](http://www.inventer.de/garantie).

In the case of a guarantee or warranty claim, contact your local distributor or factory representative.

In all cases, please return the complete unit to the manufacturer.

The warranty is an additional offering by the manufacturer and in no way affects the applicable law.

## 11 Service

### Complaint:

Check the delivery for completeness and transport damage upon receipt using the delivery note. Report missing items immediately, and at the latest within 14 days to your supplier, distributor or factory representative.

### Accessories and spare parts:

To order components for your ventilation device, contact your dealer or factory representative.

### Technical customer service:

For technical support contact our service staff:



+49 (0) 36427 211-333



service@inventer.de

inVENTer GmbH  
Ortsstraße 4a  
07751 Löberschütz  
Germany  
[www.inventer.eu](http://www.inventer.eu)

Subject to modifications.  
We accept no liability for printing errors.

**Item number: 5021-0029**  
**Version: 1.0 – 10/2022**

